



ELECTRONICS
DESIGN &
MANUFACTURING

Solution Ultima 844/862/880 Installation Manual

ISSUE 1.62





**ELECTRONICS
DESIGN &
MANUFACTURING**

MA48XI

Solution

Ultima

844

/862

/880

Installation

Manual

ISSUE 1.62



(61-2) 9672 1233

*This page has been included for you to cut out and insert into the spine
of the folder*

Solution Ultima 844/862/880

Installation Manual

Copyright © 2001 by Electronics Design and Manufacturing Pty Limited,
SYDNEY, AUSTRALIA

Document Part Number MA48XI

DOCUMENT ISSUE 1.62

Printed 29 October 2001

**This documentation is provided to suit *Solution Ultima 844/862/880* Control Panel
(CC484/CC486/CC488)**

Firmware Revision 1.00 – 1.09

Hardware Revision A - J

Alarm Link required = 2.74 or higher

Control Panel Software Version 1.00 - 1.09 = S844_V10
= S862_V10
= S880_V10

Copyright Notice

All rights reserved. No part of this publication may be reproduced, sent or stored in a retrieval system in any form or by any means, electronic, mechanical, photocopying, recording, or otherwise, without the prior written permission of Electronics Design and Manufacturing Pty Limited.

Trademarks

Throughout this document trademark names may have been used. Rather than put a trademark symbol in every occurrence of a trademark name, we state that we are using the names only in an editorial fashion and to the benefit of the trademark owner with no intention of infringement of the trademark.

Notice of Liability

While every precaution has been taken in the preparation of this document, neither Electronics Design and Manufacturing Pty Limited nor any of its official representatives shall have any liability to any person or entity with respect to any liability, loss or damage caused or alleged to be caused directly or indirectly by the information contained in this book.

Electronics Design and Manufacturing Pty Limited reserves the right to make changes to features and specifications at any time without prior notification in the interest of ongoing product development and improvement.

Table Of Contents

Introduction	17
Introduction	18
Solution Ultima 844 Features	19
Solution Ultima 862 Features	20
Solution Ultima 880 Features	21
Quick Start	22
Solution Ultima 844 Zone Defaults	24
Solution Ultima 862 Zone Defaults	24
Solution Ultima 880 Zone Defaults	24
Zone Types	25
Codepad Indicators	27
CP5 Eight Zone LED Codepad	28
Zone Indicators	28
AWAY Indicator	28
STAY Indicator	29
MAINS Indicator	29
FAULT Indicator	29
Audible Indicators	30
CP5 Eight Zone LCD Codepad	31
Zone Indicators	31
AWAY Indicator	31
STAY Indicator	32
System Disarmed	32
MAINS Indicator	32
FAULT Indicator	33
Programming Mode	33
Off Indicator/Zone Sealed	33
On Indicator/Zone In Alarm	33
Audible Indicators	34
CP5 Master Partitioned LED Codepad	35
Zone Indicators	35
Area On/Off Indicators	35
Area Display Indicators	36
Status Indicators	36
PARTIAL Indicator	36
AUX Indicator	36
MAINS Indicator	37
FAULT Indicator	37
Audible Indicators	37
System Operations	39
System Operations	40
Arming The System In AWAY Mode	40
Forced Arming	40
Disarming The System From AWAY Mode	41
Arming The System In STAY Mode 1	42
Entry Guard Timer For STAY Mode	42
Forced Arming	43
Disarming The System From STAY Mode 1	44
Arming The System In STAY Mode 2	45
Entry Guard Timer For STAY Mode	45
Forced Arming	45
Disarming The System From STAY Mode 2	46

Codepad Duress Alarm	47
Codepad Panic Alarm	47
Codepad Fire Alarm	47
Codepad Medical Alarm	47
Isolating Zones	48
Standard Isolating	49
Code To Isolate	50
Fault Analysis Mode	51
Fault Descriptions	53
System Fault	53
Low Battery	53
Date and Time	53
RF Receiver Fail	53
Horn Speaker	53
Telephone Line Fail	53
E2 Fault	53
Fuse Fail	53
RF Low Battery	53
Tamper Fail	54
Sensor Watch Fault	54
RF Sensor Watch Fault	54
Communication Fail	54
AC Mains Failure	54
Remote Radio Transmitter Operations	55
Remote Radio Transmitter Operations	56
Indications Upon Remote Radio Transmitter Operations	57
Remote Radio User Code Priority Levels	57
Changing Or Deleting Remote Radio User Codes	58
System Functions	61
System Functions	62
Installer Code Functions	62
Adding Or Deleting RF Wireless Devices	63
Set The Number Of Days Until The First Test Report	65
Changing Domestic Phone Numbers	66
Change Telco Arm/Disarm Sequence	68
Setting STAY Mode 2 Zones	71
Satellite Siren Service Mode	72
Turning Telephone Monitor Mode On/Off	73
Walk Test Mode	74
Event Memory Recall Mode	75
Master Code Functions	76
Arm or Disarm Both Areas At The Same Time	76
Changing and Deleting User Codes	77
Changing and Deleting Remote Radio User Codes	79
Changing Domestic Phone Numbers	81
Change Telco Arm/Disarm Sequence	83
Setting STAY Mode 2 Zones	86
Turning Outputs On/Off	87
Setting The Date and Time	89
Walk Test Mode	90
Event Memory Recall Mode	91
User Code Functions	92
Arm or Disarm Both Areas At The Same Time	92
Hold Down Functions	93
Arm The System In AWAY Mode	93
Arm The System In STAY Mode 1	93
Arm The System In STAY Mode 2	94
Horn Speaker Test	94
Bell Test	94

Strobe Test	94
Turning Day Alarm On and Off	95
Fault Analysis Mode	95
Initiate A Modem Call	96
Reset Latching Outputs	96
Codepad Buzzer Tone Change	97
Send Test Report	97
Remote System	99
Operations Via Telephone	99
Remote Arming Via The Telephone	100
Programming	101
Programming	102
Programming With The Remote Codepad	103
Programming With The Hand Held Programmer	105
Programming With The Programming Key	106
Programming Option Bits	107
Installer's Programming Commands	107
Command 958 - Enable/Disable Zone Status Mode	108
Command 959 - Test Programming Key	109
Command 960 - Exit Installer's Programming Mode	110
Command 961 - Reset Control Panel Back To Factory Default Settings	110
Command 962 - Copy Control Panel Memory To Programming Key	111
Command 963 - Copy From Programming Key To Control Panel	112
Command 964 - Erase Programming Key	113
Command 965 - Set Up Domestic Dialling Format	114
Command 966 - Enable/Disable Automatic Stepping Of Locations	115
Command 999 - Display Panel Type Or Software Version Number	117
Disable Factory Default	118
Defaulting The Control Panel	119
Alarm Link Operations	121
Alarm Link Software	122
Remote Connect	122
Remote Connect With Customer Control	122
Remote Connect Without Call Back Verification	123
Remote Connect With Call Back Verification	123
Direct Connect	123
Alarm Link Options	124
Enable Upload/Download Via Alarm Link	124
Enable Alarm Link Call Back	124
Terminate Alarm Link Connection On Alarm	124
Use External Modem Module (CC811) For Alarm Link Operations	124
Domestic Dialling	125
Domestic Dialling Format	126
Domestic Dialling Function	126
Acknowledge Domestic Dialling	126
Setting Up and Programming Domestic Reporting	127
Disable Domestic Dialling	128
Dialler Reporting Formats	129
Transmission Formats	130
Contact ID Format	130
Point ID Codes	131
4+2 Reporting Format	133
Basic Pager Reporting Format	134

Basic Pager Display Information	135
Subscriber ID Number	135
Zone Status	135
System Status	135
Dialler Information	137
Dialler Information	138
Primary Telephone Number For Receiver 1	139
Secondary Telephone Number For Receiver 1	139
Handshake Tone For Receiver 1	140
Transmission Format For Receiver 1	141
Subscriber ID Number For Receiver 1	141
Primary Telephone Number For Receiver 2	142
Secondary Telephone Number For Receiver 2	142
Handshake Tone For Receiver 2	143
Transmission Format For Receiver 2	144
Subscriber ID Number For Receiver 2	144
Dialling Format	145
Reserved	145
Telco Arming Sequence	146
Telco Arming – Call Forward Immediate On	146
Telco Arming – Call Forward No Answer On	146
Telco Disarming Sequence	147
Telco Arming – Call Forward Immediate Off	147
Telco Arming – Call Forward No Answer Off	147
Call Back Telephone Number	147
Ring Count	148
Answering Machine Bypass	148
Telephone Line Fault Options	149
Operate The FAULT Indicator When Telephone Line Fails	149
Sound Speaker, Bell and Strobe When The System Is Armed	149
Sound Speaker, Bell and Strobe When The System Is Disarmed	149
Reserved	149
Ring Burst Time	150
Dialler Options	151
Programming Option Bits	152
Dialler Options 1	153
Dialler Reporting Functions Allowed	153
Disabled = Disable All Dialler Reporting Functions	153
Remote Arming Via The Telephone Allowed	153
Answering Machine Bypass Only When Armed	153
Use Bell 103 For FSK Format (Disabled = CCITT V21 Format)	153
Dialler Options 2	154
Open/Close Reports Only If Previous Alarm	154
Open/Close Reports For STAY Mode 1 and STAY Mode 2	154
Delay Siren Until Transmission Complete	154
Extend Time To Wait For Handshake From 30 - 55 Seconds	154
Dialler Options 3	155
Set DTMF Dialling Pulses To 1 Digit/Second	155
Lockout Telephone Line Fail Alarm	155
Change Decadic Dialling To 60/40	155
External Modem Module (CC811) Required For FSK	155
Alarm Link Options	156
Upload/Download Allowed	156
Call Back Phone Number Required For Upload/Download	156
Exit Upload/Download Connection On Alarm	156
External Modem Module (CC811) Required For Upload/Download	156

Access Codes	158
Installer Code	158
User Codes	159
Solution Ultima 844/862 User Codes	160
Solution Ultima 880 User Codes	160
User Code Priority	161
Arm and Disarm	161
Arm Only	161
Arm and Disarm + Open/Close Reports	161
Arm Only + Closing Reports	161
Arm and Disarm + Code To Isolate	162
Arm and Disarm + Code To Isolate + Open/Close Reports	162
Arm and Disarm + Master Code Functions	162
Arm and Disarm + Master Code Functions + Open/Close Reports	162
Arm and Disarm + Master Code Functions + Code To Isolate	162
Arm and Disarm + Master Code Functions + Code To Isolate + Open/Close Reports	162

Zone Information **163**

Day Alarm Zones	164
Day Alarm Resetting	164
Day Alarm Latching	164
Day Alarm Operation	165
EOL Resistor Value	166
Connections Of Split EOL Resistors Using N/C Contacts	167
Connections Of Split EOL Resistors With Tamper Circuit	167
Connections Of Split EOL Resistors Using N/O Contacts	168

Zone Programming **169**

Zone Operating Information	169
Zone Options	169
Zone Reporting Information	169
Solution Ultima 844 Zones Defaults	170
Solution Ultima 862 Zones Defaults	170
Solution Ultima 880 Zones Defaults	170
Zone Types	171
Instant Zone	171
Handover Zone	171
Delay-1 Zone	171
Delay-2 Zone	171
Reserved	171
Reserved	172
24 Hour Medical	172
24 Hour Panic	172
24 Hour Hold-Up	172
24 Hour Tamper	172
Reserved	172
Keyswitch Zone	172
24 Hour Burglary Zone	172
24 Hour Fire Zone	172
Chime Zone	173
Zone Not Used	173
Zone Pulse Count	173
Zone Pulse Count Handover	173
Zone Pulse Count Time	174
Zone Options 1	175
Lockout Siren & Lockout Dialler	175
Delay Alarm Reporting	175
Silent Alarm	176
Sensor Watch	176
Keyswitch Zone Options	177
Latching Arm and Disarm In AWAY Mode	177
Latching Arm In AWAY Mode	177
Latching Disarm From AWAY Mode, STAY Mode 1 Or STAY Mode 2	177
Latching Arm and Disarm In STAY Mode 1	177

Latching Arm In STAY Mode 1	177
Latching Disarm From STAY Mode 1 Or STAY Mode 2	177
Momentary Arm and Disarm In AWAY Mode	178
Momentary Arm In AWAY Mode	178
Momentary Disarm From AWAY Mode, STAY Mode 1 Or STAY Mode 2	178
Momentary Arm and Disarm In STAY Mode 1	178
Momentary Arm In STAY Mode 1	178
Momentary Disarm From STAY Mode 1 Or STAY Mode 2	178
Zone Options 2	179
Isolate In STAY Mode 1	179
Zone Isolation Allowed	179
Forced Arming Allowed	179
Zone Restore Report	179
Zone Reporting Information	180
Zone Report Code	180
Zone Dialler Options	180
Swinger Shutdown Count For Siren	181
Swinger Shutdown Count For Dialler	182
System Reporting Information	183
Reporting Information	184
Zone Status – Zone Tamper Report	184
Zone Status – Walk Test Report	184
Zone Status – Bypass Reports	185
Zone Status – Trouble Reports	185
Zone Status – Sensor Watch Reports	186
Zone Status – Alarm Restore Code	186
Zone Status Reporting Options	186
RF Supervision Time	187
RF Low Battery Report	187
RF Receiver Trouble Report	188
RF Receiver Trouble Restore Report	188
RF Dialler Options	188
Open/Close Reports	189
Open/Close Reporting Options	189
Codepad Duress Report	190
Codepad Panic Report	190
Codepad Fire Report	191
Codepad Medical Report	191
Codepad Reporting Options	192
System Status – Fuse Fail Report	192
System Status – Fuse Fail Restore Report	192
System Status – AC Fail Report	193
System Status – AC Fail Restore Report	193
System Status - Low Battery Report	194
System Status - Low Battery Restore Report	194
System Status - Access Denied	195
Code Retries	195
System Status Reporting Options	196
Test Reporting Time	197
Test Reporting Dialler Options	197
Programmable Outputs	199
Outputs	200
Output Defaults	200
Default For Strobe	200
Default For Entry/Exit	200
Redirecting Outputs To The Codepad Buzzer	201
Output Event Types	202
Output Polarity	211
Output Not Used	211
Normally Open, Going Low	211
Normally Open, Pulsing Low	211
Normally Open, One Shot Low	211
Normally Open, One Shot Low With Retrigger	211

Normally Open, One Shot Low With Reset	211
Normally Open, One Shot Low With Alarm	212
Normally Open, Latching Low	212
Normally Low, Going Open	212
Normally Low, Pulsing Open	212
Normally Low, One Shot Open	212
Normally Low, One Shot Open With Retrigger	212
Normally Low, One Shot Open With Reset	212
Normally Low, One Shot Open With Alarm	212
Normally Low, Latching Open	212
Timing Of Outputs	213
Pulsing Polarities	213
One Shot Polarities	214

System Event Timers 215

System Event Timers 216

Programming Entry/Exit Timers	216
Entry Timer 1	216
Entry Timer 2	216
Exit Time	217
Entry Guard Timer For STAY Mode	217
Delay Alarm Reporting Time	217
Sensor Watch Time	218
Codepad Lockout Time	218
Siren Run Time	219
Siren Sound Rate	219
Auto Arming Pre-Alert Timer	220
Auto Arming Time	220
Auto Disarming Time	221
Kiss-Off Wait Time	221
Speaker Beep Volume	221
System Time	222
System Date	223
Setting The Date and Time	223

System and Consumer Options 225

Programming Option Bits 226

System Options 1	227
EDM Smart Lockout Allowed	227
Horn Speaker Monitor	227
Strobe Indications For Radio Arm/Disarm	227
Assign Button 4 On Transmitter To Arm STAY Mode 1	227
System Options 2	228
Codepad Panic To Be Silent	228
Codepad Fire To Be Silent	228
Codepad Medical To Be Silent	228
Access Denied To Be Silent	228
System Options 3	229
AC Fail In 1 Hour (Disabled = After 2 Minutes)	229
Ignore AC Fail	229
Zone Pulse Count Handover Allowed	229
Handover Delay To Be Sequential	229
System Options 4	230
Panel To Power Up Disarmed (If Power Reset)	230
Arm/Disarm Tracking On Power Up	230
Internal Crystal To Keep Time	230
Keyswitch Interface, Night Arm Station Or RE005 Installed	230
Consumer Options 1	231
Test Reports Only When Armed	231
Test Report After Siren Reset	231
Auto Arm In STAY Mode 1	231
STAY Indicator To Display Day Alarm Status	231

Consumer Options 2	232
Codepad Display Extinguish After 60 Seconds	232
Single Button Arming Allowed (AWAY Mode, STAY Mode 1 & 2)	232
Single Button Disarming Allowed (STAY Mode 1 & 2)	232
Alarm Memory Reset On Disarm	232
Consumer Options 3	233
Codepad Fault Alarm Beeps Allowed	233
Use Digit 3 For Codepad Duress Instead Of Digit 9	233
Alarms Activate Siren & Strobe In STAY Mode 1 & 2	233
Zone Tamper Alarms To Be Silent	233
Radio Input Options	234
DS304 MHz Receiver (RF3212)	234
Latching Keyswitch Input	234
Momentary Keyswitch Input	234
Partitioning	235
CP5 Master Partitioned LED Codepad	236
Zone Indicators	236
Area On/Off Indicators	237
Area Display Indicators	237
Status Indicators	237
PARTIAL Indicator	237
AUX Indicator	238
MAINS Indicator	238
FAULT Indicator	238
Audible Indicators	239
Operating Codepads In Partitioning	240
Operating From A CP5 Area Addressable LED Codepad	240
Operating From A CP5 Master Partitioned Codepad	240
Programming	241
Partitioning Options 1	241
First To Open/Last To Close Reporting	241
Area 1 Codepad Connected To Data Terminal	241
Reset Sirens From Any Area Allowed	242
Master Codepad To Display AUX Indicator When On-Line	242
Partitioning Options 2	242
Lock Area 1 To Receiver 1 and Lock Area 2 To Receiver 2	242
User Code Allowed To Arm/Disarm Both Areas At Same Time	242
Reserved	242
Reserved	242
Zone Allocations	243
Zone Allocations For Area 1	243
Zone Allocations For Area 2	243
User Code Allocations	245
Setting Up and Programming Codepads For Partitioning	246
Setting Up The Master Partitioned Codepad As The Main Codepad.	246
Setting Up An Area 1 Codepad As The Main Codepad	246
Setting Up An Area 1 Codepad	246
Setting Up An Area 2 Codepad	246
Codepad Connections For Partitioning - Examples	247
RF Information	249
RF Option Bit	250
Sound Siren On RF Receiver Fail	250
Sound Siren On RF Receiver Tamper / Jamming	250
Unseal Zone That Fails Supervision	250
Enable RF Jamming Monitoring	250
RF Device Mapping (Devices 1 – 8)	250
RF Device Mapping (Devices 9 – 16)	250
RF Device Signal Strength (Devices 1 – 8 Read Only)	251
RF Device Signal Strength (Devices 9 – 16 Read Only)	251

<i>Optional Equipment</i> _____	253
Optional Equipment _____	254
<i>Terminals and Descriptions</i> _____	257
Terminal Definitions and Descriptions _____	258
Glossary Of Terms _____	259
Solution Ultima 844/862/880 Wiring Diagram _____	262
Solution Ultima 844/862/880 Component Overlay _____	263
RF3212 Radio Receiver Wiring Diagram _____	264
Telecom Connection Diagrams _____	265
<i>Appendices</i> _____	267
Appendix A _____	268
Telephone Anti-Jamming _____	268
Appendix B _____	269
Test Reports Only When Armed _____	269
<i>Specifications</i> _____	271
Warranty Statement _____	272
Year 2000 Compliance _____	272
Specifications _____	273
Software Version Number _____	273
Advice To Users _____	273
New Zealand Telepermit Notes _____	274
<i>Solution Ultima 844 Programming Sheets</i> _____	275
<i>Solution Ultima 862 Programming Sheets</i> _____	285
<i>Solution Ultima 880 Programming Sheets</i> _____	295
<i>Index</i> _____	305

Introduction

This section includes the following:

- *Introduction*
- *Solution Ultima 844 Features*
- *Solution Ultima 862 Features*
- *Solution Ultima 880 Features*
- *Quick Start*
- *Solution Ultima 844 Zones Defaults*
- *Solution Ultima 862 Zone Defaults*
- *Solution Ultima 880 Zone Defaults*
- *Zone Types*

Introduction

Congratulations on selecting the *Solution Ultima 844/862/880* control panel for your installation. So that you can obtain the most from your unit, we suggest that you take the time to read through this manual and familiarise yourself with the numerous outstanding operating and installation features of this system.

You will notice that in all aspects of planning, engineering, styling, operation, convenience and adaptability, we have sought to anticipate your every possible requirement. Programming simplicity and speed have been some of the major considerations and we believe that our objectives in this area have been more than satisfied.

This installation manual will explain all aspects of programming the *Solution Ultima 844/862/880* control panel from factory default to final commissioning. All system parameters and options are detailed, however, suitability is left up to the individual. Every control panel can be tailored to meet all requirements quickly and easily. The programming simplicity will make your installation quick, accurate and rewarding each and every time.

The *Solution* range of control panels are very popular amongst thousands of people throughout many countries of the world, all who have various levels of technical aptitude and ability. We have tried to aim this installation manual to all levels of readers.

As the *Solution* control panels continue to be improved over the years, they have become very powerful. Some of its early first-time users have advanced to true "power users" and we need to address their needs too, while maintaining the simplicity of the manual and the product.

Solution Ultima 844 Features

The *Solution Ultima 844* security system uses the very latest in microprocessor technology to provide you with more useful features and superior reliability and performance.

Following is a list of the main features that the control panel will provide.

- Eight Programmable User Codes (1 – 8)
- Eight Remote Radio User Codes (9 – 16)
- Four Programmable Hard Wired Or Wireless Burglary Zones
- Four 24 Hour Programmable Hard Wired Or Wireless Zones
- Dual Reporting
- On-Board Line Fault Module
- Telco Arm/Disarm Sequence
- Automatic Arming
- Automatic Disarming
- Codepad Duress, Panic, Fire, Medical, Access Denied Alarms
- STAY Mode and AWAY Mode Operation
- Upload/Download Programmable
- Dynamic Battery Testing
- Entry and Exit Warning Beeper
- Remote Arming
- Answering Machine Bypass
- AC Fail and System Fault Indicators
- Monitored Siren Output
- Strobe Output
- Relay Output
- Separate Fire Alarm Sound
- EDMSAT – Satellite Siren Compatible
- Zone Lockout
- Sensor Watch
- Day Alarm
- Event Memory Recall
- Walk Test Mode
- Delayed Reporting

Solution Ultima 862 Features

The *Solution Ultima 862* security system uses the very latest in microprocessor technology to provide you with more useful features and superior reliability and performance.

Following is a list of the main features that the control panel will provide.

- Eight Programmable User Codes (1 – 8)
- Eight Remote Radio User Codes (9 – 16)
- Six Programmable Hard Wired Or Wireless Burglary Zones
- Two 24 Hour Programmable Hard Wired Or Wireless Zones
- Dual Reporting
- On-Board Line Fault Module
- Telco Arm/Disarm Sequence
- Automatic Arming
- Automatic Disarming
- Codepad Duress, Panic, Fire, Medical, Access Denied Alarms
- STAY Mode and AWAY Mode Operation
- Upload/Download Programmable
- Dynamic Battery Testing
- Entry and Exit Warning Beeper
- Remote Arming
- Answering Machine Bypass
- AC Fail and System Fault Indicators
- Monitored Siren Output
- Strobe Output
- Relay Output
- Separate Fire Alarm Sound
- EDMSAT – Satellite Siren Compatible
- Zone Lockout
- Sensor Watch
- Day Alarm
- Event Memory Recall
- Walk Test Mode
- Delayed Reporting

Solution Ultima 880 Features

The *Solution Ultima 880* security system uses the very latest in microprocessor technology to provide you with more useful features and superior reliability and performance.

Following is a list of the main features that the control panel will provide.

- Eight Programmable User Codes (1 – 8)
- Eight Variable User Codes (Radio Remote/Programmable User Codes (9 - 16))
- Eight Programmable Hard Wired Or Wireless Burglary Zones
- Partitionable To Two Separate Areas
- Dual Reporting
- On-Board Line Fault Module
- Telco Arming/Disarming Sequence
- Automatic Arming
- Automatic Disarming
- Codepad Duress, Panic, Fire, Medical, Access Denied Alarms
- STAY Mode and AWAY Mode Operation
- Upload/Download Programmable
- Dynamic Battery Testing
- Entry and Exit Warning Beeper
- Remote Arming
- Answering Machine Bypass
- AC Fail and System Fault Indicators
- Monitored Siren Output
- Strobe Output
- Relay Output
- Separate Fire Alarm Sound
- EDMSAT – Satellite Siren Compatible
- Zone Lockout
- Sensor Watch
- Day Alarm
- Event Memory Recall
- Walk Test Mode
- Delayed Reporting

Quick Start

The following steps will allow you to use the *Solution Ultima 844/862/880* control panel with the factory default values. The default values allow the control panel to communicate in the Contact ID format. If you are not familiar to programming the *Solution* range of control panels, we suggest that you first read information contained in the programming section beginning on page 102.

1. After all wiring has been completed, connect the AC plug pack to the control panel. Both the MAINS and AWAY indicators will illuminate. The MAINS indicator will display to indicate that the AC mains supply has been connected. The AWAY indicator displays that the system is now armed in the AWAY Mode. If any 24-hour zones are unsealed at the time the system is powered up, the siren, strobe and bell outputs will activate into alarm and the corresponding zone indicator will flash.
2. Enter the default Master Code **2580** followed by the **AWAY** button to disarm the system and to reset any alarm that may have occurred during the system power up. The AWAY indicator will extinguish to indicate that the system has now been disarmed. If any zone indicators are flashing, this would indicate that an alarm had occurred on that zone. If a zone indicator is constantly illuminated, this would indicate that the zone is unsealed.
3. The back-up battery should now be connected.
4. Enter the factory default Installer Code **1234** followed by the **AWAY** button. Two beeps will be heard and the STAY and AWAY indicators will now flash simultaneously to indicate that you have now entered Installer's Programming Mode. When entering Installer's Programming Mode, you will be automatically positioned at "LOCATION 000", the beginning of the Primary Telephone Number For Receiver 1.
5. Enter the Primary Telephone Number followed by the Secondary Telephone Number and the Subscriber ID Number for Receiver 1. Refer to Dialler Information on page 138 for more information.

Remember that when programming a zero in the telephone numbers of Receiver 1 and Receiver 2, a zero must be programmed as a ten. Programming a zero in the telephone number will indicate the end of the dialling sequence. A zero must be programmed as a zero in all locations other than the telephone numbers for Receiver 1, Receiver 2 and the Call Back Telephone number, unless otherwise stated.

6. Set the time for the test reports if required. Any other programming changes required may also be made, otherwise the factory default settings will be used. Refer to Test Reporting Time on page 197 for more information on programming test reports.
7. Enter Installer's Command **960** followed by the **AWAY** button to exit Installer's Programming Mode. Two beeps will be heard and the STAY and AWAY indicators will extinguish. The system has now returned to the disarmed state and is now ready for use. Refer to Installer's Programming Commands on page 107 for more information.
8. Use the Master Code to set the date and time. Refer to How To Set The Date and Time on page 23 for more information.

How To Set The Date and Time

1. Enter your **MASTER CODE** followed by **6** and the **AWAY** button.
Three beeps will be heard and the STAY and AWAY indicators will begin to flash.
2. Enter the day, month, year, hour and minute using the (DD, MM, YY, HH, MM) format (i.e. DD = Day of the month, MM = Month of the year, YY = Current year, HH = Hour of the day, MM = Minute of the day).
Please note that when programming the hour of the day, you will need to use 24:00 hour format.
3. Press the **AWAY** button when finished.
Two beeps will be heard and the STAY and AWAY indicators will extinguish. If a long beep is heard, an error was made when entering the date and time.



$$\begin{aligned} & \boxed{\text{MASTER CODE}} + 6 + \boxed{\text{AWAY}} \\ & + \text{DD} + \text{MM} + \text{YY} + \text{HH} + \text{MM} \\ & \quad + \boxed{\text{AWAY}} \end{aligned}$$
Example

If the date and time needs to be set for the 1st January 1997 at 10:30 PM, program the date and time as follows;



$$\begin{aligned} & 2580 + 6 + \boxed{\text{AWAY}} \\ & + 01 + 01 + 97 + 22 + 30 \\ & \quad + \boxed{\text{AWAY}} \end{aligned}$$

Solution Ultima 844 Zone Defaults

The default zone settings of the control panel are listed in the table below. Zones 1 – 4 may be programmed to any of the available zone types. Zones 5 – 8 are limited to that they may only be programmed to any 24 hour or keyswitch type. Refer to “Table 4: Available Zone Types” on page 25 for the different zone types that may be selected.

<i>Zone No</i>	<i>Zone Type</i>	<i>Zone No</i>	<i>Zone Type</i>
1	Delay-1	5	24 Hour Burglary
2	Handover	6	24 Hour Burglary
3	Handover	7	24 Hour Fire
4	Instant	8	24 Hour Tamper

Table 1: Zone Defaults For Solution Ultima 844

Solution Ultima 862 Zone Defaults

The default zone settings of the control panel are listed in the table below. Zones 1 – 6 may be programmed to any of the available zone types. Zones 7 and 8 are limited to that they may only be programmed to any 24 hour or keyswitch type. Refer to “Table 4: Available Zone Types” on page 25 for the different zone types that may be selected.

<i>Zone No</i>	<i>Zone Type</i>	<i>Zone No</i>	<i>Zone Type</i>
1	Delay-1	5	Instant
2	Handover	6	Instant
3	Handover	7	24 Hour Fire
4	Handover	8	24 Hour Tamper

Table 2: Zone Defaults For Solution Ultima 862

Solution Ultima 880 Zone Defaults

The default zone settings of the control panel are listed in the table below. Zones 1 – 8 may be programmed to any of the available zone types. Refer to “Table 4: Available Zone Types” on page 25 for the different zone types that may be selected.

<i>Zone No</i>	<i>Zone Type</i>	<i>Zone No</i>	<i>Zone Type</i>
1	Delay-1	5	Instant
2	Handover	6	Instant
3	Handover	7	Instant
4	Handover	8	24 Hour Tamper

Table 3: Zone Defaults For Solution Ultima 880

Zone Types

There are thirteen different zone types to choose from when programming zones. These thirteen different zone types are available for all *Solution Ultima 844/862/880* control panels. Refer to Zone Programming on page 169 for more information on programming zones.

<i>Zone Type</i>	<i>Description</i>	<i>Zone Type</i>	<i>Description</i>
0	Instant	8	24 Hour Hold-Up
1	Handover	9	24 Hour Tamper
2	Delay-1	10	Reserved
3	Delay-2	11	Keyswitch
4	Reserved	12	24 Hour Burglary
5	Reserved	13	24 Hour Fire
6	24 Hour Medical	14	Chime Only
7	24 Hour Panic	15	Zone Not Used

Table 4: Available Zone Types

Codepad Indicators

This section includes the following:

- *CP5 Eight Zone LED Codepad*
- *CP5 Eight Zone LCD Codepad*
- *CP5 Master Partitioned LED Codepad*

CP5 Eight Zone LED Codepad

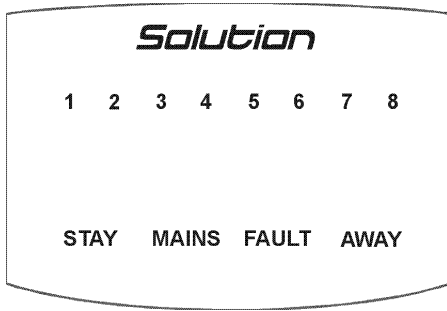

The codepad is the communications interface between you and your alarm system. The codepad allows you to issue commands and offers both visual and audible indications that guide you through the general operation.

The codepad incorporates numerous indicators. There are ZONE indicators that are used to show the condition of each zone and four others for general status. The following is a list of situations and the relevant indications that will be seen.

Figure 1: CP5 Eight Zone LED Codepad (CP508)

Zone Indicators

The ZONE indicators are used to display the status of the zones. The following table lists the various circumstances that the indicators will display (i.e. Zone Sealed, Zone Unsealed).

<i>Indicator</i>	<i>Definition</i>
On	Zone Is Unsealed
Off	Zone Is Sealed
Flashing Fast (0.25 Sec On – 0.25 Sec Off)	Zone Is In Alarm Condition
Flashing Slow (1 Sec On – 1 Sec Off)	Zone Is Manually Isolated

Table 5: Zone Indicators

AWAY Indicator

The AWAY indicator is used to display that the system is armed in AWAY Mode. The AWAY indicator will also flash in unison with the STAY indicator when Installer’s Programming Mode or Master Code Functions are used.

Refer to page 40 for more information on the different methods on arming the system in AWAY Mode.

<i>Indicator</i>	<i>Definition</i>
On	System Is Armed In AWAY Mode
Off	System Is Not Armed In AWAY Mode

Table 6: AWAY Indicator

STAY Indicator

The STAY indicator is used to display that the system is armed in STAY Mode 1 or STAY Mode 2. The STAY indicator will also flash in unison with the AWAY indicator when Installer's Programming Mode or Master Code Functions are used.

For the different methods of arming the system in STAY Mode 1, refer to page 42. Refer to Zone Options 2 on page 179 for information on setting zones to be automatically isolated in STAY Mode 1. For the method of arming the system in STAY Mode 2, refer to page 45. Refer to Setting STAY Mode 2 Zones on page 71 when using the Installer Code or Setting STAY Mode 2 Zones on page 86 when using the Master Code.

<i>Indicator</i>	<i>Definition</i>
On	System Is Armed In STAY Mode 1 Or STAY Mode 2
Off	System Is Not Armed In STAY Mode
Flashing	Zone Isolating Mode Or Setting STAY Mode 2 Zones
Once Every 3 Seconds	Day Alarm Status On/Off Indicator

Table 7: STAY Indicator

MAINS Indicator

The MAINS indicator is used to display that the systems AC mains supply is normal or has failed.

When programming numbers (i.e. Installer's Programming Mode or Master Code Functions), the MAINS indicator will illuminate when you program numbers between 10 and 15. The MAINS indicator represents digit 10 plus the value of the illuminated zone indicator (e.g.: If you program a twelve, the MAINS indicator and zone 2 will illuminate).

<i>Indicator</i>	<i>Definition</i>
On	AC Mains Power Normal
Flashing	AC Mains Failure

Table 8: MAINS Indicator

FAULT Indicator

The FAULT indicator is used to display that the system has detected a fault. Refer to Fault Descriptions on page 53 for more information on system faults.

Every time a new system fault has been detected (e.g.: FAULT indicator flashing), the codepad will begin to beep once every minute.

Pressing the **AWAY** button once will cancel the once a minute beep and acknowledge the fault (e.g.: FAULT indicator on).

<i>Indicator</i>	<i>Definition</i>
On	There Is A System Fault That Needs To Be Rectified
Off	The System Is Normal, There Are No Faults
Flashing	There Is A System Fault Waiting To Be Acknowledged

Table 9: FAULT Indicator

Audible Indicators

In general, the audible indications given out by the codepad are as follows:

<i>Indicator</i>	<i>Definition</i>
One Short Beep	A Button Has Been Pressed On The Codepad Or End Of Exit Time When Armed In Either STAY Mode 1 Or STAY Mode 2
Two Short Beeps	The System Has Accepted Your Code
Three Short Beeps	The Requested Function Has Been Executed
One Long Beep	Indicates The End Of Exit Time In AWAY Mode Or The Requested Operation Has Been Denied Or Aborted
One Short Beep Every Second	Walk Test Mode Is Currently Active Or Warning Before Automatic Arming Takes Place
One Short Beep Every Two Seconds	Telephone Monitor Mode Is Active
One Short Beep Every Minute	There Is A System Fault Waiting To Be Acknowledged

Table 10: Audible Indications

CP5 Eight Zone LCD Codepad

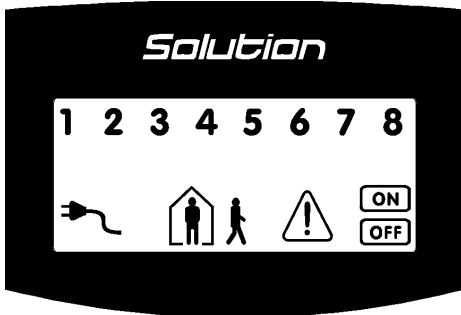

Figure 2: CP5 Eight Zone LCD Codepad (CP508L)

The codepad is the communications interface between you and your alarm system. The codepad allows you to issue commands and offers both visual and audible indications that guide you through the general operation.

The codepad incorporates numerous indicators. There are ZONE indicators that are used to show the condition of each zone and seven others for general status. The following is a list of situations and the relevant indications that will be seen.

Zone Indicators

1 2 3

The ZONE indicators are used to display the status of the zones. The following table lists the various circumstances that the indicators will display (i.e. Zone Sealed, Zone Unsealed).

<i>Indicator</i>	<i>Definition</i>
On	Zone Is Unsealed
Off	Zone Is Sealed
Flashing Fast (0.25 Sec On – 0.25 Sec Off)	Zone Is In Alarm Condition
Flashing Slow (1 Sec On – 1 Sec Off)	Zone Is Manually Isolated

Table 11: Zone Indicators

AWAY Indicator



The AWAY indicator is used to display that the system is armed in AWAY Mode. The **ON** indicator will also illuminate when the system is armed in AWAY Mode. The AWAY indicator will also flash in unison with the STAY indicator when Installer's Programming Mode or Master Code Functions are used.

Refer to page 40 for more information on the different methods on arming the system in AWAY Mode.

<i>Indicator</i>	<i>Definition</i>
On	System Is Armed In AWAY Mode
Off	System Is Not Armed In AWAY Mode

Table 12: AWAY Indicator



STAY Indicator

The STAY indicator is used to display that the system is armed in STAY Mode 1 or STAY Mode 2. The STAY indicator will also flash in unison with the AWAY indicator when Installer's Programming Mode or Master Code Functions are used.

The **ON** indicator will also illuminate when the system is armed in STAY Mode 1 or STAY Mode 2.

For the different methods of arming the system in STAY Mode 1, refer to page 42. Refer to Zone Options 2 on page 179 for information on setting zones to be automatically isolated in STAY Mode 1. For the method of arming the system in STAY Mode 2, refer to page 45. Refer to Setting STAY Mode 2 Zones on page 71 when using the Installer Code or Setting STAY Mode 2 Zones on page 86 when using the Master Code.

<i>Indicator</i>	<i>Definition</i>
On	System Is Armed In STAY Mode 1 Or STAY Mode 2
Off	System Is Not Armed In STAY Mode
Flashing	Zone Isolating Mode Or Setting STAY Mode 2 Zones
Once Every 3 Seconds	Day Alarm Status On/Off Indicator

Table 13: STAY Indicator

System Disarmed

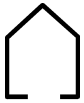

This indicator will illuminate with the **OFF** indicator when the system has been disarmed.

MAINS Indicator



The MAINS indicator is used to display that the systems AC mains supply is normal or has failed.

When programming numbers (i.e. Installer's Programming Mode or Master Code Functions), the MAINS indicator will illuminate when you program numbers between 10 and 15. The MAINS indicator represents digit 10 plus the value of the illuminated zone indicator (e.g.: If you program a twelve, the MAINS indicator and zone 2 will illuminate).

<i>Indicator</i>	<i>Definition</i>
On	AC Mains Power Normal
Flashing	AC Mains Failure

Table 14: MAINS Indicator



FAULT Indicator

The FAULT indicator is used to display that the system has detected a fault. Refer to Fault Descriptions on page 53 for more information on system faults.

Every time a new system fault has been detected (e.g.: FAULT indicator flashing), the codepad will begin to beep once every minute.

Pressing the **AWAY** button once will cancel the once a minute beep and acknowledge the fault (e.g.: FAULT indicator on).

<i>Indicator</i>	<i>Definition</i>
On	There Is A System Fault That Needs To Be Rectified
Off	The System Is Normal, There Are No Faults
Flashing	There Is A System Fault Waiting To Be Acknowledged

Table 15: FAULT Indicator

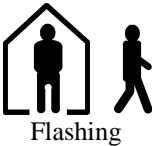

Programming Mode

These two indicators will flash when the system has entered either Installer's Programming Mode or when any Master Code Functions are used.

Off Indicator/Zone Sealed



The **OFF** indicator will illuminate when the system is in the disarmed state or Installer's Programming Mode has been entered and will flash when a zone becomes unsealed during the disarmed state. The indicator will stop flashing when all zones are sealed.

On Indicator/Zone In Alarm



The **ON** indicator will illuminate when the system is armed in AWAY Mode and will flash when an alarm occurs. The indicator will reset once a valid user code has been entered.

Audible Indicators

In general, the audible indications given out by the codepad are as follows:

<i>Indicator</i>	<i>Definition</i>
One Short Beep	A Button Has Been Pressed On The Codepad Or End Of Exit Time When Armed In Either STAY Mode 1 Or STAY Mode 2
Two Short Beeps	The System Has Accepted Your Code
Three Short Beeps	The Requested Function Has Been Executed
One Long Beep	Indicates The End Of Exit Time In AWAY Mode Or The Requested Operation Has Been Denied Or Aborted
One Short Beep Every Second	Walk Test Mode Is Currently Active Or Warning Before Automatic Arming Takes Place
One Short Beep Every Two Seconds	Telephone Monitor Mode Is Active
One Short Beep Every Minute	There Is A System Fault Waiting To Be Acknowledged

Table 16: Audible Indications

CP5 Master Partitioned LED Codepad

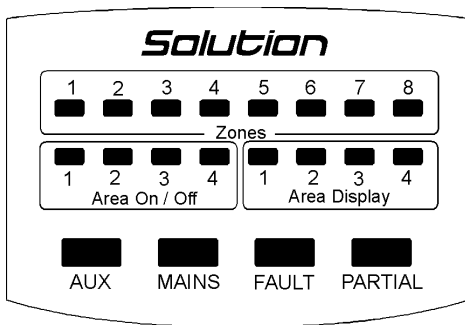

Figure 3: CP5 Master Partitioned LED Codepad (CP500P)

This codepad is only used on the *Solution Ultima 880* control panel when partitioned. The Master Partitioned LED codepad will allow the user to operate both areas individually from the same codepad, without the need to operate individual areas from separate codepads.

The codepad is the communications interface between you and your alarm system. The codepad allows you to issue commands and offers both visual and audible indications that guide you through the general operation.

The codepad incorporates numerous indicators. There are ZONE indicators that are used to show the condition of each zone and four others for general status. The following is a list of situations and the relevant indications that will be seen.

Refer to Partitioning on page 235 for more information.

The indicators on the CP5 Master Partitioned LED codepad are configured in to four groups. Following is a description of what the indicators mean.

Zone Indicators

- The ZONE indicators are used to display the status of the zones. The following table lists the various circumstances that the indicators will display (i.e. Zone Sealed, Zone Unsealed).

Indicator	Definition
On	Zone Is Unsealed
Off	Zone Is Sealed
Flashing Fast (0.25 Sec On – 0.25 Sec Off)	Zone Is In Alarm Condition
Flashing Slow (1 Sec On – 1 Sec Off)	Zone Is Manually Isolated

Table 17: Zone Indicators

Area On/Off Indicators

- The group of four Area On/Off indicators (1 – 4) show the status of each area (i.e. If an indicator is illuminated, that area is armed and if the indicator is not illuminated, that area is disarmed).

If an area is armed in STAY Mode 1, the corresponding Area On/Off indicator will be illuminated in conjunction with the PARTIAL indicator. If the area is armed in AWAY Mode, only the corresponding Area On/Off Indicator will be illuminated.

Area On/Off Indicator	Definition
On	Area Is Armed In AWAY Mode Or STAY Mode 1
Off	Area Is Disarmed

Table 18: Area On/Off Indicators

Area Display Indicators

3

A group of four Area Display indicators display which area is currently being displayed (i.e. If number 1 is being displayed, all information provided on the codepad display relates only to Area 1. If number 2 is being displayed, all information provided on the codepad display relates only to Area 2).

Pressing the **AWAY** button will toggle or move you to the next area display (i.e. If Area 1 is currently being displayed, pressing the **AWAY** button will toggle or move you to Area 2. Pressing the **AWAY** button a second time will toggle you back to display information for Area 1).

<i>Area Display Indicators</i>	<i>Definition</i>
On	Indicates Current Area Being Displayed
Off	Indicates Current Area Not Being Displayed

Table 19: Area Display Indicators

Status Indicators

4

A group of four indicators display the following:

PARTIAL Indicator

The PARTIAL indicator is used to display that the system is armed in STAY Mode 1. The PARTIAL indicator will also flash in unison with the AUX indicator when Installer’s Programming Mode or Master Code Functions are used.

For the different methods of arming the system in STAY Mode 1, refer to page 42. Refer to Zone Options 1 on page 169 for information on setting zones to be automatically isolated in STAY Mode 1.

<i>Indicator</i>	<i>Definition</i>
On	System Is Armed In STAY Mode 1
Off	System Is Not Armed In STAY Mode 1

Table 20: Partial Indicator

AUX Indicator

If Option 8 in “LOCATION 444” on page 241 has been enabled, the AUX indicator will be used to display when the control panel is using the telephone line. The AUX indicator will also flash in unison with the PARTIAL indicator when Installer’s Programming Mode or Master Code Functions are used.

<i>Indicator</i>	<i>Definition</i>
On	System Is Armed In STAY Mode 1 Or STAY Mode 2
Off	System Is Not Armed In STAY Mode
Flashing	Zone Isolating Mode Or Setting STAY Mode 2 Zones

Table 21: AUX Indicator

MAINS Indicator

The MAINS indicator is used to display that the systems AC mains supply is normal or has failed.

When programming numbers (i.e. Installer's Programming Mode or Master Code Functions), the MAINS indicator will illuminate when you program numbers between 10 and 15. The MAINS indicator represents digit 10 plus the value of the illuminated zone indicator (e.g.: If you program a twelve, the MAINS indicator and zone 2 will illuminate).

<i>Indicator</i>	<i>Definition</i>
On	AC Mains Power Normal
Flashing	AC Mains Failure

Table 22: MAINS Indicator

FAULT Indicator

The FAULT indicator is used to display that the system has detected a fault. Refer to Fault Descriptions on page 53 for more information on system faults.

Every time a new system fault has been detected (e.g.: FAULT indicator flashing), the codepad will begin to beep once every minute.

Pressing the **AWAY** button once will cancel the once a minute beep and acknowledge the fault (e.g.: FAULT indicator on).

<i>Indicator</i>	<i>Definition</i>
On	There Is A System Fault That Needs To Be Rectified
Off	The System Is Normal, There Are No Faults
Flashing	There Is A System Fault Waiting To Be Acknowledged

Table 23: FAULT Indicator

Audible Indicators

In general, the audible indications given out by the codepad are as follows:

<i>Indicator</i>	<i>Definition</i>
One Short Beep	A Button Has Been Pressed On The Codepad Or End Of Exit Time When Armed In Either STAY Mode 1 Or STAY Mode 2
Two Short Beeps	The System Has Accepted Your Code
Three Short Beeps	The Requested Function Has Been Executed
One Long Beep	Indicates The End Of Exit Time In AWAY Mode Or The Requested Operation Has Been Denied Or Aborted
One Short Beep Every Second	Walk Test Mode Is Currently Active Or Warning Before Automatic Arming Takes Place
One Short Beep Every Two Seconds	Telephone Monitor Mode Is Active
One Short Beep Every Minute	There Is A System Fault Waiting To Be Acknowledged

Table 24: Audible Indications

System Operations

This section includes the following:

- *Arming The System In AWAY Mode*
- *Disarming The System From AWAY Mode*
- *Arming The System In STAY Mode 1*
- *Disarming The System From STAY Mode 1*
- *Arming The System In STAY Mode 2*
- *Disarming The System From STAY Mode 2*
- *Codepad Duress Alarm*
- *Codepad Panic Alarm*
- *Codepad Fire Alarm*
- *Codepad Medical Alarm*
- *Isolating Zones*
- *Fault Analysis Mode*

System Operations

This section explains the general operations of the system. The operations will explain how to arm and disarm the system in the various modes, how to isolate zones, initiate codepad alarms and determine any fault that may occur.

Arming The System In AWAY Mode

Arming the system in AWAY Mode is normally performed when you leave the premises and require that all zones be activated in a ready state to detect any intrusion.

There are two different methods for arming the system in AWAY Mode. Method one is standard and will always operate. Method two is optional and requires Option 2 in "LOCATION 441" to be enabled on page 232.

If you require to isolate a zone(s) prior to arming the system in AWAY Mode, refer to Isolating Zones on page 48.



Single button arming in AWAY Mode will report as user code number 16.

Method One

How To Arm The System In AWAY Mode

1. Enter your **CODE** followed by the **AWAY** button.
Two beeps will be heard and the AWAY indicator will illuminate. Exit time will now commence.



Method Two

How To Arm The System In AWAY Mode

1. Hold down the **AWAY** button until two beeps are heard.
The AWAY indicator will illuminate and exit time will now commence. Refer to Option 2 in "LOCATION 441" on page 232 to enable single button arming in AWAY Mode.

If a zone is not sealed at the end of exit time, the zone will be automatically isolated and will be constantly illuminated on the remote codepad. The zone will again become an active part of the system as soon as it has resealed (i.e.. If a window is left open after exit time has expired, the window will not be an active part of the system until it has closed. Opening the window after exit time has expired will cause an alarm condition).



Forced Arming

The feature of arming the system when a zone is not sealed is known as forced arming. Refer to Zone Options 2 on page 179 to enable forced arming for each zone.

If the AWAY indicator does not illuminate and a long beep is heard when attempting to arm the system in AWAY Mode, forced arming is not permitted. If this is the case, you must ensure that all zones are sealed or manually isolated before you can arm the system.

Disarming The System From AWAY Mode

When you enter the premises after the system has been armed in AWAY Mode, you will need to disarm the system from AWAY Mode to disable detection devices that will activate the sirens, strobe and bell outputs.

If there has been an alarm condition prior to disarming the system from AWAY Mode, a flashing ZONE indicator will be displayed, indicating a previous alarm on that zone.

How To Disarm The System From AWAY Mode

1. Enter your **CODE** followed by the **AWAY** button.
Two beeps will be heard and the AWAY indicator will extinguish.



Arming The System In STAY Mode 1

Arming the system in STAY Mode 1 is only used when the perimeter and unused areas of the premises need to be armed to detect any would be intruder from entering the premises, at the same time allowing you to move freely within an area which has been automatically isolated.

Only the installer can program zones to be automatically isolated in STAY Mode 1. Refer to Zone Options 2 on page 179 for further information on setting zones to be automatically isolated in STAY Mode 1.

There are two methods for arming your system in STAY Mode 1. Method one is standard and will always operate. Method two is optional and requires Option 2 in "LOCATION 441" to be enabled on page 232.

When reporting back to base, a "Partial Close" report (Contact ID Event Code 456) will be sent.

Entry Guard Timer For STAY Mode

When arming the system in STAY Mode 1, an optional entry timer called Entry Guard Timer For STAY Mode may be used to delay the sirens, strobe and bell outputs if a zone that has not been automatically isolated has triggered into alarm condition. Entry Guard Timer For STAY Mode is the delay time used for all zones except 24 hour zones when the system is armed in STAY Mode 1 or STAY Mode 2.

If the Entry Guard Timer For STAY Mode has been programmed and a zone that has not been automatically isolated has triggered, the codepad will beep twice a second until the Entry Guard Timer For STAY Mode has expired or the system has been disarmed. If the alarm condition has not been reset before Entry Guard Timer For STAY Mode expires, the strobe, bell and siren outputs will activate into alarm.



Single button arming in STAY Mode 1 will report as user code number 16.

Method One

How To Arm The System In STAY Mode 1

1. Enter your **CODE** followed by the **STAY** button.
Two beeps will be heard and the STAY indicator will illuminate. Exit time will now commence.

Any zones that have been programmed to be automatically isolated in STAY Mode 1 will begin to flash until exit time expires. At the end of exit time, the ZONE indicators will extinguish and the codepad will give one short beep.

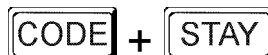

Method Two

How To Arm The System In STAY Mode 1

1. Hold down the  button until two beeps are heard. The STAY indicator will illuminate and exit time will now commence.

Any zones that have been programmed to be automatically isolated in STAY Mode 1 will begin to flash until exit time expires. At the end of exit time, the ZONE indicators will extinguish and the codepad will give one short beep.



If a zone is not sealed at the end of exit time, the zone will be automatically isolated and will be constantly illuminated on the remote codepad. The zone will again become an active part of the system as soon as it has resealed (i.e.. If a window is left open after exit time has expired, the window will not be an active part of the system until it has closed. Opening the window after exit time has expired will cause an alarm condition).

Forced Arming

The feature of arming the system when a zone is not sealed is known as forced arming. Refer to Zone Options 2 on page 179 to enable forced arming for each zone.

If the STAY indicator does not illuminate and a long beep is heard when attempting to arm the system in STAY Mode 1, forced arming is not permitted. If this is the case, you must ensure that all zones are sealed or manually isolated before you can arm the system.

Disarming The System From STAY Mode 1

There are two methods for disarming the system from STAY Mode 1. Method one is standard and will always operate. Method two is optional and needs Option 4 to be enabled in "LOCATION 441" on page 232.

Method One

How To Disarm The System From STAY Mode 1

1. Enter your **CODE** followed by the **STAY** button.
Two beeps will be heard and the STAY indicator will extinguish. The system is now disarmed.



Method Two

A flashing ZONE indicator represents a previous alarm on that zone. If this is the case, a valid user code will need to be used to disarm the system using method one. To enable method two, Option 4 in "LOCATION 441" on page 232 will need to be enabled.

How To Disarm The System From STAY Mode 1

1. Hold down the **STAY** button until two beeps are heard.
The STAY indicator will extinguish and the system is now disarmed.



Single button disarming from STAY Mode 1 will report as user code number 16.

Arming The System In STAY Mode 2

Arming the system in STAY Mode 2 is only used when the perimeter and unused areas of the premises need to be armed to detect any would be intruder from entering the premises, at the same time allowing you to move freely within an area which has been automatically isolated.

Programming zones to be automatically isolated in STAY Mode 2 can be programmed either by the Installer Code Function – Setting STAY Mode 2 Zones on page 71 or Master Code Functions - Setting STAY Mode 2 Zones on page 86.

When reporting back to base, a “Partial Close” report (Contact ID Event Code 456) will be sent.

Entry Guard Timer For STAY Mode

When arming the system in STAY Mode 2, an optional entry timer called Entry Guard Timer For STAY Mode may be used to delay the sirens, strobe and bell outputs if a zone that has not been automatically isolated has triggered into alarm condition. Entry Guard Timer For STAY Mode is the delay time used for all zones except 24 hour zones when the system is armed in STAY Mode 1 or STAY Mode 2.

If the Entry Guard Timer For STAY Mode has been programmed and a zone that has not been automatically isolated has triggered, the codepad will beep twice a second until the Entry Guard Timer For STAY Mode has expired or the system has been disarmed. If the alarm condition has not been reset before Entry Guard Timer For STAY Mode expires, the strobe, bell and siren outputs will activate into alarm.



Single button arming in STAY Mode 2 will report as user code number 16.

How To Arm The System In STAY Mode 2

1. Hold down the  button until two beeps are heard.
The STAY indicator will illuminate and exit time will now commence.

Any zones that have been programmed to be automatically isolated in STAY Mode 2 will begin to flash until exit time expires. At the end of exit time, the ZONE indicators will extinguish and the codepad will give one short beep.



If a zone is not sealed at the end of exit time, the zone will be automatically isolated and will be constantly illuminated on the remote codepad. The zone will again become an active part of the system as soon as it has resealed (i.e.. If a window is left open after exit time has expired, the window will not be an active part of the system until it has closed. Opening the window after exit time has expired will cause an alarm condition).

Forced Arming

The feature of arming the system when a zone is not sealed is known as forced arming. Refer to Zone Options 2 on page 179 to enable forced arming for each zone.

If the STAY indicator does not illuminate and a long beep is heard when attempting to arm the system, forced arming is not permitted. If this is the case, you must ensure that all zones are sealed or manually isolated before you can arm the system.

Disarming The System From STAY Mode 2

There are two methods for disarming the system from STAY Mode 2. Method one is standard and will always operate. Method two is optional and requires Option 4 to be enabled in "LOCATION 441" on page 232.

Method One

How To Disarm The System From STAY Mode 2

1. Enter your **CODE** followed by the **STAY** button.
Two beeps will be heard and the STAY indicator will extinguish. The system is now disarmed.



Method Two

A flashing ZONE indicator represents a previous alarm on that zone. If this is the case a valid user code will need to be used to disarm the system using method one. To enable method two, Option 4 in "LOCATION 441" on page 232 will need to be programmed.

How To Disarm The System From STAY Mode 2

1. Hold down the **O** button until two beeps are heard.
The STAY indicator will extinguish and the system is now disarmed.



Single button disarming from STAY Mode 2 will report as user code number 16.

Codepad Duress Alarm

A codepad duress alarm is used as a silent hold up alarm. This will only occur when the number 9 is added to the end of any valid user code that is being used to disarm the system. However, if a user code has a priority level of arming only, entering their user code followed by 9 will still send a duress alarm when the system is armed.

A duress alarm (Contact ID Event Code 121) is only useful if your system is reporting back to a monitoring station or pocket pager as domestic reporting format can't decipher which type of alarm had occurred. If you wish to disable the codepad duress alarm report, refer to "LOCATION 348" on page 190 for more information. If you require to activate a duress alarm by adding a number 3 to the end of any valid user code being used to disarm the system, enable Option 2 in "LOCATION 442" on page 233.



Codepad Panic Alarm

An audible codepad panic alarm will be activated when both the 1 and 3 buttons or both the STAY and AWAY buttons are pressed simultaneously.

Refer to Option 1 in "LOCATION 437" on page 228 if you wish to program codepad panic to be silent. If you wish to disable the codepad panic alarm report, refer to "LOCATION 349 - 350" on page 190 for more information. A codepad panic alarm will send a Contact ID Event Code 120 when reporting back to a base station receiver.

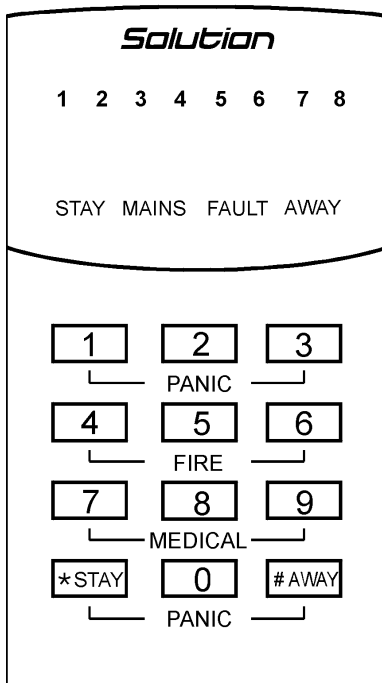
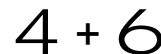

Figure 4: CP5 LED Codepad Showing Audible Alarm Buttons

Codepad Fire Alarm

An audible codepad fire alarm will be activated when both the 4 and 6 buttons on the remote codepad are pressed simultaneously. A distinct fire sound is emitted through the horn speaker to indicate this type of alarm condition. The fire sound is different to the burglary sound.

Refer to Option 2 in "LOCATION 437" on page 228 if you wish to program codepad fire to be silent. If you wish to disable the codepad fire alarm report, refer to "LOCATION 351 - 352" on page 191 for more information. A codepad fire alarm will send a Contact ID Event Code 110 to a base station receiver.



Codepad Medical Alarm

An audible codepad medical alarm will be triggered when both the 7 and 9 buttons on the remote codepad are pressed simultaneously.

Refer to Option 4 in "LOCATION 437" on page 228 if you wish to program codepad medical to be silent. If you wish to disable the reporting of the codepad medical alarm report, refer to "LOCATION 353 - 354" on page 191 for more information. A codepad medical alarm will send a Contact ID Event Code 100 to a base station receiver.

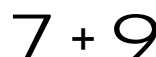

Isolating Zones

Isolating zones allow you to manually disable one or more zones before arming the system in AWAY Mode, STAY Mode 1 or STAY Mode 2. Once a zone has been isolated, access is allowed into that zone during the armed state without activating the sirens or dialler.

An example when you may require to isolate a zone before arming in AWAY Mode, STAY Mode 1 or STAY Mode 2 may be when a zone PIR detector may be false alarming or that you may need to leave a pet inside a particular zone whilst you are away.

Isolating zones is performed by one of two methods. One way requires the use of a valid user code while the other way does not. The ability to isolate zones is governed by the priority level allocated to each user code holder. Some user code holders may not be able to isolate zones. Refer to User Code Priority on page 161 for further information. At factory default, the standard method for isolating zones is used.

Zones that have been manually isolated using this method will send a zone bypass report (Contact ID Event Code 570) for each zone upon arming the system. A zone bypass restore report will be sent when the system has been disarmed.

When you select a 24-hour burglary zone to be isolated, a Contact ID Event Code 572 will be sent. If you select a 24-hour fire zone to be isolated, a Contact ID Event Code 571 will be sent.

Standard Isolating

Standard isolating allows all operators to be able to isolate zones. Therefore, no code is required to be used when isolating zones.

1. Press the **STAY** button twice.
Three beeps will be heard and the STAY indicator will begin to flash.
2. * Enter the **ZONE NUMBER** required to be isolated followed by the **STAY** button.
The zone you just selected to be isolated will now begin to flash.

24-hour zones will automatically isolate as soon as the **STAY** button has been pressed. All other burglary zones will automatically isolate only after the system has been armed.

Repeat Step 2 if more than one zone is required to be isolated until all zones that are required to be isolated have been selected.

3. Press the **AWAY** button when finished selecting the zones to be isolated.
Two beeps will be heard and the system will return to the disarmed state.

The zones selected to be isolated when you arm the system in AWAY Mode, STAY Mode 1 or STAY Mode 2 will continue to flash until the system has next been disarmed.



STAY + **STAY** + **ZONE NUMBER** + **STAY** + **AWAY**



- * As each zone is selected to be isolated, the corresponding ZONE indicator will begin to flash. If a mistake is made, press the zone number that was incorrectly entered followed by the **STAY** button. This zone is now no longer selected to be isolated and the ZONE indicator will extinguish.

Example

If you wish to manually isolate zones 1, 3 and 4, the following sequence would be entered below;



STAY + **STAY** + **1** + **STAY** + **3** + **STAY**
+ **4** + **STAY** + **AWAY**

Code To Isolate

The method of code to isolate restricts only those user codes that have the priority level Code To Isolate set to be able to isolate zones. Therefore, if any user code has this priority level set, the method of standard isolating will be disabled.

1. Press the **STAY** button.
2. Enter your **CODE** followed by the **STAY** button.
Three beeps will be heard and the STAY indicator will begin to flash. If you attempt to enter isolating mode with a user code that has not been allocated for code to isolate, the system will ignore the attempt to enter the mode.
3. * Enter the **ZONE NUMBER** required to be isolated followed by the **STAY** button. The zone you have just selected to be isolated will now begin to flash.

24-hour zones will automatically isolate as soon as the **STAY** button has been pressed. All other burglary zones will automatically isolate only after the system has been armed.

Repeat Step 3 if more than one zone is required to be isolated until all zones that are required to be isolated have been selected.

4. Press the **AWAY** button when finished selecting the zones to be isolated.
Two beeps will be heard and the system will return to the disarmed state.

The zones selected to be isolated when you arm the system in AWAY Mode, STAY Mode 1 or STAY Mode 2 will continue to flash until the system has next been disarmed.



STAY + **CODE** + **STAY**
 + **ZONE NUMBER** + **STAY** + **AWAY**



- * As each zone is selected to be isolated, the corresponding ZONE indicator will begin to flash. If a mistake is made, press the zone number that was incorrectly entered followed by the **STAY** button. This zone is now no longer selected to be isolated and the ZONE indicator will extinguish.

Example

If you wish to manually isolate zones 1, 3 and 4, the following sequence would be entered below;



STAY + **CODE** + **STAY**
 + **1** + **STAY** + **3** + **STAY** + **4** + **STAY** + **AWAY**

Fault Analysis Mode

If a fault should occur, the FAULT or MAINS indicator will flash and the codepad will beep once every minute.

If the AC mains supply has failed, the MAINS indicator will flash until the AC mains supply has restored. Pressing the  button once will acknowledge the fault and stop the codepad from beeping once every minute.

How To Determine The Type Of System Fault

To determine all system faults other than the AC mains supply, enter fault analysis mode by following the steps outlined below.

1. Hold down button  until two beeps are heard. The FAULT indicator will remain steady and the STAY and AWAY indicators will flash in unison with each other.

Any zone indicators displayed indicate the type of fault that has occurred. Refer to Table 25: Fault Indicators on page 52 for the list of different system faults that may occur.
2. To further determine the fault condition, you will need to hold down the corresponding button to that of the zone indicator displayed.
3. To exit fault analysis mode and return to the disarmed state, press the  button. The FAULT indicator will remain displayed and the codepad will cease its once a minute beep.

<i>Zone Indicator</i>	<i>Fault Description</i>	<i>Hold Down Button</i>	<i>Zone Indicator</i>	<i>Fault Condition</i>
1	System Fault	1	1	Low Battery
			2	Date & Time
			3	RF Receiver Jamming
				RF Receiver Tamper Switch
				RF Receiver Comms Failure
			4	Horn Speaker
			5	Telephone Line Fail
			6	E2 Fault
			7	Fuse Fail
2	RF Low Battery	2	1 - 8	Zones 1 - 8 RF Low Battery
3	Zone Tamper Alarm	3	1 - 8	Zones 1 - 8 Tamper Alarm
4	Sensor Watch Fault	4	1 - 8	Zones 1 – 8 Sensor Watch Fail
5	RF Sensor Watch	5	1 – 8	Zones 1 - 8 RF Sensor Watch Fail
6	Communication Fail	6	1	Receiver 1 Fail
			2	Receiver 2 Fail

Table 25: Fault Indicators

Fault Descriptions

1 System Fault

A system fault will only display when any of the following faults occur. After entering fault analysis mode, holding down button **1** will determine which of the following faults have occurred.

Low Battery

A low battery fault will register when the system detects a low capacity back-up battery. The system automatically performs a battery test every 4 hours and also every time you arm the system.

Date and Time

The date and time fault will register every time the system has been powered down. This type of fault will not cause the FAULT indicator to display on the codepad unless your installer has programmed the automatic arming time. To program the date and time, refer to page 89.

RF Receiver Fail

The RF receiver fault will register once the system has detected that the RF wireless receiver unit has registered RF Jamming, the RF wireless receiver has been disconnected from the control panel or has failed, or the RF receiver's cover tamper switch has been activated.

Horn Speaker

This fault will register when the system detects that the horn speaker has been disconnected. This fault will clear once the horn speaker has been reconnected. Your installer will need to program the system for this feature to operate.

Telephone Line Fail

A telephone line fault will register when the system detects that the telephone line has been disconnected from the control panel. Your installer will need to program the system for this feature to operate.

E2 Fault

An E2 fault will register when the system detects an internal checksum error. Contact your installer as soon as this fault is displayed.

Fuse Fail

This fault will occur when either of the two 1 Amp fuses has blown. Contact your installer as soon as this fault is displayed.

2 RF Low Battery

This fault will occur when any wireless zone (1 – 8) has reported a low battery condition to the control panel. Whilst you are in fault analysis mode, holding down button **2** until two beeps are heard will display which zone has reported the RF Low Battery fault.

3 *Tamper Fail*

This fault will occur when any zone has become open circuit. By holding down button **3** until two beeps are heard in fault analysis mode will display which zone has reported the tamper fail fault.

4 *Sensor Watch Fault*

A sensor watch fault will register because one or more detection devices has failed to detect any intrusion during the disarmed state for the time period programmed by your installer. The fault will clear once the zone in question has detected movement and reset.

Whilst you are in fault analysis mode, holding down button **4** until two beeps are heard will display which zone reported the sensor watch fault.

5 *RF Sensor Watch Fault*

An RF sensor watch fault will register because one or more wireless detection devices has failed to detect any intrusion during the disarmed state for the time period programmed by your installer. The fault will clear once the zone in question has detected movement and reset.

Whilst you are in fault analysis mode, holding down button **5** until two beeps are heard will display which zone reported the sensor watch fault.

6 *Communication Fail*

A communication fail will register when the control panel failed to communicate with the receiving party (e.g.: monitoring company, mobile phone or pocket pager etc).

The communication fault will clear once the control panel has successfully reported to the receiving party.

Whilst you are in fault analysis mode, holding down the **6** button until two beeps are heard will display which communication fault has occurred (i.e.. 1 = Receiver 1 / 2 = Receiver 2).

AC Mains Failure

An AC mains supply failure will automatically flash the MAINS indicator. If the AC mains supply has been disconnected continuously for more than two minutes, the remote codepad will beep the codepad buzzer once every minute. If the control panel has been programmed to report an AC mains fail to a base station receiver, an "AC Fail" report (Contact ID Event Code 301) will be sent.

The MAINS indicator will cease to flash as soon as the AC mains supply has been reconnected. When the AC mains supply has been continuously connected for a period of two minutes, the codepad will cease the once a minute beep and an "AC Fail" restore report will be sent to the base station receiver.

If Option 1 – Enable AC Fail In 1 Hour in "LOCATION 438" on page 229 has been enabled, the codepad will flash the MAINS indicator as soon as the AC mains supply has been disconnected and will not activate the dialler or the codepad buzzer unless the AC mains supply has been disconnected continuously for a period of 1 hour.

If Option 2 – Ignore AC Mains Fail in "LOCATION 438" on page 229 has been enabled, the codepad will not indicate when the AC mains supply has failed, but the control panel will still report if enabled an "AC Fail" report.

Remote Radio Transmitter Operations

This section includes the following;

- *Remote Radio Transmitter Operations*
- *Indications Upon Remote Radio Transmitter Operations*
- *Remote Radio User Code Priority Levels*
- *Changing Or Deleting Remote Radio User Codes*

Remote Radio Transmitter Operations

The *Solution Ultima 844/862/880* control panel has the ability to be remotely operated using hand held radio remote Transmitters. There is a choice of using either a 2-channel hand held Transmitter or a 4-channel hand held Transmitter to operate the system.

Both the 2 channel and 4-channel hand held Transmitters can remotely arm and disarm the system in AWAY Mode and activate remote panic alarms. However, the 4 channel hand held Transmitter has the added ability to arm the system in STAY Mode 1 and to operate the control panels programmable outputs (e.g.: Allowing you to activate a garage door or outside lights etc).

Before any hand held radio Transmitter can operate the control panel, you will need to teach the control panel the Transmitters radio code. Refer to Changing Or Deleting Remote Radio User Codes on page 58 for more information.

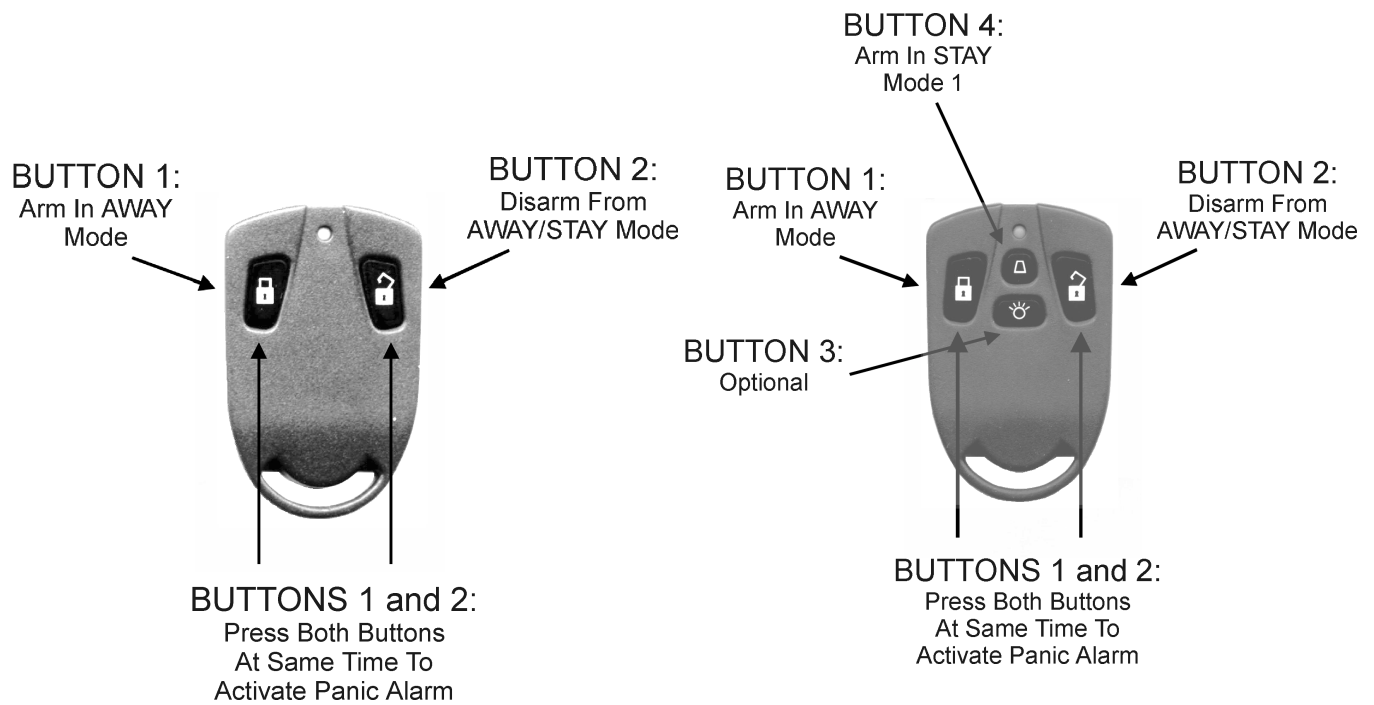

Indications Upon Remote Radio Transmitter Operations

When using either the 2-channel or 4-channel hand held transmitters to operate the system, audible and/or visual indications can be provided via the horn speakers or the strobe. This will allow you to operate the system from outside the premises with confidence. Only the installer can program the feature of audible and/or visual indication beeps.

Refer to Option 4 – Allow Strobe Indications For Radio Arm/Disarm and Option 8 – Assign Button 4 On Transmitter To Operate STAY Mode 1 in “LOCATION 436” on page 227. Refer to “LOCATION 435” on page 221 to set the volume of speaker beeps.

<i>No Of Beeps</i>	<i>System Status</i>
1	System Disarmed
2	System Armed In AWAY Mode
1 Two Tone Beep	System Armed In STAY Mode 1

Table 26: Horn Speaker Indication Beeps For Remote Operations

<i>Strobe Duration</i>	<i>System Status</i>
3 Seconds	System Disarmed
6 Seconds	System Armed In AWAY Mode
6 Seconds	System Armed In STAY Mode 1

Table 27: Strobe Indications For Remote Operations

Remote Radio User Code Priority Levels

The radio remote hand held Transmitters may only be programmed to operate as user codes 9 - 16. Priority levels can be allocated to each radio remote hand held Transmitter, allowing the Transmitter to only arm the system or arm and disarm the system. Refer to User Code Priority on page 161 for more information.

Before any hand held radio Transmitter can operate the control panel, you will need to teach the control panel the Transmitters radio code. Refer to Changing Or Deleting Remote Radio User Codes on page 58 for more information.

Changing Or Deleting Remote Radio User Codes

Up to eight remote radio hand held Transmitters (User Codes 9 – 16) may be used to operate the system. Before the control panel will accept any of the signals from any radio remote hand held Transmitter, the control panel must learn the code of the Transmitter.



You may substitute the Master Code with the Installer Code if required to perform the function of changing or deleting remote radio user codes.

How To Add Or Change A Remote Radio User Code

1. Enter your **MASTER CODE** followed by **1** and the **AWAY** button.
Three beeps will be heard and the STAY and AWAY indicators will begin to flash.
2. Enter the **USER NUMBER** (9-16) that you wish to add or change followed by the **AWAY** button.

Two beeps will be heard and the corresponding codepad indicators will illuminate. Refer to "Table 28: Codepad Indicators Showing Relative Remote User Numbers" on page 59.

3. Enter the **RF 9-Digit ID No** found on the back of the radio remote hand held Transmitter followed by the **AWAY** button. Two beeps will be heard and the STAY and AWAY indicators will extinguish.

If you wish to add or change additional remote radio user codes, repeat this procedure as many times as required.

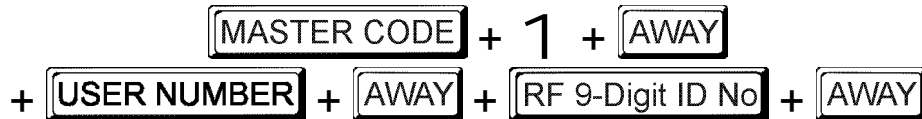

When adding or changing remote radio user codes, this function will automatically terminate if a button is not pressed within sixty seconds or by pressing the **AWAY** button. One long beep indicates the code entered already exists or an incorrect user number has been selected.

Radio remote user codes must be allocated to one or more areas when operating a Solution Ultima 880 control panel that has been partitioned. Refer to User Code Allocations on page 245 for more information.

How To Delete A Remote Radio User Code

1. Enter your **MASTER CODE** followed by **1** and the **AWAY** button.
Three beeps will be heard and the STAY and AWAY indicators will begin to flash.
2. Enter the **USER NUMBER** (9-16) that you wish to delete followed by the **AWAY** button.
Two beeps will be heard and the corresponding ZONE indicator will illuminate. Refer to “Table 28: Codepad Indicators Showing Relative Remote User Numbers” on page 59.
3. Press the **STAY** button to delete the user code.
Two beeps will be heard and the STAY and AWAY indicators will extinguish.

If you wish to delete additional remote radio user codes, repeat this procedure as many times as required.

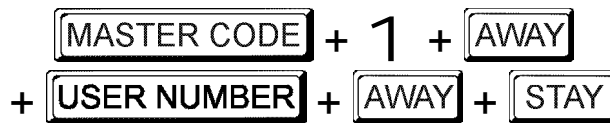

When deleting remote radio user codes, this function will automatically terminate if a button is not pressed within sixty seconds or by pressing the **AWAY** button. One long beep indicates the an incorrect user number has been selected.

User No	Zone 1 Indicator	Zone 2 Indicator	Zone 3 Indicator	Zone 4 Indicator	Zone 5 Indicator	Zone 6 Indicator	Zone 7 Indicator	Zone 8 Indicator	MAINS Indicator
9	✓							✓	
10									✓
11	✓								✓
12		✓							✓
13			✓						✓
14				✓					✓
15					✓				✓
16						✓			✓

Table 28: Codepad Indicators Showing Relative Remote User Numbers

System Functions

This section includes the following:

- *Installer Code Functions*
- *Master Code Functions*
- *Hold Down Functions*

System Functions

This section explains the more advanced features that are required for testing and regular maintenance of the system. Features such as Installer Code Functions, Master Code Functions and Hold Down Functions are covered in this section.

Installer Code Functions

Installer Code Functions allow the installer to perform various system tests without the need to know a Master Code. These functions can only be carried out when the system is in the disarmed state.

To enter the required Installer Code function, enter the **INSTALLER CODE** followed by the required **FUNCTION** digit and the **AWAY** button. All available Installer Code functions are listed in “Table 29: Installer Code Functions” outlined below.



INSTALLER CODE + **FUNCTION** + **AWAY**

<i>Function</i>	<i>Description</i>	<i>Page</i>
0	Add / Delete RF Wireless Devices	63/64
1	Set Number Of Days Until The First Test Report	65
2	Change Domestic Telephone Numbers	66
3	Change Telco Arm/Disarm Sequence	68
4	Setting STAY Mode 2 Zones	71
5	EDMSAT - Satellite Siren Service Mode	72
6	Turning Telephone Monitor Mode On/Off	73
7	Walk Test Mode	74
8	Event Memory Recall Mode	75

Table 29: Installer Code Functions

Adding Or Deleting RF Wireless Devices

0

The control panel has the ability to accept a maximum total of 16 wireless devices on any or all of the 8 zones that are used by the system. This means that it is possible to connect wireless PIR's, reed switches and smoke detectors directly to the control panel. Each zone can have multiple wireless devices allocated (e.g.: Zone 1 may have 16 wireless devices allocated and the remaining seven zones are hard wired). Refer to RF Device Mapping (Devices 1 – 8) and RF Device Mapping (Devices 9 – 16) on page 250 for more information.

How To Program A RF Wireless Device

1. Enter your **INSTALLER CODE** followed by **0** and the **AWAY** button. Three beeps will be heard and the STAY and AWAY indicators will begin to flash.
2. Enter the **RF DEVICE No** (1-16) that you wish to change followed by the **AWAY** button. Two beeps will be heard and the corresponding codepad indicators will illuminate to display the RF device number that you have selected.
3. Enter the **RF 9-Digit ID No** found on the back of the RF device followed by the **AWAY** button. Two beeps will be heard and the STAY and AWAY indicators will extinguish.

If you wish to program additional RF wireless devices, repeat this procedure as many times as required.



INSTALLER CODE + **0** + **AWAY**
 + **RF DEVICE No** + **AWAY** + **RF 9-Digit ID No** + **AWAY**



When adding RF devices, this function will automatically terminate if a button is not pressed within sixty seconds or by pressing the **AWAY button. One long beep indicates the code entered already exists or an incorrect user number has been selected.**

Example

If you require to program RF wireless device number 3 with a 9-digit ID number of 000094946, follow the steps outlined below and remember to substitute the default Installer Code (1234) with the Installer Code that you have programmed.



1 2 3 4 + **0** + **AWAY**
 + 3 + **AWAY**
 + 000094946 + **AWAY**

How To Delete A RF Wireless Device

1. Enter your **INSTALLER CODE** followed by **○** and the **AWAY** button.
Three beeps will be heard and the STAY and AWAY indicators will begin to flash.
2. Enter the **RF DEVICE No** (1-16) that you wish to delete followed by the **AWAY** button.
Two beeps will be heard and the corresponding codepad indicators will illuminate to display the RF device number that you have selected.
3. Press the **STAY** button to delete the RF device.
Two beeps will be heard and the STAY and AWAY indicators will extinguish.

If you wish to delete additional RF wireless devices, repeat this procedure as many times as required.

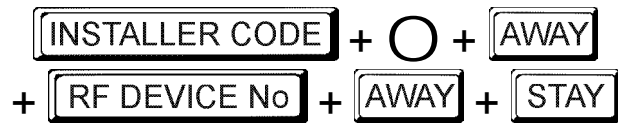

Set The Number Of Days Until The First Test Report

1

If you require the first test to report (Contact ID Event Code 602) the day after you are installing the control panel and you have programmed the repeat interval between each test report for every 7 days, you will need to set when the first test report will occur. If the first test report is not set using this Installer Code Function, the first test report will be sent to the base station receiver in the number of days programmed in the repeat interval. Refer to "LOCATION 372 - 378" on page 197 for setting the test report time and repeat interval.

How To Set The First Test Report

1. Enter your **INSTALLER CODE** followed by **1** and the **AWAY** button.
Three beeps will be heard and the STAY and AWAY indicators will begin to flash.
2. Enter the **No. OF DAYS** to wait (1 - 15 days) until the first test report is required.
3. Press the **AWAY** button when finished.
Two beeps will be heard and the STAY and AWAY indicators will extinguish. The system will now return to the disarmed state.



$$\begin{array}{c} \boxed{\text{INSTALLER CODE}} + 1 + \boxed{\text{AWAY}} \\ + \boxed{\text{No. OF DAYS}} + \boxed{\text{AWAY}} \end{array}$$

Each time you enter Installer's Programming Mode after you have set when the first test report will occur, the first test report time will default back to the repeat interval time between each test report as set in "LOCATION 378".



Test reports will not report if the Subscriber ID Number is 0000. The number of day's decrements by one at 00:00 hours as set in "LOCATION 901 – 904" on page 222.

Example

If you programmed the repeat interval in the test reports for every seven days, but wish to have the first test report to begin in two days time, follow the sequence outlined below;



$$\begin{array}{c} 1\ 2\ 3\ 4 + 1 + \boxed{\text{AWAY}} \\ + 2 + \boxed{\text{AWAY}} \end{array}$$

Changing Domestic Phone Numbers

2

When the system has been set up for domestic dialling, this function allows the installer to view and program the required telephone numbers that the system will call in the event of an alarm. For a more detailed description, refer to Domestic Dialling on page 125 for further information.

How To Change Domestic Phone Numbers

1. Enter your **INSTALLER CODE** followed by **2** and the **AWAY** button. Three beeps will be heard and the STAY and AWAY indicators will begin to flash.

If there are telephone numbers already programmed, they will be displayed one digit at a time via the remote codepad indicators. Refer to "Table 31: Codepad Indicators When Changing Telephone Numbers" on page 67 for the indicators and their meanings.

If there are no telephone numbers programmed, a further two beeps will be heard after entering this mode. These two beeps are normally heard after the last digit of the last telephone number has been displayed.

2. Enter all the digits for **PHONE No 1**, one digit at a time. You will notice as each digit is entered, the corresponding codepad indicators will illuminate.
3. If there is more than one telephone number, press the **STAY** button followed by the **4** button after the last digit of the telephone number. This will insert a break between the first telephone number and the second telephone number. If there is only one phone number, press the **AWAY** button to exit this mode.
4. Enter all the digits for **PHONE No. 2**, one digit at a time. You will notice as each digit is entered, the corresponding codepad indicators will illuminate.
5. After the last digit of the second telephone number, press the **AWAY** button to exit this mode unless a third telephone number is required. If there is a third telephone number to be programmed, press the **STAY** button followed by the **4** button to insert a break between the second telephone number and the third telephone.



INSTALLER CODE + **2** + **AWAY**
 + **PHONE No 1** + **STAY** + **4** + **PHONE No. 2** + **AWAY**

Digit Required	Number To Program	Digit Required	Number To Program
0	0	8	8
1	1	9	9
2	2		
3	3	*	STAY Followed By 1
4	4	#	STAY Followed By 2
5	5	Four Second Pause	STAY Followed By 3
6	6	Break	STAY Followed By 4
7	7	15	STAY Followed By 5

Table 30: Domestic Dialling Digits

Example

If you wish to program two separate telephone numbers (9672 1777 and 9672 1233), follow the sequence below and replace the telephone numbers mentioned in the manual with the telephone numbers that you wish to program.



1 2 3 4 + 2 + AWAY
 + 9 6 7 2 1 7 7 7 + STAY + 4
 + 9 6 7 2 1 2 3 3 + AWAY

How To Disable Domestic Dialling

If at any time you wish to cancel domestic dialling for any reason (e.g.. You are moving house and do not wish the system to continue calling your work place or mobile phone etc), you may enter the following sequence.



INSTALLER CODE + 2 + AWAY + STAY + 4 + AWAY

Digit	Zone 1 Indicator	Zone 2 Indicator	Zone 3 Indicator	Zone 4 Indicator	Zone 5 Indicator	Zone 6 Indicator	Zone 7 Indicator	Zone 8 Indicator	MAINS Indicator
0									✓
1	✓								
2		✓							
3			✓						
4				✓					
5					✓				
6						✓			
7							✓		
8								✓	
9	✓							✓	
*	✓								✓
#		✓							✓
Pause			✓						✓
Break				✓					✓
15					✓				✓

Table 31: Codepad Indicators When Changing Telephone Numbers

3

Change Telco Arm/Disarm Sequence

This feature allows you to program the Telco Arm Sequence (Option 1) and Telco Disarm Sequence (Option 2). This feature is only available if your telecommunication provider has the call forward option available.

Option 1 – Telco Arm Sequence

This allows you to program the Call Forward – Immediate On sequence or Call Forward – No Answer sequence that will automatically operate when you arm the system in the AWAY Mode.

Note: The examples given in this feature is only applicable to Australia.

Call Forward – Immediate On

You can redirect calls to anywhere in Australia, including mobiles, pagers and answering services. When Call Forward is turned on, your telephone will not ring.

Call Forward – No Answer

When your telephone is not answered within 20 seconds, this feature redirects all incoming calls to another number anywhere in Australia, but you can still make outgoing calls.

Option 2 – Telco Disarming Sequence

This allows you to automatically disable the call forward sequence upon disarming the system.

<i>Digit Required</i>	<i>Number To Program</i>	<i>Digit Required</i>	<i>Number To Program</i>
0	0	8	8
1	1	9	9
2	2		
3	3	*	STAY Followed By 1
4	4	#	STAY Followed By 2
5	5	Four Second Pause	STAY Followed By 3
6	6	Break	STAY Followed By 4
7	7		

Table 32: Telco Arm/Disarm Dialling Digits

How To Program Telco Arming Sequence

1. Enter your **INSTALLER CODE** followed by **3** and the **AWAY** button. Three beeps will be heard and the STAY and AWAY indicators will begin to flash.
2. Press button **1** followed by the **AWAY** button to change the telco arm sequence. Three beeps will be heard.

If a previous call forwarding sequence has already been programmed, the sequence will be displayed one digit at a time via the remote codepad indicators.

If there is no call forward sequence programmed, a further two beeps will be heard after entering this mode. These two beeps are normally heard after the last digit of the previous call forward sequence has been displayed.

3. Enter the call forward sequence that you require (e.g.: ***61 Phone Number #** if you wish to program the Call Forward – No Answer Sequence or ***21 Phone Number #** if you wish to program the Call Forward – Immediate Sequence).

Remember that when you program a * in the telco arm sequence, you enter *1 and when you program the # in the telco arm sequence, you enter *2.

4. Press the **AWAY** button when finished. Two beeps will be heard and the system will return to the disarmed state.

Example

If you wish to automatically divert all unanswered incoming calls to another telephone number (e.g.: 9672 1777) when the system is armed in AWAY Mode, follow the example sequence below and replace the telephone number mentioned in the manual with the telephone number that you wish to divert all calls to.



1 2 3 4 + 3 + **AWAY**
 + 1 + **AWAY**
 + **STAY** 1 6 1 + 9 6 7 2 1 7 7 7 + **STAY** 2
 + **AWAY**

How To Disable The Telco Arming Sequence

If at any time you wish to cancel the telco arming sequence, you may enter the following sequence.



INSTALLER CODE + 3 + **AWAY** + 1 + **AWAY**
 + **STAY** + 4 + **AWAY**

How To Program The Telco Disarm Sequence

1. Enter your **INSTALLER CODE** followed by **3** and the **AWAY** button. Three beeps will be heard and the STAY and AWAY indicators will begin to flash.
2. Press button **2** followed by the **AWAY** button to change the telco disarm sequence. Three beeps will be heard.

If a previous telco disarming sequence has already been programmed, the sequence will be displayed one digit at a time via the remote codepad indicators.

If no telco disarming sequence has been programmed, a further two beeps will be heard after entering this mode. These two beeps are normally heard after the last digit of the call forward sequence has been displayed.

3. Enter the call forward disable sequence that you require (e.g.: **#61#** if you wish to disable the Call Forward - No Answer sequence, or **#21#** if you wish to disable the Call Forward - Immediate On sequence.

Remember that when you program a # in the telco disarm sequence, you enter *2.

4. Press the # button when finished. Two beeps will be heard and the system will return to the disarmed state.



INSTALLER CODE + **3** + **AWAY**
2 + **AWAY**
STAY **261** **STAY** **2** + **AWAY**

How To Disable The Telco Disarm Sequence

If at any time you wish to cancel the telco disarm sequence, you may enter the following sequence.



INSTALLER CODE + **3** + **AWAY** + **2** + **AWAY**
+ **STAY** + **4** + **AWAY**

Setting STAY Mode 2 Zones





4

This function allows the installer to select which zones are to be automatically isolated when the system is armed in STAY Mode 2.

Every time the system is armed in STAY Mode 2, the zones selected using this function will be automatically isolated.

To arm the system in STAY Mode 2, hold down the  button until two beeps are heard. Refer to Hold Down Functions on page 93 or Arming The System In STAY Mode 2 on page 45 for more information.





How To Set STAY Mode 2 Zones

1. Enter your  followed by 4 and the  button.
Three beeps will be heard and the STAY indicator will begin to flash.
2. * Enter the  that you wish to automatically isolate followed by the  button.
The corresponding ZONE indicator will begin to flash to display that you have selected that zone to be automatically isolated every time you arm the system in STAY Mode 2.

If more than one zone is required to be automatically isolated in STAY Mode 2, repeat step 2 until all zones required have been selected.

3. Press the  button to exit this function.
Two beeps will be heard and the system will return to the disarmed state. The zones that were selected to be automatically isolated in STAY Mode 2 and the STAY indicator will extinguish.



 + 4 + 
+  +  + 

-
- * As each zone has been selected to be isolated, the corresponding ZONE indicator will begin to flash. If a mistake has been made, press the zone number that was incorrectly entered followed by the  button. This zone is now no longer programmed to be isolated and the ZONE indicator will extinguish.







This function will not operate on Solution Ultima 880 control panels that have been partitioned.

Example

If you wish to select zones 2, 5 and 6 to be automatically isolated when arming in STAY Mode 2, follow the sequence below.



1 2 3 4 + 4 + 
+ 2 +  + 5 +  + 6 +  + 

How To Disable STAY Mode 2 Zones

If at any time you wish to disable all zones selected to be automatically isolated for STAY Mode 2, you may enter the following sequence.



INSTALLER CODE + 4 + **AWAY**
+ **AWAY**

Satellite Siren Service Mode

5

If an EDMSAT is connected to Output 1, this function will allow you to perform service work on the system without triggering the satellite siren. The satellite siren will return to its normal working state the next time the system is armed.

How To Enter Satellite Siren Service Mode

1. Enter your **INSTALLER CODE** followed by 5 and the **AWAY** button. Three beeps will be heard.



INSTALLER CODE + 5 + **AWAY**

Turning Telephone Monitor Mode On/Off

6

Telephone monitor mode allows the remote codepad to be used for a visual representation of data transmissions between the control panel and the base station receiver. The dialling sequence is also shown in this mode.

The codepad will beep once every two seconds while telephone monitor mode is active regardless of whether the system is in Installer's Programming Mode or normal operating mode. The first five indicators are used to display the progressive steps for a transmission to the base station receiver.

After you enter telephone monitor mode, hold down button 9 until two beeps are heard to initiate a test report.

Zone Indicator	Dialling Event
1	Telephone Line Seized
2	Dialling Phone Number
3	Handshake Received
4	Data Is Being Sent
5	Kiss-Off Received
None	Telephone Line Released

Table 33: Telephone Monitor Mode Indications

How To Turn Telephone Monitor Mode On

1. Enter your followed by 6 and the button. Three beeps will be heard.
2. Hold down button 9 until two beeps are heard to initiate a test report.

How To Turn Telephone Monitor Mode Off

1. Enter your followed by 6 and the button. Two beeps will be heard.



+ 6 +

Walk Test Mode

7

Walk test mode allows you to test detection devices to ensure that they are functioning correctly. Before activating walk test mode, isolate any zones that are not required for testing. Refer to Isolating Zones on page 48 for further information. Refer to LOCATION 327 - 328 on page 184 to program walk test mode reports.

How To Enter Walk Test Mode

1. Enter your **INSTALLER CODE** followed by **7** and the **AWAY** button.
Three beeps will be heard and the STAY and AWAY indicators will begin to flash. The codepad will beep once every second while the system is in walk test mode.
2. Unseal and seal the zones to be tested.
The codepad will sound one long beep and the horn speaker will sound one short beep every time a zone is sealed or unsealed.
3. Press the **AWAY** button to exit this function.
Two beeps will be heard and the STAY and AWAY indicators will extinguish. The system has now returned to the disarmed state.



INSTALLER CODE + **7** + **AWAY**

Event Memory Recall Mode

8

This function allows you to playback the last forty events that have occurred to the system. The event memory recall mode reports all alarms and arming/disarming of the system in the AWAY Mode, STAY Mode 1 and STAY Mode 2. This function helps with trouble shooting system faults. The events are displayed via the codepad indicators.

How To Enter The Event Memory Recall Mode

1. Enter your **INSTALLER CODE** followed by **8** and the **AWAY** button. Three beeps will be heard. The events will be played back via the codepad indicators in reverse chronological order.



INSTALLER CODE + **8** + **AWAY**

Example

If the events were as follows:

Event No	Event Description
1	System Armed In AWAY Mode
2	Alarm In Zone 3
3	Alarm In Zone 4
4	System Disarmed

Table 34: Event Memory Recall - Example Events

The event memory playback will report as follows:

Event No	Codepad Indicator	Event Description
4	All Indicators Off Except MAINS	System Disarmed
3	Zone 4 + AWAY Indicator Illuminates	Alarm In Zone 4
2	Zone 3 + AWAY Indicator Illuminates	Alarm In Zone 3
1	AWAY Indicator Illuminates	System Armed In AWAY Mode

Table 35: Event Memory Recall - Example Event Playback

A beep and an illuminated indicator indicate each event. Resetting a 24-hour alarm in the disarmed state is indicated by one beep only. After the last event, three beeps will be heard to indicate the end of playback. The replay of event memory can be terminated at any time by pressing the **AWAY** button.



If the system is armed in STAY Mode 1 or STAY Mode 2, the STAY indicator will display during the event memory playback. There is no differentiation between arming the system in STAY Mode 1 and STAY Mode 2.

If the control panel has been powered down, the memory of all events will be lost.

All Solution Ultima 880 control panels that have been partitioned will only replay the last ten events for each area.

Master Code Functions

Master Code Functions are designed to allow those users that have the appropriate priority level to perform certain functions of a supervisory level. These functions can only be carried out when the system is in the disarmed state.



The default Master Code is 2580 and is known as User Code 1. It is possible for the system to have multiple Master Codes. Refer to "User Code Priority" on page 161 for more information.

To enter the required Master Code function, enter the [MASTER CODE] followed by the required [FUNCTION] digit and the [AWAY] button. All available Master Code functions are listed in "Table 36: Master Code Functions" outlined below.



Function	Description	Page
0	Arm Or Disarm Both Areas At The Same Time	76
1	Changing and Deleting User Codes/Radio Codes	77/79
2	Changing Domestic Phone Numbers	81
3	Changing Telco Arm/Disarm Sequence	83
4	Setting STAY Mode 2 Zones	86
5	Turning Outputs On/Off	87
6	Setting The Date and Time	89
7	Walk Test Mode	90
8	Event Memory Recall Mode	91

Table 36: Master Code Functions

Arm or Disarm Both Areas At The Same Time

0

This Master Code function only operates on Solution Ultima 880 systems that have been partitioned. The Master Code function allows those Master Code user codes that are allocated to both Area 1 and Area 2 to arm or disarm both areas at the same time.

This allows the user to ensure that both areas will be armed or disarmed by pressing one extra button rather than entering a code twice to ensure both areas are armed or disarmed. This function can be used to arm both areas at the same time from either the CP5 Area Addressable Codepad (CP500A) or the Master Partitioned Codepad (CP500P). Refer to Option 2 in "LOCATION 445" on page 242 to enable this feature.

How To Arm/Disarm Both Areas At The Same Time

1. Enter your [MASTER CODE] followed by 0 and the [AWAY] button. Two beeps will be heard and both areas will be armed or disarmed from AWAY Mode.



Changing and Deleting User Codes

1

This function allows a Master Code holder to add/change or delete any of the system user codes. When using a *Solution Ultima 880* control panel that has been partitioned, user codes cannot be added, changed or deleted by the Master Code holder unless they (the user code) have been allocated to an area or the same area as the Master Code. Refer to User Code Allocations on page 245 for more information

How To Add Or Change A User Code

1. Enter your **MASTER CODE** followed by **1** and the **AWAY** button.
Three beeps will be heard and the STAY and AWAY indicators will begin to flash.
2. Enter the **USER NUMBER** (1-8) that you wish to change followed by the **AWAY** button.
Two beeps will be heard and the corresponding ZONE indicator will illuminate. Refer to "Table 37: Codepad Indicators Showing Relative User Numbers" on page 78.
3. Enter the digits required for the **NEW CODE** followed by the **AWAY** button.
Two beeps will be heard and the STAY and AWAY indicators will extinguish.

If you wish to add or change additional user codes, repeat this procedure as many times as required.



MASTER CODE + **1** + **AWAY**
 + **USER NUMBER** + **AWAY** + **NEW CODE** + **AWAY**



When adding or changing user codes, this function will automatically terminate if a button is not pressed within sixty seconds or by pressing the **AWAY button. One long beep indicates the code entered already exists or an incorrect user number has been selected.**

Example

If you wish to program user code number 2 as 4627, follow the steps outlined below and remember to substitute the default Master Code (2580) with the Master Code that has been programmed.



2580 + **1** + **AWAY**
 + **2** + **AWAY**
 + 4627 + **AWAY**

How To Delete A User Code

1. Enter your **MASTER CODE** followed by **1** and the **AWAY** button.
Three beeps will be heard and the STAY and AWAY indicators will begin to flash.
2. Enter the **USER NUMBER** (1-8) that you wish to delete followed by the **AWAY** button.
Two beeps will be heard and the corresponding ZONE indicator will illuminate. Refer to "Table 37: Codepad Indicators Showing Relative User Numbers" on page 78.
3. Press the **STAY** button to delete the user code.
Two beeps will be heard and the STAY and AWAY indicators will extinguish.

If you wish to delete additional user codes, repeat this procedure as many times as required.

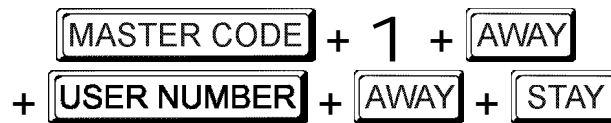

When deleting user codes, this function will automatically terminate if a button is not pressed within sixty seconds or by pressing the **AWAY** button. One long beep indicates an incorrect user number has been selected.

User No	Zone 1 Indicator	Zone 2 Indicator	Zone 3 Indicator	Zone 4 Indicator	Zone 5 Indicator	Zone 6 Indicator	Zone 7 Indicator	Zone 8 Indicator
1	✓							
2		✓						
3			✓					
4				✓				
5					✓			
6						✓		
7							✓	
8								✓

Table 37: Codepad Indicators Showing Relative User Numbers

Example

If you wish to delete user code number 3, follow the steps outlined below and remember to substitute the default Master Code (2580) with the Master Code that has been programmed.

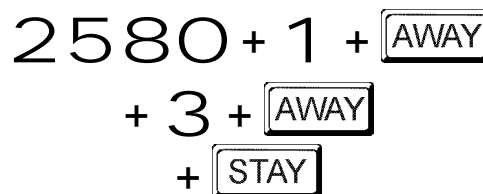

Changing and Deleting Remote Radio User Codes

1

This function allows a Master Code holder to add/change or delete any of the system user codes.

How To Add Or Change A Remote Radio User Code

1. Enter your **MASTER CODE** followed by **1** and the **AWAY** button.
Three beeps will be heard and the STAY and AWAY indicators will begin to flash.
2. Enter the **USER NUMBER** (9-16) that you wish to change followed by the **AWAY** button.
Two beeps will be heard and the corresponding codepad indicators will illuminate. Refer to "Table 38: Codepad Indicators Showing Relative Remote User Numbers" on page 80.
3. Enter the **RF 9-Digit ID No** found on the back of the radio remote hand held Transmitter followed by the # button. Two beeps will be heard and the STAY and AWAY indicators will extinguish.

If you wish to add additional remote radio user codes, repeat this procedure as many times as required.



MASTER CODE + **1** + **AWAY**
 + **USER NUMBER** + **AWAY** + **RF 9-Digit ID No**



When adding or changing remote radio user codes, this function will automatically terminate if a button is not pressed within sixty seconds or by pressing the **AWAY button will also terminate the session at anytime. One long beep indicates the code entered already exists or an incorrect user number has been selected.**

How To Delete A Remote Radio User Code

1. Enter your **MASTER CODE** followed by **1** and the **AWAY** button.
Three beeps will be heard and the STAY and AWAY indicators will begin to flash.
2. Enter the **USER NUMBER** (9-16) that you wish to delete followed by the **AWAY** button.
Two beeps will be heard and the corresponding ZONE indicator will illuminate. Refer to "Table 38: Codepad Indicators Showing Relative Remote User Numbers" on page 80.
3. Press the **STAY** button to delete the user code.
Two beeps will be heard and the STAY and AWAY indicators will extinguish.

If you wish to delete additional remote radio user codes, repeat this procedure as many times as required.

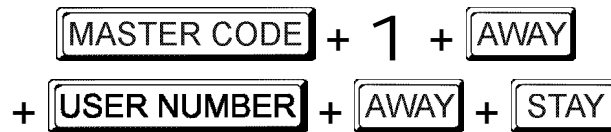

When deleting remote radio user codes, this function will automatically terminate if a button is not pressed within sixty seconds or by pressing the **AWAY** button will also terminate the session at anytime. One long beep indicates the an incorrect user number has been selected.



User No	Zone 1 Indicator	Zone 2 Indicator	Zone 3 Indicator	Zone 4 Indicator	Zone 5 Indicator	Zone 6 Indicator	Zone 7 Indicator	Zone 8 Indicator	MAINS Indicator
9	✓							✓	
10									✓
11	✓								✓
12		✓							✓
13			✓						✓
14				✓					✓
15					✓				✓
16						✓			✓

Table 38: Codepad Indicators Showing Relative Remote User Numbers

Changing Domestic Phone Numbers

2

When the system has been set up for domestic dialling, this function allows the Master Code holder to view and program the required telephone numbers that the system will call in the event of an alarm. For a more detailed description, refer to Domestic Dialling on page 125 for further information.

How To Change Domestic Phone Numbers

1. Enter your **MASTER CODE** followed by **2** and the **AWAY** button.
Three beeps will be heard and the STAY and AWAY indicators will begin to flash.

If there are telephone numbers already programmed, they will be displayed one digit at a time via the remote codepad indicators. Refer to "Table 40: Codepad Indicators When Changing Domestic Telephone Numbers" on page 82 for the indicators and their meanings.

If there are no telephone numbers programmed, a further two beeps will be heard after entering this mode. These two beeps are normally heard after the last digit of the last phone number has been displayed.
2. Enter all the digits for **PHONE No 1**, one digit at a time. You will notice as each digit is entered, the corresponding codepad indicators will illuminate.
3. If there is more than one telephone number, press the **STAY** button followed by the **4** button after the last digit of the telephone number. This will insert a break between the first telephone number and the second telephone number. If there is only one phone number, press the **AWAY** button to exit this mode.
4. Enter all the digits for **PHONE No. 2**, one digit at a time. You will notice as each digit is entered, the corresponding codepad indicators will illuminate.
5. After the last digit of the second telephone number, press the **AWAY** button to exit this mode unless a third telephone number is required. If there is a third telephone number to be programmed, press the **STAY** button followed by the **4** button to insert a break between the second telephone number and the third telephone.



MASTER CODE + **2** + **AWAY**
 + **PHONE No 1** + **STAY** + **4** + **PHONE No. 2** + **AWAY**

Digit Required	Number To Program	Digit Required	Number To Program
0	0	8	8
1	1	9	9
2	2		
3	3	*	STAY Followed By 1
4	4	#	STAY Followed By 2
5	5	Four Second Pause	STAY Followed By 3
6	6	Break	STAY Followed By 4
7	7	15	STAY Followed By 5

Table 39: Domestic Dialling Digits

Example

If you wish to program two separate telephone numbers (9672 1777 and 9672 1233), follow the sequence below and replace the telephone numbers mentioned in the manual with the telephone numbers that you wish to program. Remember to substitute the default Master Code (2580) with the Master Code that has been programmed.



2580 + 2 + AWAY
 + 96721777 + STAY + 4
 + 96721233 + AWAY

How To Disable Domestic Dialling

If at any time you wish to cancel domestic dialling for any reason (e.g.. You are moving house and do not wish the system to continue calling your work place or mobile phone etc), you may enter the following sequence.



MASTER CODE + 2 + AWAY + STAY + 4 + AWAY

Digit	Zone 1 Indicator	Zone 2 Indicator	Zone 3 Indicator	Zone 4 Indicator	Zone 5 Indicator	Zone 6 Indicator	Zone 7 Indicator	Zone 8 Indicator	MAINS Indicator
0									✓
1	✓								
2		✓							
3			✓						
4				✓					
5					✓				
6						✓			
7							✓		
8								✓	
9	✓							✓	
*	✓								✓
#		✓							✓
Pause			✓						✓
Break				✓					✓

Table 40: Codepad Indicators When Changing Domestic Telephone Numbers

3 *Change Telco Arm/Disarm Sequence*

This feature allows you to program the Telco Arm Sequence (Option 1) and Telco Disarm Sequence (Option 2). This feature is only available if your telecommunication provider has the call forward option available

Option 1 – Telco Arm Sequence

This allows you to program the Call Forward – Immediate On sequence or Call Forward – No Answer sequence that will automatically operate when you arm the system in AWAY mode.

Note: The examples given in this feature are only applicable to Australia.

Call Forward – Immediate On

You can redirect calls to anywhere in Australia, including mobiles, pagers and answering services. When Call Forward – Immediate On is turned on, your telephone will not ring.

Call Forward – No Answer

When your telephone is not answered within 20 seconds, this feature redirects all incoming calls to another number anywhere in Australia.

Option 2 – Telco Disarm Sequence

This allows you to automatically disable the call forward sequence upon disarming the system.

Contact your telecommunications provider for more information on Call Forward operations.

<i>Digit Required</i>	<i>Number To Program</i>	<i>Digit Required</i>	<i>Number To Program</i>
0	0	8	8
1	1	9	9
2	2		
3	3	*	<input type="button" value="STAY"/> Followed By 1
4	4	#	<input type="button" value="STAY"/> Followed By 2
5	5	Four Second Pause	<input type="button" value="STAY"/> Followed By 3
6	6	Break	<input type="button" value="STAY"/> Followed By 4
7	7	15	<input type="button" value="STAY"/> Followed By 5

Table 41: Telco Arm/Disarm Dialling Digits

How To Program Telco Arming Sequence

1. Enter your **MASTER CODE** followed by **3** and the **AWAY** button.
Three beeps will be heard and the STAY and AWAY indicators will begin to flash.
2. Press button **1** followed by the **AWAY** button to change the telco arm sequence. Three beeps will be heard.

If a previous call forwarding sequence has already been programmed, the sequence will be displayed one digit at a time via the remote codepad indicators.

If there is no call forward sequence programmed, a further two beeps will be heard after entering this mode. These two beeps are normally heard after the last digit of the call forward sequence has been displayed.

3. Enter the call forward sequence that you require (e.g.: ***61 Phone Number #** if you wish to program the Call Forward – No Answer sequence or ***21 Phone Number #** if you wish to program the Call Forward – Immediate sequence).

Remember that when you program a * in the telco arm sequence, you enter *1 and when you program the # in the telco arm sequence, you enter *2.

4. Press the **AWAY** button when finished. Two beeps will be heard and the system will return to the disarmed state.



MASTER CODE + **3** + **AWAY**
1 + **AWAY**
STAY 1 6 1 + **PHONE N°** + **STAY 2** + **AWAY**

Example

If you wish to automatically divert all unanswered incoming calls to another telephone number (e.g.: 9672 1777) when the system is armed in AWAY Mode, follow the example sequence below and replace the telephone number mentioned in the manual with the telephone number that you wish to divert all calls to. Remember to substitute the default Master Code (2580) with the Master Code that has been programmed.



2580 + **3** + **AWAY**
1 + **AWAY** + **STAY 1 6 1** + **96721777**
STAY 2 + **AWAY**

How To Disable The Telco Arm Sequence

If at any time you wish to cancel the telco arming sequence, you may enter the following sequence.



MASTER CODE + **3** + **AWAY** + **1** + **AWAY**
STAY + **4** + **AWAY**

How To Program The Telco Disarm Sequence

1. Enter your **MASTER CODE** followed by **3** and the **AWAY** button. Three beeps will be heard and the STAY and AWAY indicators will begin to flash.
2. Press button **2** followed by the **AWAY** button to change the telco disarm sequence. Three beeps will be heard.

If a previous telco disarming sequence has already been programmed, the sequence will be displayed one digit at a time via the remote codepad indicators.

If no telco disarming sequence has been programmed, a further two beeps will be heard after entering this mode. These two beeps are normally heard after the last digit of the call forward sequence has been displayed.

3. Enter the call forward disable sequence that you require (e.g.: **#61#** if you wish to disable the Call Forward – No Answer sequence, or **#21#** if you wish to disable the Call Forward – Immediate On sequence.

Remember that when you program the # in the telco disarm sequence, you enter *2.

4. Press the # button when finished. Two beeps will be heard and the system will return to the disarmed state.



MASTER CODE + **3** + **AWAY**
2 + **AWAY**
STAY **261** **STAY** **2** + **AWAY**

How To Disable The Telco Disarm Sequence

If at any time you wish to cancel the telco disarm sequence, you may enter the following sequence.



MASTER CODE + **3** + **AWAY** + **2** + **AWAY**
+ **STAY** + **4** + **AWAY**





Setting STAY Mode 2 Zones

4

This function allows the Master Code Holder to select which zones are to be automatically isolated when the system is armed in STAY Mode 2. Every time the system is armed in STAY Mode 2, the zones selected using this function will be automatically isolated.

To arm the system in STAY Mode 2, hold down the  button until two beeps are heard. Refer to Hold Down Functions on page 93 or Arming The System In STAY Mode 2 on page 45 for more information.





How To Set STAY Mode 2 Zones

1. Enter your  followed by 4 and the  button.
Three beeps will be heard and the STAY indicator will begin to flash.
2. * Enter the  that you wish to automatically isolate followed by the  button.
The corresponding ZONE indicator will begin to flash to display that you have selected that zone to be automatically isolated every time you arm the system in STAY Mode 2.

If more than one zone is required to be automatically isolated in STAY Mode 2, repeat step 2 until all zones required have been selected.

3. Press the  button to exit this function.
Two beeps will be heard and the system will return to the disarmed state. The zones that were selected to be automatically isolated in STAY Mode 2 and the STAY indicator will extinguish.



 + 4 + 
 +  +  + 







- * As each zone has been selected to be isolated, the corresponding ZONE indicator will begin to flash. If a mistake has been made, press the zone number that was incorrectly entered followed by the  button. This zone is now no longer programmed to be isolated and the ZONE indicator will extinguish.

This function will not operate on Solution Ultima 880 control panels that have been partitioned.

Example

If you wish to select zones 2, 5 and 6 to be automatically isolated when arming in STAY Mode 2, follow the sequence below. Remember to substitute the default Master Code (2580) with the Master Code that has been programmed.



2580 + 4 + 
 + 2 +  + 5 +  + 6 +  + 

How To Disable STAY Mode 2 Zones

If at any time you wish to disable all zones selected to be automatically isolated for STAY Mode 2, you may enter the following sequence.



MASTER CODE + 4 + AWAY
 + AWAY

Turning Outputs On/Off

5

If an output has been programmed for remote operation, you can turn the remote output on or off using this Master Code function or remotely using the Alarm Link Software.

For this Master Code Function to operate, one or more programmable outputs will need to be programmed with one of the following output event types.

Output Number 1 = Output Event Type – 2,8 on page 207.

Output Number 2 = Output Event Type – 2,9 on page 207.

Output Number 3 = Output Event Type – 2,10 on page 207.

How To Turn An Output On From The Remote Codepad

1. Enter your MASTER CODE followed by 5 and the AWAY button.
Three beeps will be heard and the STAY and AWAY indicators will begin to flash.
2. Enter the required OUTPUT No. (1-3) followed by the AWAY button.
Three beeps will be heard and the output will now turn on. Repeat step 2 if more than one output is required to be turned on.
3. Press the AWAY button again to exit this function.
Two beeps will be heard and the STAY and AWAY indicators will extinguish.



MASTER CODE + 5 + AWAY
 + OUTPUT No. + AWAY + AWAY

Example

If Output 2 has been programmed as 281 000 in “LOCATION 386 – 391”, the Master Code holder may turn on this output following the steps outlined below;



2580 + 5 + AWAY
 + 1 + AWAY + AWAY

How To Turn An Output Off From The Remote Codepad

1. Enter your **MASTER CODE** followed by **5** and the **AWAY** button.
Three beeps will be heard and the STAY and AWAY indicators will begin to flash.
2. Enter the required **OUTPUT No.** (1-3) followed by the **STAY** button.
Two beeps will be heard and the output will now turn off. Repeat step 2 if more than one output is required to be turned off.
3. Press the **AWAY** button again to exit this function.
Two beeps will be heard and the STAY and AWAY indicators will extinguish.



MASTER CODE + **5** + **AWAY**
 + **OUTPUT No.** + **STAY** + **AWAY**

Example

If Output 2 has been programmed as **281000** in “LOCATION 386 – 391”, the Master Code holder may turn off this output following the steps outlined below;



2580 + **5** + **AWAY**
 + **1** + **STAY** + **AWAY**

Setting The Date and Time

6

This function only needs to be used when the date and time requires to be changed or the system has been powered down.

If the date and time has not been set using this function, the date and time fault will only display when the Auto Arming Time in "LOCATION 426 - 429" on page 220 has been programmed, or when you enter Fault Analysis Mode by holding down the **5** button.

How To Set The New Date and Time

1. Enter your **MASTER CODE** followed by **6** and the **AWAY** button.
Three beeps will be heard and the STAY and AWAY indicators will begin to flash.
2. Enter the day, month, year, hour and minute using the (DD, MM, YY, HH, MM) format (i.e.. DD = Day of the month, MM = Month of the year, YY = Current year, HH = Hour of the day, MM = Minute of the day).
Please note that when programming the hour of the day, you will need to use 24:00 hour format.
3. Press the **AWAY** button when finished.
Two beeps will be heard and the STAY and AWAY indicators will extinguish. If a long beep is heard, an error was made when entering the date and time.



$$\boxed{\text{MASTER CODE}} + 6 + \boxed{\text{AWAY}}$$

$$\text{DD} + \text{MM} + \text{YY} + \text{HH} + \text{MM}$$

$$+ \boxed{\text{AWAY}}$$

Example

If the date and time needs to be set for the 1st February 1997 at 10:30 PM, program the date and time as follows;



$$2580 + 6 + \boxed{\text{AWAY}}$$

$$01 + 02 + 97 + 22 + 30$$

$$+ \boxed{\text{AWAY}}$$

Walk Test Mode

7

Walk test mode allows you to test detection devices to ensure that they are functioning correctly. Before activating walk test mode, isolate any zones that are not required for testing. Refer to Isolating Zones on page 48 for further information. Refer to “LOCATION 327 - 328” on page 184 to program walk test mode reports.

How To Enter Walk Test Mode

1. Enter your **MASTER CODE** followed by **7** and the **AWAY** button.
Three beeps will be heard and the STAY and AWAY indicators will begin to flash. The codepad will beep once every second while the system is in walk test mode.
2. Unseal and seal the zones to be tested.
The codepad will sound one long beep and the horn speaker will sound one short beep every time a zone is sealed or unsealed.
3. Press the **AWAY** button to exit this function.
Two beeps will be heard and the STAY and AWAY indicators will extinguish. The system has now returned to the disarmed state.



MASTER CODE + **7** + **AWAY**

Event Memory Recall Mode

8

This function allows you to playback the last forty events that have occurred to the system. The event memory recall mode reports all alarms and arming/disarming of the system in the AWAY Mode, STAY Mode 1 and STAY Mode 2. This function helps with trouble shooting system faults. The events are displayed via the codepad indicators.

How To Enter The Event Memory Recall Mode

1. Enter your **MASTER CODE** followed by **8** and the **AWAY** button. Three beeps will be heard. The events will be played back via the codepad indicators in reverse chronological order.



MASTER CODE + **8** + **AWAY**

Example

If the events were as follows:

Event No	Event Description
1	System Armed In AWAY Mode
2	Alarm In Zone 3
3	Alarm In Zone 4
4	System Disarmed

Table 42: Event Memory Recall - Example Events

The event memory playback will report as follows:

Event No	Codepad Indicator	Event Description
4	All Indicators Off Except MAINS	System Disarmed
3	Zone 4 + AWAY Indicator Illuminates	Alarm In Zone 4
2	Zone 3 + AWAY Indicator Illuminates	Alarm In Zone 3
1	AWAY Indicator Illuminates	System Armed In AWAY Mode

Table 43: Event Memory Recall - Example Event Playback

A beep and an illuminated codepad indicator indicate each event. Resetting a 24-hour alarm in the disarmed state is indicated by one beep only. After the last event, three beeps will be heard to indicate the end of playback. The replay of event memory can be terminated at any time by pressing the **AWAY** button.



If the system is armed in STAY Mode 1 or STAY Mode 2, the STAY indicator will display during the event memory playback. There is no differentiation between arming the system in STAY Mode 1 and STAY Mode 2.

If the control panel has been powered down, the memory of all events will be lost.

All Solution Ultima 880 control panels that have been partitioned will only replay the last ten events for each area.

User Code Functions



Function	Description
0	Arm Or Disarm Both Areas At The Same Time (CC488)

Table 44: User Code Functions

Arm or Disarm Both Areas At The Same Time

0

This user code function only operates on *Solution Ultima 880* systems that have been partitioned. The function allows those user codes that are allocated to both Area 1 and Area 2 to arm or disarm both areas at the same time.

This allows the user to ensure that both areas will be armed or disarmed by pressing one extra button rather than entering a code twice to ensure both areas are armed or disarmed. This function can be used to arm both areas at the same time from either the CP5 Area Addressable Codepad (CP500A) or the Master Partitioned Codepad (CP500P). Refer to Option 2 in "LOCATION 445" on page 242 to enable this feature.

How To Arm/Disarm Both Areas At The Same Time

1. Enter your **USER CODE** followed by **0** and the **AWAY** button.
Two beeps will be heard and both areas will be armed or disarmed from AWAY Mode.



Hold Down Functions

Hold down functions have been incorporated to allow easy activation of specific operations. When a button is held down for two seconds, two beeps will be heard and a particular function will operate. The hold down functions available are listed below.

Arm The System In AWAY Mode

#

Holding the # button down until two beeps are heard will arm the system in AWAY Mode. Option 2 in "LOCATION 441" on page 232 will need to be enabled for this hold down function to operate.



This hold down function will not operate on *Solution Ultima 880* control panels when partitioned using the CP5 Master Partitioned codepad (CP500P). Holding the # button down until two beeps are heard on a CP5 Area Addressable codepad (CP500A) will arm the corresponding area in AWAY Mode.

Arm The System In STAY Mode 1

*

Holding the * button down until two beeps are heard will arm the system in STAY Mode 1. Option 2 in "LOCATION 441" on page 232 will need to be enabled for this hold down function to operate.

If there has not been an alarm during the armed cycle, holding the * button down a second time will disarm the system from STAY Mode 1. If you require single button disarming from STAY Mode 1 using this hold down function, Option 4 in "LOCATION 441" on page 232 will need to be enabled.

If an alarm has occurred or entry warning has triggered, a valid user code will need to be used to disarm the system.

Refer to Zone Options 2 on page 179 for information on programming each zone to be automatically isolated in STAY Mode 1.



This hold down function will not operate on *Solution Ultima 880* control panels when partitioned using the CP5 Master Partitioned codepad (CP500P). Holding the * button down until two beeps are heard on a CP5 Area Addressable codepad (CP500A) will arm the corresponding area in STAY Mode 1.

Arm The System In STAY Mode 2

- Holding the ○ button down until two beeps are heard will arm the system in STAY Mode 2. Option 2 in "LOCATION 441" on page 232 will need to be enabled for this function to operate.

If there has not been an alarm during the armed cycle, holding the ○ button down a second time will disarm the system from STAY Mode 2. If you require single button disarming from STAY Mode 2 using this hold down function, Option 4 in "LOCATION 441" on page 232 will need to be enabled.

If an alarm has occurred or entry warning has been triggered, a valid user code will need to be used to disarm the system.

Refer to Setting STAY Mode 2 Zones using the Installer Code function on page 71 or Setting STAY Mode 2 Zones using the Master Code function on page 86 for more information.



STAY Mode 2 is not available to Solution Ultima 880 control panels that have been partitioned.

Horn Speaker Test

- 1 Holding the 1 button down until two beeps are heard will sound the horn speaker for a two-second burst. No other sounding device will sound in this mode.

Bell Test

- 2 Holding the 2 button down until two beeps are heard will sound the internal screamers for a two-second burst. No other sounding device will sound in this mode.

If an EDMSAT (SS914) has been connected to the control panel, this function will test both the horn speaker and the strobe connected to the satellite siren for two seconds.

Strobe Test

- 3 Holding the 3 button down will operate the strobe. No other device will operate in this mode.

If an EDMSAT (SS914) has been connected to the control panel, this function will also test the strobe on the satellite siren.

How To Turn Strobe Test ON

1. Hold down the 3 button until three beeps are heard. The strobe will begin to flash.

How To Turn Strobe Test OFF

1. Hold down the 3 button until two beeps are heard. The strobe will stop flashing.

Turning Day Alarm On and Off

4

Holding the 4 button down will turn day alarm on or off. If the STAY indicator is required to indicate the status of day alarm operation (enabled/disabled), refer to Option 8 in "LOCATION 440" on page 231 for further information. The STAY indicator when enabled, will flash once every 3 seconds to display when day alarm is active.

How To Turn Day Alarm ON

1. Hold down the 4 button until three beeps are heard.
Day alarm has now been turned on.

How To Turn Day Alarm OFF

1. Hold down the 4 button until two beeps are heard.
Day alarm has now been turned off.

Fault Analysis Mode

5

There are various system faults that can be detected by the control panel. When any of these faults are present, the FAULT indicator will begin to flash and the codepad will beep once every minute. Refer to Fault Descriptions on page 53 for a more detailed description on each fault type.

How To Determine The Type Of Fault

1. Hold the 5 button down until two beeps are heard.
The STAY and AWAY indicators will begin to flash in unison with the FAULT indicator. One or more ZONE indicators (1-8) will illuminate to indicate the type of fault that has occurred.

How To Exit Fault Analysis Mode

1. To exit fault analysis mode, press the  button.
The STAY and AWAY indicators will extinguish and return you to the disarmed state.

<i>Zone Indicator</i>	<i>Fault Description</i>	<i>Hold Down Button</i>	<i>Zone Indicator</i>	<i>Fault Condition</i>
1	System Fault	1	1	Low Battery
			2	Date & Time
			3	RF Receiver Jamming
				RF Receiver Tamper Switch
				RF Receiver Comms Failure
			4	Horn Speaker
			5	Telephone Line Fail
			6	E2 Fault
			7	Fuse Fail
2	RF Low Battery	2	1 - 8	Zones 1 - 8 RF Low Battery
3	Zone Tamper Alarm	3	1 - 8	Zones 1 - 8 Tamper Alarm
4	Sensor Watch Fault	4	1 - 8	Zones 1 – 8 Sensor Watch Fail
5	RF Sensor Watch	5	1 – 8	Zones 1 - 8 RF Sensor Watch Fail
6	Communication Fail	6	1	Receiver 1 Fail
			2	Receiver 2 Fail

Table 45: Fault Indicators

Initiate A Modem Call

6

Holding the **6** button down until two beeps are heard will force the control panel to dial the call back telephone number programmed in "LOCATION 159 - 174" on page 147 in an attempt to connect to the installer's remote computer.

The remote computer will be required to be running the Alarm Link Software (CC816) and will need to be set to "Waiting For An Incoming Call". If no call back telephone number has been programmed, holding down the **6** button will have no effect.

Reset Latching Outputs

7

Holding the **7** button down until two beeps are heard will reset any programmable output that has been programmed to remain on once it has been activated.

The output will need to be programmed with a latching polarity. Refer to Output Polarity on page 211 for further information.

Codepad Buzzer Tone Change

8

Holding the 8 button down continuously will change the tone of the buzzer in the remote codepad. There are fifty different tones to choose from between 1500 Hz - 5000 Hz and they are specific to each codepad. In a multiple codepad installation, each codepad can have a different tone.

How To Change The Tone Of The Buzzer

1. To change the tone of the codepad buzzer, hold the 8 button down continuously. The tone of the buzzer will start to increase in pitch.
2. Release the 8 button when the desired tone has been reached.



Every time the system has been powered down, each codepad will need their individual tone reset using this function.

How To Determine The Area That The Codepad Belongs To

When using Hold Down Function 8 on *Solution Ultima 880* control panels that have been partitioned, the codepad will indicate the area that the codepad belongs to.

1. Hold the 8 button down until two beeps are heard.
2. A ZONE indicator will illuminate to indicate which area that the codepad belongs to when the system has been partitioned.

Zone 1 = Area 1 Codepad

Zone 2 = Area 2 Codepad

Zone 7 = Master Partitioned Codepad

No ZONE indicator means that the codepad has incorrect settings or incorrect codepad used.

3. Press the  button to exit this mode.

Send Test Report

9

Holding the 9 button down until two beeps are heard will send a test report (Contact ID Event Code 602) that is used to test the dialling and reporting capabilities of the system without causing the sirens to sound.

A test report will not be sent if the Subscriber ID Number is 0000. This feature is only applicable if the control panel has been programmed to report via the telephone.

Remote System Operations Via Telephone

This section includes the following:

- *Remote Arming Via The Telephone*

Remote Arming Via The Telephone

This feature allows you to arm your system from any remote location via the telephone line. For obvious security reasons, the system cannot be disarmed using this method. To make use of this feature, you will require a touch tone telephone or the Phone Controller (CC911).

How To Remotely Arm Your System Via The Telephone

1. Call the telephone number that your control panel has been connected to.
2. When the control panel answers the incoming call, a short jingle will be heard. Hold the phone controller to the mouthpiece of the telephone and press the button on the side of the unit for 3 seconds. You can alternatively press the * button on the touch tone telephone for 3 seconds to arm the system.

If you hear a number of strange sounding tones (modem tones) when the control panel answers the incoming call, this means that the system has been programmed for remote programming functions. Simply wait for a pause in the tones and follow step 2 to remotely arm the system.

3. After releasing the button on the phone controller or the * button on the touch tone telephone, two beeps will be heard to indicate that the system has armed in AWAY Mode.
4. Hang up the telephone and the system will remain armed.

If the control panel does not answer the call, this means that the system may already be armed, remote functions have not been enabled or the ring count has been set to zero. Refer to Option 2 in "LOCATION 177" on page 153 to enable remote arming via the telephone and "LOCATION 175" on page 148 to set the number of rings before the control panel will answer.



Where both remote arming and Upload/Download via the Installer's remote computer have been selected, the control panel will answer the call expecting the remote computer. This is easily noticed, as the modem negotiating tones will be heard rather than the remote arming jingle.

If you attempt to arm a Solution Ultima 880 control panel that has been partitioned, both areas will arm in AWAY Mode. Arming individual areas is not available using this method.

Programming

This section includes the following:

- *Programming*
- *Programming With The Remote Codepad*
- *Programming With The Hand Held Programmer*
- *Programming With The Programming Key*
- *Programming Option Bits*
- *Installer's Programming Commands*
- *Disable Factory Default*
- *Defaulting The Control Panel*

Programming

The programming options of the control panel are stored in a non-volatile EPROM. This memory will hold all the relevant configuration and user specific data even during a total power loss.

The data retention time is as long as ten years without power; therefore, no reprogramming will be required after powering the control panel down.

The data can be changed as many times as required without the need for any additional specialised equipment. This memory is laid out in numerous locations, each of which holds the data for a specific function.



15 is the maximum value that can be programmed into any location.

In general, the entire programming sequence will consist of nominating the required location number and then enter or change the current data. You will repeat this procedure until all the data has been programmed to suit your requirements. The factory default settings have been selected for reporting to the monitoring station in the Contact ID Format.

The Installers Code only gives access to the Installer's Programming Mode and does NOT arm and disarm the system. Installer's Programming Mode can not be entered when the system is armed, or at any time during siren run time.

Programming of the *Solution Ultima 844/862/880* control panel can be carried out via any of the following three methods.

- Remote Codepad
- Hand Held Programmer (CC814)
- Alarm Link Upload/Download Software (CC816)

Example

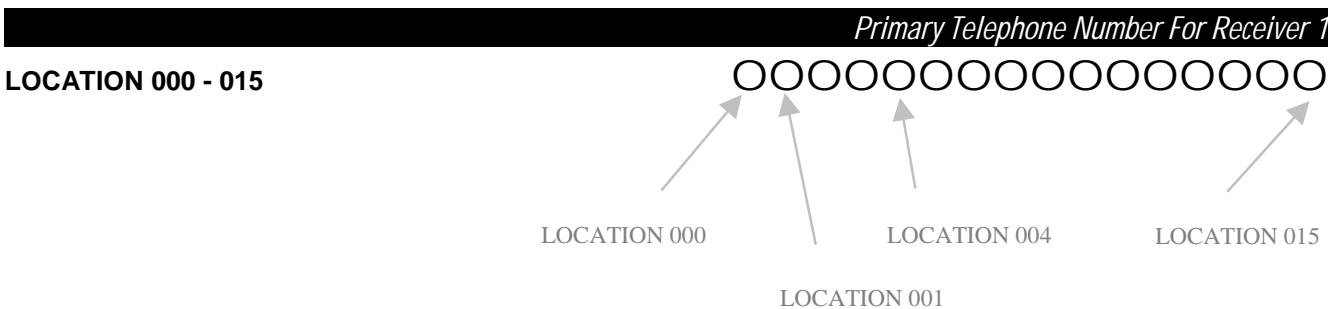

Programming With The Remote Codepad

When programming the control panel via the remote codepad, the system must be in the disarmed state with no alarm memory present.

To access the Installer’s Programming Mode, enter the four digit **INSTALLER CODE** followed by the **AWAY** button. The factory default Installer Code is **1 2 3 4**. Two beeps will be heard and both the AWAY and the STAY indicators will flash simultaneously to indicate that you have entered Installer’s Programming Mode.

When entering Installer’s Programming Mode, you will be automatically positioned at “LOCATION 000”, the beginning of the Primary Telephone Number for Receiver 1.

Data Value	Zone 1 Indicator	Zone 2 Indicator	Zone 3 Indicator	Zone 4 Indicator	Zone 5 Indicator	Zone 6 Indicator	Zone 7 Indicator	Zone 8 Indicator	MAINS Indicator
0									
1	✓								
2		✓							
3			✓						
4				✓					
5					✓				
6						✓			
7							✓		
8								✓	
9	✓							✓	
10									✓
11	✓								✓
12		✓							✓
13			✓						✓
14				✓					✓
15					✓				✓

Table 46: Codepad Indicators When Programming

Example

To access Installer’s Programming Mode, enter the **INSTALLER CODE** followed by the **AWAY** button. Two beeps will be heard and both the AWAY and the STAY indicators will flash simultaneously to indicate that you have entered Installer’s Programming Mode. The codepad indicators will display the current data stored in the first location (LOCATION 000).

To move to another programming location, enter the **LOCATION NUMBER** required followed by the **AWAY** button. The data of the new location will now be displayed (e.g.. **3 4** followed by the **AWAY** button will automatically step you to the beginning of the Subscriber ID Number for Receiver 1).

To move to the next location, press the **AWAY** button. This will step you to the next location and the data in that location will be displayed (e.g.. If you are currently positioned at “LOCATION 034”, pressing the **AWAY** button will step you to “LOCATION 035”).

If you press the **STAY** button without previously entering a location number, the system will step back one location (e.g.. If you are positioned at “LOCATION 035” and you press the **STAY** button, you will step back one location to LOCATION 034).

To change data in the current location, enter the new value (0 – 15) followed by the **STAY** button. This will store the new data into the location and still leave you positioned at the same location. You will notice that the new information programmed will be displayed on the codepad indicators (e.g.. If you enter the value **1 4** followed by the **STAY** button, both ZONE 4 and the MAINS indicator will illuminate).

To move to the next location, press the **AWAY** button. The data in the next locations data will now be displayed.

To exit the Installer's Programming Mode, enter command **960** followed by the **AWAY** button. Two beeps will be heard and the STAY and AWAY indicators will extinguish. The system will now return to the disarmed state and is now ready for use.

Refer to Installer's Programming Commands on page 107 for further information on commands that can be performed during access of Installer's Programming Mode.

Programming With The Hand Held Programmer



The Hand Held Programmer (CC814) has five, seven segment displays. The three seven segment displays on the left display the current location number and the two seven segment displays on the right display the data for the location currently being displayed.

To connect the hand held programmer, locate the socket marked PROGRAMMING KEY found at the top of the PCB (printed circuit board) next to the Auxiliary Module socket. Observe the triangular markings on the PCB and line them up with the markings on the hand held programmers connecting socket.

When the hand held programmer is correctly connected onto the printed circuit board, one beep will be heard and four centre bars on the hand held programmer will illuminate with either an 'A' or 'U' suffix to indicate the system is armed or unarmed. Only when the Installer's Programming Mode has been accessed will any numerals appear on the display.

WARNING

When connecting the hand held programmer to the control panel, make sure that the switch on the hand held programmer is in the EXT position and that no external programming key has been connected. Failing to do this may corrupt the control panel's memory. If this occurs, the control panel will need to be returned to Electronics Design and Manufacturing Pty Limited where a service fee will be charged to unlock the control panel's memory.

Example

To access the Installer's Programming Mode, enter the **INSTALLER CODE** followed by the # button. The factory default Installers Code is 1234. Two beeps will be heard and the hand held programmer will display the current data stored in "LOCATION 000".

To move to another programming location, enter the **LOCATION NUMBER** required followed by the # button. The data of the new location will now be displayed (e.g. 34 followed by the # button will automatically step you to the beginning of the Subscriber ID Number for Receiver 1).

To move to the next location, press the # button. This will step you to the next location and the data in that location will be displayed (e.g. If you are currently positioned at "LOCATION 034", pressing the # button will step you to "LOCATION 035").

If you press the * button without previously entering a location number, the system will step back one location (e.g. If you are positioned at "LOCATION 035" and you press the * button, you will step back one location to LOCATION 034).

To change data in the current location, enter the new value (0 – 15) followed by the * button. This will store the new data into the location and still leave you positioned at the same location. You will notice that the new information programmed will be displayed on the data display of the hand held programmer (e.g. If you enter the value 14 followed by the * button, the data display will display 14).

To move to the next location, press the # button. The data in the next location will now be displayed.

To exit the Installer's Programming Mode, enter command **960** followed by the **#** button. Two beeps will be heard and the system will return to the disarmed state. Refer to Installer's Programming Commands on page 107 for further information on commands that can be performed during access of the Installer's Programming Mode.



When using the hand held programmer, any reference in this manual made to the **STAY** button should be considered as the ***** button and the **AWAY** button considered as the **#** button.

Programming With The Programming Key

The Programming Key (CC891) is a unique device that will allow you to store or copy programming information from your control panel. Once the programming key has information stored in the microprocessor, the programming key may be used to easily program other existing *Solution Ultima 844/862/880* control panels with the same programming data, or be alternatively used for back up purposes of existing information.

Connecting a programming key, which has been pre-programmed directly onto the control panel in the disarmed state, will automatically initiate a data transfer from the programming key to the control panel memory.

If you have a new programming key, you should first enter the Installer's Programming Mode and program the system as required before connecting the programming key to the control panel.

To connect the programming key, locate the socket marked PROGRAMMING KEY found at the top of the PCB (printed circuit board) next to the Auxiliary Module socket. Observe the triangular markings on the printed circuit board and line them up with the markings on the programming key.

To copy the control panel's data into the programming key, access Installer's Programming Mode (e.g.: **1234** followed by the **#** button) and enter Installer's Programming Command **962** followed by the **#** button. Refer to Command 962 - Copy Control Panel Memory To Programming Key on page 111 for further information.

To exit the Installer's Programming Mode, enter command **960** followed by the **#** button. Two beeps will be heard and the system will return to the disarmed state. Before removing the programming key, wait two seconds for the activity LED to return to its normal state. The programming key will now become your standard data pattern for future programming of your control panels.

It should be noted that when entering the Installer's Programming Mode, inserting a programming key and then changing any location will cause a simultaneous update of not only the programming keys data, but also the control panel's data. Therefore, you are not able to change data in the programming key without the same location being changed in the control panel's memory.



Connecting a Programming Key (CC891) to the control panel when the programming keys memory is blank will corrupt the control panel's memory unless the Installer's Programming Mode has been entered first. If this occurs, then the control panel will need to be returned to Electronics Design and Manufacturing Pty Limited where a service fee will be charged to unlock the control panel's memory.

Programming Option Bits

When programming these locations, you will notice that there are four alternatives per location. You may select one, two, three or all of these alternatives for each location, however, only one number is required to be programmed. This number is calculated by adding the option bit numbers together.

Example

If at "LOCATION 177" you want options 1, 2 and 4, add the numbers together and the total is the number to be programmed. In this example, the number to be programmed is 7 (i.e.. $1 + 2 + 4 = 7$).

<i>Option</i>	<i>Description</i>
1	Enabled = Allow Dialler Reporting Functions Disabled = Disable All Dialler Reporting Functions
2	Enable Remote Arming Via The Telephone
4	Enable Answering Machine Bypass Only When Armed
8	Enabled = Use Bell 103 For FSK Format Disabled = CCITT V21 Format

Table 47: Example - Programming Option Bits

Installer's Programming Commands

There are ten different commands that can be used to perform various functions once the Installer's Programming Mode has been entered. To issue the command required, enter the corresponding numerical code followed by the # button (e.g.: 965# would set the system for domestic dialling for Receiver 1).

<i>Command</i>	<i>Description</i>	<i>Page</i>
958	Enable/Disable Zone Status Mode	108
959	Test Programming Key	109
960	Exit Installer's Programming Mode	110
961	Reset Control Panel Back To Factory Default Settings	110
962	Copy The Control Panel Memory To The Programming Key	111
963	Copy The Programming Key Data To The Control Panel	112
964	Erase Programming Key	113
965	Set Up Domestic Dialling Format (Receiver 1)	114
966	Enable/Disable Automatic Stepping Of Locations During Programming	115
999	This Command Displays The Control Panel's Software Version Number Or Control Panel Type	117

Table 48: Installer's Programming Commands

Command 958 - Enable/Disable Zone Status Mode

This function enables and disables the zone status display mode when using the hand held programmer. The hand held programmer will display the zones on the seven-segment display from left to right. If there is a dash illuminated on the display of the hand held programmer, the corresponding zone is unsealed and if the display is blank, the zone is sealed.

The third (or centre) display shows either the number 4 or the number 8. The number 4 constantly illuminated indicates that zones 1 - 4 are being displayed. The number 8 constantly illuminated indicates that zones 5 - 8 are being displayed.

Pressing the # button will toggle the display between the zones. This feature will prove to be very useful during installation as the hand held programmer allows you to view the status of the zones directly at the control panel, saving you time and money.

How To Enable Zone Status Mode

1. Enter Installers Programming Mode (i.e.. 1 2 3 4 followed by the # button).
Two beeps will be heard and the hand held programmer will display the data currently programmed in "LOCATION 000".
2. Enter command 958 followed by the # button.
Two beeps will be heard and the number 4 will illuminate to indicate zones 1 - 4 are being displayed.

How To Disable Zone Status Mode

1. Enter command 958 followed by the # button.
Two beeps will be heard and you will return to the Installer's Programming Mode.

Example

A " - " in the display indicates the zone is unsealed.

A blank display indicates the zone is sealed.

α - 4 - - indicates that zone 1 is sealed and zones 2, 3 and 4 are unsealed.

- α 8 α - indicates that zones 5 and 8 are unsealed and zones 6 and 7 are sealed.

Command 959 - Test Programming Key

This command initiates a test to be carried out on the programming key. Only the Programming Key (CC891) may be used with the *Solution Ultima 844/862/880* control panel.

The programming key test is non-destructive and any data in the programming key will remain intact after the test has been completed. One long beep indicates that the programming key test has failed and two beeps indicates a successful test.

If the programming key has been removed before the test is complete or the programming key has failed, the data in the programming key has become corrupt. Remember not to remove the programming key while the activity LED is constantly illuminated or pulsing rapidly.

How To Test The Programming Key

1. Enter Installer's Programming Mode (i.e., **1234** followed by the **#** button). Two beeps will be heard and the STAY and AWAY indicators will begin to flash on the remote codepad to indicate that you have entered Installer's Programming Mode. You will also notice that the remote codepad will display the data currently programmed in "LOCATION 000".
2. Plug the programming key onto the pins marked PROGRAMMING KEY on the control panel found at the top of the PCB (printed circuit board) next to the Auxiliary Module socket.
3. Enter command **959** followed by the **#** button. Two beeps will be heard after the programming key has successfully been tested. If you heard a long beep after issuing this command, the programming key has become corrupt and will need to be erased to clear the corrupt data. Refer to Command 964 - Erase Programming Key on page 113 for more information.
4. Before removing the programming key from the control panel, enter command **960** followed by the **#** button to exit the Installer's Programming Mode. Two beeps will be heard. The STAY and AWAY indicators will now extinguish on the remote codepad and the system will return to the disarmed state.

Failing to exit Installer's Programming Mode before removing the programming key may result in corrupting the data in the programming key.

How To Test The Programming Key Using The Hand Held Programmer

1. Before connecting the hand held programmer onto the pins marked PROGRAMMING KEY, make sure that the switch on the hand held programmer is in the EXT position and that no external key has been plugged onto the hand held programmer.
2. Enter the Installer's Programming Mode (i.e.. 1 2 3 4 followed by the # button). Two beeps will be heard and the hand held programmer will display the data currently programmed in "LOCATION 000".
3. Plug the programming key onto the pins marked EXTERNAL KEY on the hand held programmer.
4. Enter command 959 followed by the # button.
Two beeps will be heard after the programming key has successfully been tested. If you heard a long beep after issuing this command, the programming key has become corrupt and will need to be erased to clear the corrupt data. Refer to Command 964 - Erase Programming Key on page 113 for more information.
5. Before removing the programming key from the hand held programmer, enter command 960 followed by the # button to exit the Installer's Programming Mode. Two beeps will be heard and the system will now return to the disarmed state.

Failing to exit Installer's Programming Mode before removing the programming key may result in corrupting the data in the programming key.

Command 960 - Exit Installer's Programming Mode

This command is used to exit the Installer's Programming Mode after you complete programming the control panel.

You may exit Installer's Programming Mode from any location by entering command 960 followed by the # button. Two beeps will be heard and the system will return to the disarmed state. When using the remote codepad to program the system, you will notice that the STAY and AWAY indicators will extinguish to indicate that you have terminated Installer's Programming Mode.

Command 961- Reset Control Panel Back To Factory Default Settings

This command will reset the control panel back to the factory default values. Refer to the default values shown throughout this manual or the programming sheets on pages 275 - 295 for more information.

You may reset the control panel back to the factory default settings from any location when in Installer's Programming Mode. This is achieved by entering command 961 followed by the # button. Two beeps will be heard and the system will default back to the factory default values.

Command 962 - Copy Control Panel Memory To Programming Key

This command is used to copy the control panel memory to the programming key. Only the Programming Key (CC891) may be used with the *Solution Ultima 844/862/880* control panel.

How To Copy The Control Panel Memory To The Programming Key

1. Enter Installer's Programming Mode (i.e., **1234** followed by the **#** button). Two beeps will be heard and the STAY and AWAY indicators will begin to flash on the remote codepad to indicate that you have entered Installer's Programming Mode. You will also notice that the remote codepad will display the data currently programmed in "LOCATION 000".
2. Plug the programming key onto the pins marked PROGRAMMING KEY on the control panel found at the top of the PCB (printed circuit board) next to the Auxiliary Module socket.
3. Enter command **962** followed by the **#** button. Two beeps will be heard after the control panel memory has successfully been copied into the programming key. If you heard a long beep after issuing this command, the programming key has become corrupt and will need to be erased to clear the corrupt data. Refer to Command 964 - Erase Programming Key on page 113 for more information.
4. Before removing the programming key from the control panel, enter command **960** followed by the **#** button to exit Installer's Programming Mode. The STAY and AWAY indicators will now extinguish on the remote codepad to indicate that the system has returned to the disarmed state.

Failing to exit Installer's Programming Mode before removing the programming key may result in corrupting the programming key.

How To Copy The Panel Memory To Programming Key Using The Hand Held Programmer

1. Before connecting the hand held programmer onto the pins marked PROGRAMMING KEY, make sure that the switch on the hand held programmer is in the EXT position and that no external key has been plugged onto the hand held programmer.
2. Enter Installer's Programming Mode (i.e., **1234** followed by the **#** button). Two beeps will be heard and the hand held programmer will display the data currently programmed in "LOCATION 000".
3. Plug the programming key onto the pins marked EXTERNAL KEY on the hand held programmer.
4. Enter command **962** followed by the **#** button. Two beeps will be heard after the control panel memory has successfully been copied into the programming key. If you heard a long beep after issuing this command, the programming key has become corrupt and will need to be erased to clear the corrupt data. Refer to Command 964 - Erase Programming Key on page 113 for more information.
5. Before removing the programming key from the hand held programmer, enter command **960** followed by the **#** button to exit Installer's Programming Mode. Two beeps will be heard and the system will now return to the disarmed state.

Failing to exit Installer's Programming Mode before removing the programming key may result in corrupting the programming key.

Command 963 - Copy From Programming Key To Control Panel

This command is used to copy data from the programming key to the control panel. Only the Programming Key (CC891) may be used with the *Solution Ultima 844/862/880* control panel.

How To Copy The Programming Key Memory To The Control Panel

1. Enter Installer's Programming Mode (i.e.. **1 2 3 4** followed by the **#** button). Two beeps will be heard and the STAY and AWAY indicators will begin to flash on the remote codepad to indicate that you have entered Installer's Programming Mode. You will also notice that the remote codepad will display the data currently programmed in "LOCATION 000".
2. Connect the programming key onto the pins marked PROGRAMMING KEY on the control panel found at the top of the PCB (printed circuit board) next to the Auxiliary Module socket.
3. Enter command **963** followed by the **#** button. Two beeps will be heard after the programming key's data has successfully been copied into to the control panel. If you heard a long beep after issuing this command, the programming key has become corrupt and will need to be erased to clear the corrupt data. Refer to Command 964 - Erase Programming Key on page 113 for more information.
4. Before removing the programming key from the control panel, enter command **960** followed by the **#** button to exit Installer's Programming Mode. The STAY and AWAY indicators will now extinguish on the remote codepad and the system will return to the disarmed state.

Failing to exit Installer's Programming Mode before removing the programming key may result in corrupting the programming key.

How To Copy Programming Key Memory To Control Panel Using Hand Held Programmer

1. Before connecting the hand held programmer onto the pins marked PROGRAMMING KEY, make sure that the switch on the hand held programmer is in the EXT position and that no external key has been plugged onto the hand held programmer.
2. Enter Installer's Programming Mode (i.e.. **1 2 3 4** followed by the **#** button). Two beeps will be heard and the hand held programmer will display the data currently programmed in "LOCATION 000".
3. Plug the programming key onto the pins marked EXTERNAL KEY on the hand held programmer.
4. Enter command **963** followed by the **#** button. Two beeps will be heard after the programming key's data has successfully been copied into to the control panel. If you heard a long beep after issuing this command, the programming key has become corrupt and will need to be erased to clear the corrupt data. Refer to Command 964 - Erase Programming Key on page 113 for more information.
5. Before removing the programming key from the hand held programmer, enter command **960** followed by the **#** button to exit Installer's Programming Mode. Two beeps will be heard and the system will now return to the disarmed state.

Failing to exit Installer's Programming Mode before removing the programming key may result in corrupting the programming key.

Command 964 - Erase Programming Key

This command erases all data from the programming key. Only the Programming Key (CC891) may be used with the *Solution Ultima 844/862/880* control panel.

How To Erase The Programming Key

1. Enter Installer's Programming Mode (i.e.. **1234** followed by the **#** button). Two beeps will be heard and the STAY and AWAY indicators will begin to flash on the remote codepad to indicate that you have entered Installer's Programming Mode. You will also notice that the remote codepad will display the data currently programmed in "LOCATION 000".
2. Connect the programming key onto the pins marked PROGRAMMING KEY on the control panel found at the top of the PCB (printed circuit board) next to the Auxiliary Module socket.
3. Enter command **964** followed by the **#** button. Two beeps will be heard after the programming keys data has been deleted.
4. Before removing the programming key from the control panel, enter command **960** followed by the **#** button to exit Installer's Programming Mode. The STAY and AWAY indicators will now extinguish on the remote codepad and the system will return to the disarmed state.

Failing to exit Installer's Programming Mode before removing the programming key may result in corrupting the programming key.

How To Erase The Programming Key Using The Hand Held Programmer

1. Before connecting the hand held programmer onto the pins marked PROGRAMMING KEY, make sure that the switch on the hand held programmer is in the EXT position and that no external key has been plugged onto the hand held programmer.
2. Enter Installer's Programming Mode (i.e.. **1234** followed by the **#** button). Two beeps will be heard and the hand held programmer will display the data currently programmed in "LOCATION 000".
3. Plug the programming key onto the pins marked EXTERNAL KEY on the hand held programmer.
4. Enter command **964** followed by the **#** button. Two beeps will be heard after the programming keys data has been deleted.
5. Before removing the programming key from the hand held programmer, enter command **960** followed by the **#** button to exit Installer's Programming Mode. Two beeps will be heard and the system will now return to the disarmed state.

Failing to exit Installer's Programming Mode before removing the programming key may result in corrupting the programming key.

Command 965 - Set Up Domestic Dialling Format

Command 965 has been included to allow the set up of the domestic dialling format a one step operation. Refer to page 126 for more information on Domestic Dialling Format.

After you enter Installer's Programming Mode, enter command **965** followed by the **#** button. The command will automatically set Receiver 1 to domestic reporting and set the following locations only for Receiver 2. No other locations will be changed when command 965 has been issued.

All domestic telephone numbers are stored in "LOCATION 478 – 525". For more information on programming domestic dialling, refer to Setting Up and Programming Domestic Reporting on page 127 for more information.

<i>Location</i>	<i>Description</i>	<i>Setting</i>	<i>Setting</i>
LOCATION 032	Handshake Tone For Receiver 1	1	(Handshake Tone)
LOCATION 033	Transmission Format	4	(Domestic)
LOCATION 034 – 039	Subscriber ID Number	0, 0, 0, 0, 0, 1	(1 Beep)
LOCATION 336	Zone Status Reporting Options	2	(Receiver 2 Only)
LOCATION 345 – 346	Open/Close Reports	11, 12	(Open/Close Reports)
LOCATION 347	Open/Close Reporting Options	2	(Receiver 2 Only)
LOCATION 368 - 370	System Status – Access Denied	6, 7, 12	(Access Denied)
LOCATION 371	System Status Reporting Options	2	(Receiver 2 Only)
LOCATION 372 - 378	Test Reporting Time	0, 0, 0, 0, 7, 1, 0	(Test Reports)
LOCATION 379	Test Reporting Dialler Options	1	(Receiver 1 Only)

Table 49: Command 965 Defaults

As you can see from the table above, the transmission format has automatically been set for domestic dialling and the Subscriber ID Number has been set for one identification beep. All reports except zone status reporting and system status reporting have been allocated to Receiver 1 for domestic dialling.

This means that the zone status reports including zone bypass, zone trouble, sensor watch and alarm restore codes as well as system status reports including fuse fail, AC fail, low battery and access denied reports have been allocated to Receiver 2 and will not report unless Receiver 2 has also been set up to report.

Command 966 - Enable/Disable Automatic Stepping Of Locations

This command allows automatic stepping of locations while programming via Installer's Programming Mode. When enabled via the hand held programmer, the decimal point of the left most display will reflect the mode of operation.

If the decimal point is illuminated on the hand held programmer, automatic stepping of locations is active. An automatic increment of the location being programmed will occur as soon as the * button is pressed positioning you at the next location ready for programming.

If the decimal point is not illuminated on the hand held programmer, the automatic stepping of locations is disabled and programming the next location will need to be manually selected by pressing the # button. As you can see from the examples below, auto step mode can be very useful when programming successive locations.

When programming via the remote codepad, there are no visual indications to display if automatic stepping of locations has been enabled.

How To Enable Automatic Stepping Of Locations

1. Enter Installer's Programming Mode (i.e.. 1 2 3 4 followed by the # button).
Two beeps will be heard.

If you are using the remote codepad, the STAY and AWAY indicators will begin to flash to indicate that you have entered Installer's Programming Mode. You will also notice that the remote codepad will display the data currently programmed in "LOCATION 000".

2. Enter command 966 followed by the # button.
Two beeps will be heard.

How To Disable Automatic Stepping Of Locations

1. Enter command 966 followed by the # button.
Two beeps will be heard.

Example

(Auto Step Enabled)

To enter the Primary Telephone Number "02 pause 9672 1055" with auto step enabled (i.e.. Decimal point illuminated when using the hand held programmer).

Press 0 followed by the # button.

(This will position you at "LOCATION 000" being the start of the Primary Telephone Number For Receiver 1).

10 + * + 2 + * + 13 + * + 9 + * + 6 + * + 7 + * +
 2 + * + 1 + * + 10 + * + 5 + * + 5 + * + 0 + *

*Example***(Auto Step Disabled)**

To enter the Primary Telephone Number "02 pause 9672 1055" with auto step disabled (i.e.. Decimal point extinguished when using the hand held programmer).

Press \bigcirc followed by the # button.

(This will position you at "LOCATION 000" being the start of the Primary Telephone Number For Receiver 1).

$\boxed{10} + * + \# + 2 + * + \# + \boxed{13} + * + \# + 9 + * + \# + 6$
 $+ * + \# + 7 + * + \# + 2 + * + \# + 1 + * + \# + \boxed{10} +$
 $* + \# + 5 + * + \# + 5 + * + \# + 0 + *$

Command 999 - Display Panel Type Or Software Version Number

When using this command via the remote codepad, the codepad will display the panel version of the control panel. As there are three different control panel's using the same PCB, it is difficult to know which control panel the PCB has been set up to be.

The codepad will display a 4, 6 or 8 depending on the software of the control panel. Refer to the "Table 50: Control Panel Type" below for more information.

<i>Indicator</i>	<i>Control Panel Type</i>
4	<i>Solution Ultima 844</i>
6	<i>Solution Ultima 862</i>
8	<i>Solution Ultima 880</i>

Table 50: Control Panel Type

When using this command via the hand held programmer, the hand held programmer will display the software version number of the control panel.

How To Display The Control Panel Type Or Software Version Number

1. Enter Installer's Programming Mode (i.e.. **1 2 3 4** followed by the **#** button).
Two beeps will be heard and the data currently programmed in "LOCATION 000" will be displayed via the hand held programmer or remote codepad.

If you are using the remote codepad, the STAY and AWAY indicators will begin to flash to indicate that you have entered Installer's Programming Mode.

2. Enter command **999** followed by the **#** button.
Two beeps will be heard.

If you are using the hand held programmer, the right display will indicate the software version number of the control panel.

If you are using the remote codepad, the codepad will display a zone indicator corresponding to the control panel type. Refer to "Table 50: Control Panel Type" above for more information.

3. Press the **#** button to exit this command and return to the Installer's Programming Mode.
4. Enter command **960** followed by the **#** button to exit Installer's Programming Mode.
Two beeps will be heard and the system will now return to the disarmed state.

If you are using the remote codepad, the STAY and AWAY indicators will extinguish to indicate that you have returned to the disarmed state.

LOCATION 900

This feature prevents the control panel from being manually defaulted via the default button or to prevent using a programming key to perform an automatic download to the control panel when the system is disarmed.

A zero programmed into this location will allow defaulting of the control panel. If 15 has been programmed into this location, defaulting of the control panel will not be permitted and the Installer Code MUST be used for further programming of the control panel.

If the Installer Code is not known, the control panel will need to be returned to Electronics Design and Manufacturing Pty Limited. A nominal fee applies for this service.



Electronics Design and Manufacturing Pty Limited does not recommend the use of this feature.

If the option is required to disable the option of being able to default the control panel, a special procedure has been implemented to eliminate the possibility of accidentally setting this option. The default button on the PCB must be held down while programming this location.

How To Prevent Manual Defaulting Of The Control Panel

1. Enter Installer's Programming Mode (i.e.. 1 2 3 4 followed by the # button).
Two beeps will be heard and the data currently programmed in "LOCATION 000" will be displayed via the hand held programmer or remote codepad.

If you are using a remote codepad, the STAY and AWAY indicators will begin to flash to indicate that Installer's Programming Mode has been accessed.
2. From the hand held programmer or remote codepad, go to "LOCATION 900".
(e.g.. 9 0 0 followed by the # button).
3. Hold down and continue to hold down the DEFAULT button.
The default button will be located at the top of the PCB next to the PROGRAMMING KEY connecting socket.
4. Program a 15 into "LOCATION 900".
(e.g.. 1 5 followed by the * button).
5. Release the default button.
6. Enter command 9 6 0 followed by the # button to exit Installer's Programming Mode.
Two beeps will be heard and the system will return to the disarmed state.

If you are using a remote codepad, the STAY and AWAY indicators will extinguish to indicate that the system has returned to the disarmed state.

Defaulting The Control Panel

If the *Solution Ultima 844/862/880* control panel does not have "LOCATION 900" programmed as 15, follow the procedure outlined below to successfully default the control panel back to the factory default settings.

How To Default The Control Panel Via Installer Code

1. Enter Installer Programming Mode.
(e.g., **1234** followed by the **#** button). Two beeps will be heard. The STAY and AWAY indicators will begin to flash to indicate that you have accessed programming mode.
2. Enter Installer's Programming Command **961** followed by the **#** button.
Two beeps will be heard after the control panel has successfully been defaulted.
3. Enter Installer's Programming Command **960** followed by the **#** button.
Two beeps will be heard. The STAY and AWAY indicators will cease to flash and the system will return to the disarmed state.

The control panel has now been successfully defaulted back to the factory default settings.

How To Default The Control Panel Via Default Button

1. Disconnect the AC mains supply and the backup battery from the control panel.
2. Hold down and continue to hold down the DEFAULT button.
The default button is located at the top of the PCB next to the PROGRAMMING KEY connecting socket.
3. Reconnect the AC mains supply to the control panel.
4. After reconnecting the AC mains supply, wait for 3-5 seconds before releasing the DEFAULT button.
5. Disarm the system using the default Master Code (e.g., Enter **2580** followed by the **#** button).

The control panel has now been successfully defaulted back to the factory default settings.



If you hear the dialler seize relay (RL2) click four times while attempting to default the control panel, this would indicate that the feature of defaulting the control panel has been disabled in "LOCATION 900" on page 118. The control panel will need to be returned to Electronics Design and Manufacturing Pty Limited for exchange where a service fee will be charged to unlock the control panel's memory if the Installer Code is not known.

Alarm Link Operations

This section includes the following:

- *Alarm Link Software*
- *Remote Connect*
- *Remote Connect With Customer Control*
- *Remote Connect Without Call Back Verification*
- *Remote Connect With Call Back Verification*
- *Direct Connect*
- *Alarm Link Options*

Alarm Link Software

The *Solution Ultima 844/862/880* control panel can be remotely programmed or controlled via an IBM or compatible personal computer via the Alarm Link Software (CC816). This facility will allow you to make alterations to your customers control panel without the need to leave your office, thus improving customer service and saving you time and money. For country locations where a control panel may be situated hundreds of kilometres from your office, the Upload/Download feature is invaluable.

When selecting the control panel type during the set up of a new customer database in the Alarm Link Software, refer to the table below to select the software version number that corresponds to the control panel type required.

<i>Control Panels Software Version</i>	<i>Select Panel Type</i>
Solution Ultima 844 - 1.00	S844_V10
Solution Ultima 862 - 1.00	S862_V10
Solution Ultima 880 - 1.00	S880_V10

Table 51: Alarm Link Panel Forms

After selecting the correct panel type when adding a new customer in the Alarm Link Software, the Subscriber ID Number and the Installer Code must match that of the control panel for synchronisation when making connection to the control panel. If these two locations do not match that of the control panel, the computer and the control panel will not synchronise.

Remote Connect

The remote connect feature allows you to establish a connection through the telephone network from your IBM or compatible computer to the *Solution Ultima 844/862/880* control panel anywhere in the country where a telephone line is present. The advantages of this are very obvious and having this facility will allow you to offer faster service to your clients.

Remote Connect With Customer Control

If you wish to configure the control panel so that a remote connection can only be established when the client initiates it through the remote codepad, you will need to program the following information.

"LOCATION 159 - 174" on page 147 will need to have the Call Back Telephone Number programmed and Option 1 in "LOCATION 180" on page 124/156 will need to be disabled. The control panel has now been set so that the client has control of when a remote connection can be established.

To activate the control panel to dial the remote computer to establish a link, hold the **6** button down until two beeps are heard on the remote codepad.

Remote Connect Without Call Back Verification

Remote connect without call back verification can be handy where you have a need to perform Upload/Download functions from multiple locations.

There are two methods that you may program so that the call back verification is disabled. It should be noted that by using this feature you are reducing the security of the control panel.

Method One

Method one allows you to call the control panel from any remote location without the need of having the control panel call back to the computer to establish a link. In using method one, the customer has no access to initiate a modem call by holding down the **6** button. The following locations need to be programmed for this method to operate.

"LOCATION 159 - 174" on page 147 should be programmed as zeros. Option 1 in "LOCATION 180" on page 124/156 will need to be enabled and Option 2 needs to be disabled. The control panel will now allow a connection of the first call without calling the remote computer back to make contact.

Method Two

Method two allows you to program a call back telephone number so that the customer can still initiate a modem call when required, but when calling the control panel via the computer from any remote location, the control panel does not call back the remote computer to establish a link.

"LOCATION 159 - 174" on page 147 should have the call back telephone number programmed if required. Option 1 in "LOCATION 180" on page 124/156 will need to be enabled and Option 2 needs to be disabled.

The control panel will now allow a connection of the first call without calling the remote computer back to make contact but still allow the customer to initiate a modem call by holding down the **6** button when required.

Remote Connect With Call Back Verification

Remote connect with call back verification offers the highest degree of data security by incorporating a two level security check.

The first is the Installer Code combined with the Subscriber ID Number needs to match that of the control panel. Secondly, the control panel will call back the programmed call back telephone number to establish the valid connection. The "Call Back Telephone Number" is the telephone line that the modem and computer has been connected to.

"LOCATION 159 - 174" on page 147 must be programmed with the Call Back Telephone Number and both Option 1 and Option 2 in "LOCATION 180" on page 124/156 will need to be enabled.

Direct Connect

The direct connect feature has been incorporated giving the installer a simple method for programming the *Solution Ultima 844/862/880* control panel at the office or on site visits using a portable computer. There is no need for telephone lines or modems, which makes programming of the control panel completed easily in minutes.

All that is required is the Direct Link Cable (CC808) connected to the correct serial port on your IBM or compatible computer and the other end to the auxiliary module socket on the control panel.

When using the direct connect method of connecting to the control panel, Option 1 in "LOCATION 180" on page 124/156 does not require to be enabled. The direct connect method of programming or operating the control panel will operate regardless of this option being set.

<i>Option</i>	<i>Description</i>
1	Enable Upload/Download Via Alarm Link
2	Enable Alarm Link Call Back
4	Terminate Alarm Link Connection On Alarm
8	Use External Modem Module (CC811) For Alarm Link Operations

Table 52: Alarm Link Options

Enable Upload/Download Via Alarm Link

- 1** This option will need to be selected if you require to use the Alarm Link Software (CC816) to remotely program the control panel. The control panel will not respond to the Alarm Link Software if this option is not selected. Refer to Alarm Link Software on page 122 for more information.

Enable Alarm Link Call Back

- 2** If this option has been selected and a call back telephone number has been programmed, the remote programming computer must be connected to the telephone line that has been programmed in the call back telephone number locations. Refer to “LOCATION 159 - 174” on page 147 for more information.

If this option is not selected, it will allow the installer to connect to their customers control panel from any remote location when attempting upload/download operations without the need to wait for the control panel to call back to the remote computer, but still allows the ability for the customer to initiate the modem call from the codepad when requested by holding down the **6** button. Refer to Alarm Link Software on page 122 for more information.

Terminate Alarm Link Connection On Alarm

- 4** If the control panel is communicating with a remote computer via Alarm Link Software (CC816) and an alarm has registered, the Alarm Link session will be terminated and the relevant alarm message will then be sent to the base station receiver.

If an alarm occurs that does not need to report to the base station receiver, the session will not be terminated. If this option has not been selected and an alarm has registered, the Alarm Link software will prompt the operator with a “Terminate” or “Continue” message.

Use External Modem Module (CC811) For Alarm Link Operations

- 8** If this option has been selected, the control panel will use the external plug-in Module (CC811) for remote programming operations via the Alarm Link Software (CC816). This option should only be enabled where the telephone line is susceptible to noise.

Domestic Dialling

This section includes the following:

- *Domestic Dialling Format*
- *Domestic Dialling Function*
- *Acknowledge Domestic Dialling*
- *Setting Up and Programming Domestic Reporting*
- *Disable Domestic Dialling*

Domestic Dialling Format

The locations of the primary telephone number and secondary telephone number for Receiver 1 or Receiver 2 are only used for base station reporting and pager reporting. When either Receiver 1 or Receiver 2 is set up for domestic reporting, both the primary telephone number and the secondary telephone number will be ignored.

The domestic dialling telephone numbers are located separately in "LOCATIONS 478 – 525" making provision to store up to 48 digits. The 48 locations are used to store any number of telephone numbers and subject to the length of each telephone number, it is possible to store 4 or more different telephone numbers for domestic dialling.

If both Receiver 1 and Receiver 2 have been set up for domestic reporting format, you would still have 48 data locations and both Receiver 1 and Receiver 2 would use the same domestic telephone numbers. The ability to program separate domestic telephone numbers for both Receiver 1 and Receiver 2 is not available.

Refer to Setting Up and Programming Domestic Reporting on page 127 for more information.

Domestic Dialling Function

When the control panel has activated into alarm condition, it will commence dialling the first telephone number programmed. If a busy or engaged tone has been detected, the control panel will hang up and commence dialling the second telephone number (if one is programmed). However, the first call will be counted as one unsuccessful dialling attempt. If the second telephone number is also busy or an engaged tone is detected, the control panel will hang up and commence dialling the third telephone number (if one is programmed) or return to the first telephone number.

If a busy tone is not detected, the control panel will assume that the telephone has been answered and will begin sending its transmission. The transmission sequence consists of an identification beep, followed by a siren tone and a long pause. The transmission sequence will repeat itself until the control panel receives an acknowledgment tone during the pause or the control panel automatically hangs up after a period of two minutes. The identification beep will allow the customer to verify which control panel made the call if more than one control panel is reporting to the same telephone number. The identification beep is programmed in "LOCATION 039" of the Subscriber ID Number For Receiver 1 or "LOCATION 079" of the Subscriber ID Number For Receiver 2.



A maximum of six calls per alarm event will be made when the control panel has been set up for "Domestic Dialling Format". This count includes any unsuccessful calls. The counter will be reset if the zone re-triggers and a further six attempts will be made. The control panel will stop dialling after six attempts or three successful calls. The control panel will also stop dialling if a valid user code has been entered at the remote keypad.

If both Receiver 1 and Receiver 2 have been programmed for domestic dialling, the maximum number of calls per alarm event is twelve.

Acknowledge Domestic Dialling

Once the call has been received, if it is not acknowledged during any of the transmission pauses by pressing the * button on a touch tone telephone or by using the Phone Controller (CC911), the control panel will continue to send its transmission for a period of 2 minutes. It will then hang up and commence dialling the next telephone number. If the call is successfully acknowledged, the control panel will hang up and no further calls will be made for that event.

Setting Up and Programming Domestic Reporting

Programming the control panel for domestic reporting has been made extremely simple by the use of the Installer's Programming Command 965. Refer to Command 965 - Set Up Domestic Dialling Format on page 114 for more information. However, if you wish to set up Receiver 2 for Domestic Dialling, you will need to manually program the reporting functions.

How To Set Up The Control Panel For Domestic Dialling

1. Enter Installer's Programming Mode (EG: 1234 followed by the **AWAY** button). Two beeps will be heard and the STAY and AWAY indicators will begin to flash.
2. Enter Command 965 followed by the **AWAY** button. Two beeps will be heard. The control panel has now been set up for Domestic Dialling Format. Refer to Command 965 - Set Up Domestic Dialling Format on page 114 for more information.
3. Exit Installer's Programming Mode by entering Command 960 followed by the **AWAY** button. Two beeps will be heard and the STAY and AWAY indicators will extinguish. The system will now return to the disarmed state.
4. Enter your **MASTER CODE** followed by 2 and the **AWAY** button. Three beeps will be heard and the STAY and AWAY indicators will begin to flash.

If there are telephone numbers programmed, they will be displayed one digit at a time via the codepad indicators.

If there are no telephone numbers programmed, a further two beeps will be heard after entering this mode. These two beeps are normally heard after the last digit of the last phone number has been displayed.

5. Enter all the digits for **PHONE No 1**, one digit at a time. You will notice as each digit is entered, the corresponding codepad indicators will illuminate.
6. If there is more than one telephone number, press the **STAY** button followed by the 4 button after the last digit of the telephone number. This will insert a break between the first telephone number and the second telephone number. If there is only one phone number, press the **AWAY** button to exit this mode.
7. Enter all the digits for **PHONE No. 2**, one digit at a time. You will notice as each digit is entered, the corresponding codepad indicators will illuminate.
8. After the last digit of the second telephone number, press the **AWAY** button to exit this mode unless a third telephone number is required. If there is a third telephone number to be programmed, press the **STAY** button followed by the 4 button to insert a break between the second telephone number and the third telephone.



MASTER CODE + 2 + **AWAY**
 + **PHONE No 1** + **STAY** + 4 + **PHONE No. 2** + **AWAY**

<i>Digit Required</i>	<i>Number To Program</i>	<i>Digit Required</i>	<i>Number To Program</i>
0	0	8	8
1	1	9	9
2	2		
3	3	*	<input type="button" value="STAY"/> Followed By 1
4	4	#	<input type="button" value="STAY"/> Followed By 2
5	5	Four Second Pause	<input type="button" value="STAY"/> Followed By 3
6	6	Break	<input type="button" value="STAY"/> Followed By 4
7	7	15	<input type="button" value="STAY"/> Followed By 5

Table 53: Domestic Dialling Digits

Example

If you wish to program two separate telephone numbers (9672 1777 and 9672 1233), follow the sequence below and replace the telephone numbers mentioned in the manual with the telephone numbers that you wish to program.



2580 + 2 +
 + 96721777 + + 4
 + 96721233 +

Disable Domestic Dialling

If at any time you wish to cancel domestic dialling for any reason (e.g.. You are moving house and do not wish the system to continue calling your work place or mobile phone etc), you may enter the following sequence.



+ 2 + + + 4 +

Dialler Reporting Formats

This section includes the following:

- *Transmission Formats*
- *Contact ID Format*
- *Point ID Codes*
- *4+2 Reporting Format*
- *Basic Pager Reporting Format*
- *Basic Pager Display Information*

Transmission Formats

When making use of the control panel's dialling and communication features, there are a number of transmission formats available. Refer to "LOCATION 033" on page 141 to set the required transmission format for Receiver 1 and "LOCATION 073" on page 144 to set the required transmission formation for Receiver 2. The *Solution Ultima 844/862/880* control panel comes factory default to report in the Contact ID Format.

Contact ID Format

This format can identify hundreds of protection zones by their unique code and provides a single digit event qualifier and a three-digit event code that quickly identifies the condition being reported.

<i>Subscriber ID Number</i>	<i>Qualifier</i>	<i>Event Code</i>	<i>Group Number</i>	<i>Point ID Number</i>
SSSS	Q	XYZ	GG	CCC
Four Digit Subscriber ID Number	Event Qualifier, Which Gives Specific Event Information. 1 = New Event Or Opening 3 = New Restore Or Closing	Event Code (Made Up Of 3 Hex Digits)	Group Number (Made Up Of 2 Hex Digits)	Point ID Number (Made Up Of 3 Hex Digits)

Table 54: Contact ID Format Breakdown

In general, Contact ID reporting format is very simple as most of the Event Codes and Point ID Codes have been predefined. The base station software usually only has the ability to identify a zone going into alarm by its Point ID Code and usually pays little attention to the Event Code.

Refer to "Table 55: Point ID Codes" on page 132 for further information on the *Solution Ultima 844/862/880* Point ID Codes.

Point ID Codes

The table below shows the different Point ID Codes and Event Codes that are sent to the base station receiver when using Contact ID Reporting Format. All event codes are fixed and will always send the same code as there are no programming locations made available to alter these.

<i>Event Code</i>	<i>Event Description</i>	<i>Point ID Number</i>	<i>Explanation</i>	<i>Page</i>
130	Burglary Zone	Zone Specific 1 - 8	Burglary	Page 171
100	Medical Zone		24 Hour Medical	Page 171
120	Panic Zone		24 Hour Panic	Page 171
122	Hold-Up Zone		24 Hour Hold-Up	Page 171
137	Tamper Zone		24 Hour Tamper	Page 171
133	Burglary Zone		24 Hour Burglary	Page 171
110	Fire		24 Hour Fire	Page 171
401	Open/Close Report	User Specific 1 - 16	Opening – User # Closing – User #	Page 189
402	Open/Close Report Partitioned	User Specific 1 - 16	Opening – User # Closing – User #	Page 189
456	Partial Close Report	User Specific 1 - 16	Closing – User #	Page 154
301	AC Mains Fail	030	AC Power	Page 193
309	Low Battery	031	Battery Test Failure	Page 194
121	Codepad Duress	User Specific 1 - 16	Duress Alarm	Page 190
120	Codepad Panic	041	Panic Alarm	Page 190
110	Codepad Fire	046	Fire Alarm	Page 191
100	Codepad Medical	045	Medical Alarm	Page 191
421	Code Retry Limit Exceeded	042	Access Denied	Page 195
602	Test Report - Automatic	044	Test Report	Page 197
602	Test Report After Siren Reset	047	Test Report	Page 231
307	Sensor Self Test Failure	Zone Specific 1 - 8	Sensor Watch	Page 186
		Zone Specific 1 - 8	RF Device Supervision	Page 187
380	Trouble	Zone Specific 1 - 8	Sensor Trouble	Page 185
300	Fuse Fail	00	System Trouble	Page 192

<i>Event Code</i>	<i>Event Description</i>	<i>Point ID Number</i>	<i>Explanation</i>	<i>Page</i>
607	Walk Test	User Specific	Walk Test Mode	Page 184
144	Tamper	Zone Specific 1 - 8	Zone Tamper	Page 184
384	RF Low Battery	Zone Specific 1 - 8	RF Low Battery	Page 187
355	RF Receiver Fail	001	RF Receiver Jamming	Page 188
		002	RF Receiver Tamper Switch	Page 188
		003	RF Receiver Failure	Page 188
573	Bypass	Zone Specific 1 - 8	Zone Bypass	Page 185
572	Bypass	Zone Specific 1 - 8	24-Hour Zone Bypass	Page 185
571	Bypass	Zone Specific 1 - 8	24-Hour Fire Zone Bypass	Page 185

Table 55: Point ID Codes

4 + 2 Reporting Format

The 4+2 Express Format will report a Subscriber ID Number followed by an expansion code and the reporting channel number is sent directly after the expansion code.

<i>Subscriber ID Number</i>	<i>Expansion Code</i>	<i>Channel Number</i>
SSSS	A	C _H

Table 56: Example Reporting In 4+2 Format

<i>New Event</i>	<i>4 + 2 Report</i>	<i>Event</i>	<i>4 + 2 Report</i>
Alarm	SSSS AC _H	Alarm Restore	SSSS R C _H
Trouble	SSSS TC _H	Trouble Restore	SSSS TR C _H
Bypass	SSSS BC _H	Bypass Restore	SSSS B _R C _H
AC Fail	SSSS EAC	AC Fail Restore	SSSS E _R AC _R
Low Battery	SSSS LL _B	Low Battery	SSSS L L _B
Opening Report	SSSS OU	Low Battery Restore	SSSS L _R L _{BR}
Closing Report	SSSS CU	Panic	SSSS P P _{CH}
Test Report	SSSS T _E		
Program Altered	SSSS P0		
Duress	SSSS DD ₀		

Table 57: 4 + 2 Reporting Format

<i>Code</i>	<i>Description</i>	<i>Code</i>	<i>Description</i>
SSSS	Subscriber ID Number	R	Alarm Restore Code
A	Alarm	TR	Trouble Restore Code
C_H	Channel Number	B_R	Bypass Restore Code
0	Zero	E_R	AC Fail Restore Code 1 st Digit
T	Trouble	AC_R	AC Fail Restore Code 2 nd Digit
B	Bypass	L_R	Low Battery Restore Code 1 st Digit
E	AC Fail Code 1 st Digit	L_{BR}	Low Battery Restore Code 2 nd Digit
AC	AC Fail Code 2 nd Digit	D	Duress Code 1 st Digit
L	Low Battery Code 1 st Digit	D₀	Duress Code 2 nd Digit
L_B	Low Battery Code 2 nd Digit	P	Panic Code 1 st Digit
O	Open	P_{CH}	Panic Code 2 nd Digit
C	Close	T_E	Test Code
U	User Number		

Table 58: 4 + 2 Transmission Code Descriptions

Basic Pager Reporting Format

Basic Pager Format requires some interpretation of the numbers that appear on the display; however, it is possible to differentiate between 1000 different control panels when a number of control panels are reporting to the one pager.

How To Set up Receiver 1 For Basic Pager Reporting

1. "LOCATION 000 - 015" on page 139 requires the Basic Pager's access telephone number programmed.
2. "LOCATION 034 - 039" on page 141 requires a Subscriber ID Number programmed.
3. "LOCATION 032" on page 140 requires "Option 5 - Pager Handshake" to be selected.
4. "LOCATION 033" on page 141 requires "Option 5 - Basic Pager Format" to be selected.

How To Set up Receiver 2 For Basic Pager Reporting

1. "LOCATION 040 - 055" on page 142 requires the Basic Pager's access telephone number programmed.
2. "LOCATION 074 - 079" on page 144 requires a Subscriber ID Number programmed.
3. "LOCATION 072" on page 143 requires "Option 5 - Pager Handshake" to be selected.
4. "LOCATION 073" on page 144 requires "Option 5 - Basic Pager Format" to be selected.

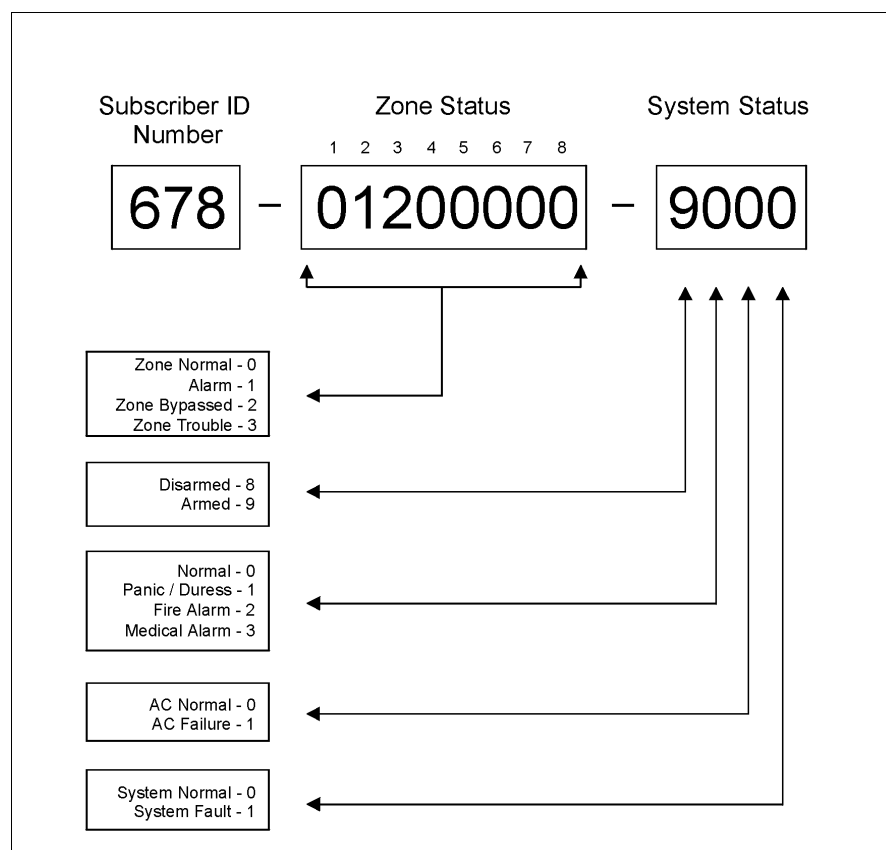

Figure 5: Basic Pager Display

The example in "Figure 5: Basic Pager Display" shows that the transmission has come from Subscriber ID Number 678 and that Zone 2 is in alarm, Zone 3 has been manually isolated, the system is armed, the panic zone is normal, the AC is connected and there is no fault condition.

Basic Pager Display Information

Subscriber ID Number

This is the identification number of the control panel and is programmed in “LOCATION 034 – 039” on page 141 for Receiver 1 and “LOCATION 074 – 079” on page 144 for Receiver 2. The pocket pager will only display the last three digits of the Subscriber ID Number.

Zone Status

The zone status display shows you the status of each zone (1 - 8) of the control panel. The following table below describes what each number means when displayed on the zone status display of the pocket pager.

<i>Number Displayed</i>	<i>Zone Description</i>
0	Zone Normal This indicates that the corresponding zone is in the sealed state.
1	Alarm This indicates that the corresponding zone is unsealed and in alarm condition.
2	Zone Bypassed This indicates that a system operator has manually isolated the corresponding zone. Refer to Isolating Zones on page 48 for information on how to manually isolate a zone(s) prior to arming the system. Refer to Zone Status – Bypass Reports on page 185 for more information.
3	Zone Trouble (Software Version 1.02) This indicates that a zone was left unsealed after the end of exit time. Refer to Zone Status – Trouble Reports on page 185 for more information.

Table 59: Zone Status Display Descriptions

System Status

The system status information is divided up into 4 digits. The first digit of the system status display indicates whether the system is armed or disarmed (8 = Disarmed / 9 = Armed).

The second digit on the system status display indicates which codepad alarm was triggered by the operator (0 = No Codepad Alarm / 1 = Codepad Panic or Duress / 2 = Codepad Fire Alarm / 3 = Codepad Medical Alarm). Refer to Figure 4: CP5 LED Codepad Showing Audible Alarm Buttons on page 47 for more information.

The third digit on the system status display indicates when the AC mains supply has failed (0 = AC mains supply is normal / 1 = AC mains supply has failed or disconnected).

The fourth digit on the system status display indicates when a system fault has occurred at the control panel (0 = System Normal – There is no faults / 1 = System Fault – There is a fault registered by the control panel). Refer to Fault Analysis Mode on page 51 for more information on the types of system faults that may occur.

Dialler Information

This section includes the following:

- *Dialler Information*
- *Primary Telephone Number For Receiver 1*
- *Secondary Telephone Number For Receiver 1*
- *Handshake Tone For Receiver 1*
- *Transmission Format For Receiver 1*
- *Subscriber ID Number For Receiver 1*
- *Primary Telephone Number For Receiver 2*
- *Secondary Telephone Number For Receiver 2*
- *Handshake Tone For Receiver 2*
- *Transmission Format For Receiver 2*
- *Subscriber ID Number For Receiver 2*
- *Dialling Format*
- *Telco Arming Sequence*
- *Telco Disarming Sequence*
- *Call Back Telephone Number*
- *Ring Count*
- *Telephone Line Fault Options*

Dialler Information

This section outlines the programming information required for the *Solution Ultima 844/862/880* control panel when communicating with base station receivers. Typically these parameters specify the telephone numbers to call, the transmission formats, handshake tones and transmission speeds.

The *Solution Ultima 844/862/880* has the ability to report event information from two on-board diallers. The first dialler reports to Receiver 1 and the second dialler reports to Receiver 2. Each dialler has the ability to be programmed with two separate telephone numbers, handshake tone, reporting format type and Subscriber ID Number.

Example

Dialler 1 could be set up to report in Domestic Dialling Format and reports to Receiver 1. Dialler 2 could be set up to report to a base station receiver in Contact ID Format only when Dialler 1 was unsuccessful.

How To Program A Telephone Number

When programming the telephone number, if a '0' is required, it must be programmed as a '10'. Each location in the primary, secondary and call back telephone numbers hold one digit of the telephone number.

To tell the dialler when the end of the telephone number has been reached, a '0' must be inserted at the end of the telephone number. Therefore the dialling sequence will be terminated when a zero appears.

Example

To program the telephone number 9672 1055 as the Primary Telephone Number for Receiver 1, you would program the following:

LOCATION 000 - 015

96721 105500000000.

Programming A Four Second Pause In The Telephone Number

To enter a four-second pause in the dialling sequence, you would need to program the value '13'. This may be necessary when the dialler is communicating through an old (slower) telephone exchange or where a PABX system is in place.

Example

To program the telephone number 02 pause 9672 1055 as the Primary Telephone Number for Receiver 2, you would program the following:

LOCATION 040 - 055

10213967211055000000.

<i>Digit Required</i>	<i>Number To Program</i>	<i>Digit Required</i>	<i>Number To Program</i>
Terminator	0	8	8
1	1	9	9
2	2	0	10
3	3	*	11
4	4	#	12
5	5	Four Second Pause	13
6	6	Break	14
7	7	15	15

Table 60: Dialling Digits

LOCATION 032**1**

This location sets the type of handshake tone required for Receiver 1 before data transmissions to the monitoring station will begin.

1. HI LO Handshake Tone is required when the control panel requires to communicate in Contact ID Format or High Speed DTMF.
2. 1400 Hz Handshake Tone is required when the control panel requires to communicate in Ademco Lo Speed Format or Domestic Dialling Format.
3. Reserved.
4. No Handshake Tone is not recommended.
5. Pager Handshake Tone is required when the control panel needs to communicate in Basic Pager Format.

<i>Option</i>	<i>Handshake Tone</i>	<i>Option</i>	<i>Handshake Tone</i>
1	HI LO Handshake (Contact ID Format)	4	No Handshake
2	1400 Hz Lo Speed (Ademco Tx At 1900Hz)	5	Pager Handshake
3	2300 Hz (Low Speed Sescoa)		

Table 61: Handshake Tones For Receiver 1

Transmission Format For Receiver 1**LOCATION 033****1**

Enter the desired transmission format here. This location selects the data format that will be sent to the base station receiver. This location also allows you to configure the control panel for domestic or basic pager formats.

<i>Option</i>	<i>Transmission Format</i>	<i>Option</i>	<i>Transmission Format</i>
1	Contact ID	4	Domestic
2	4 + 2 Express	5	Basic Pager
3	FSK (300 Baud) BELL		

Table 62: Transmission Formats For Receiver 1

Subscriber ID Number For Receiver 1**LOCATION 034 – 039**

○○○○○○

This number is sent to identify the calling control panel. Enter the desired Subscriber ID Number in the six locations provided.

For Basic Pager Format, “LOCATION 034 – 036” will be ignored and the first digit of the Subscriber ID Number required must start in “LOCATION 037”.

When using Domestic Dialling Format, the number of identification beeps will be the number that is programmed in “LOCATION 039”. This gives the ability to identify between 15 different control panels calling the same telephone number.

Example

If you wish to program the Subscriber ID Number as 4729, you would program the six locations as follows:

004729

Primary Telephone Number For Receiver 2

LOCATION 040 - 055

○○○○○○○○○○○○○○○○○○○○

When the control panel requires to send a report, the control panel will dial this number in an attempt to contact the monitoring station or pager etc. If the call is successful, the relevant information will be sent and the dialler will return back to the stand-by mode.

If unsuccessful, the dialler will attempt two more times using the primary telephone number for Receiver 1, after which the secondary telephone number for Receiver 1 will be called three times. If the dialling sequence is still unsuccessful, the control panel will then attempt to repeat this procedure dialling the primary telephone number and the secondary telephone number for Receiver 2 if programmed.

This procedure will be repeated only once again (i.e.. Maximum of 12 call attempts per alarm) after ten minutes if none of the first 6 attempts were successful if only the primary telephone number and secondary telephone number for Receiver 1 has been programmed.

If the primary telephone number and secondary telephone numbers for both Receiver 1 and Receiver 2 have been programmed, a maximum of 24 call attempts per alarm will be made.

Contact your monitoring station or pager company for the relevant telephone numbers before programming these locations.



When Receiver 2 has been set up for domestic reporting, telephone numbers programmed into these locations will be ignored. Refer to Changing Domestic Phone Numbers on page 66 when using the Installer Code function and Changing Domestic Phone Numbers on page 81 when using the Master Code function.

Secondary Telephone Number For Receiver 2

LOCATION 056 - 071

○○○○○○○○○○○○○○○○○○○○

Refer to the Primary Telephone Number For Receiver 2 on page 142 for more information.



When Receiver 2 has been set up for domestic reporting, telephone numbers programmed into these locations will be ignored. Refer to Changing Domestic Phone Numbers on page 66 when using the Installer Code function and Changing Domestic Phone Numbers on page 81 when using the Master Code function.

LOCATION 072**1**

This location programs the type of handshake tone required for Receiver 2 before data transmissions to the monitoring station will begin.

1. HI LO Handshake Tone is required when the control panel requires to communicate in Contact ID Format or High Speed DTMF.
2. 1400 Hz Handshake Tone is required when the control panel requires to communicate in Ademco Lo Speed Format or Domestic Dialling Format.
3. Reserved.
4. No Handshake Tone is not recommended.
5. Pager Handshake Tone is required when the control panel needs to communicate in Basic Pager Format.

<i>Option</i>	<i>Handshake Tone</i>	<i>Option</i>	<i>Handshake Tone</i>
1	HI LO Handshake (Contact ID Format)	4	No Handshake
2	1400 Hz Lo Speed (Ademco Tx At 1900Hz)	5	Pager Handshake
3	2300 Hz (Low Speed SESCOA)		

Table 63: Handshake Tones For Receiver 2

Transmission Format For Receiver 2**LOCATION 073****1**

Enter the desired transmission format here. This location selects the data format that will be sent to the base station receiver. This location also allows you to configure the control panel for domestic or basic pager formats.

<i>Option</i>	<i>Transmission Format</i>	<i>Option</i>	<i>Transmission Format</i>
1	Contact ID	4	Domestic
2	4 + 2 Express	5	Basic Pager
3	FSK (300 Baud) BELL		

Table 64: Transmission Formats For Receiver 2

Subscriber ID Number For Receiver 2**LOCATION 074 – 079**

○○○○○○

This number is sent to identify the calling control panel. Enter the desired Subscriber ID Number in the six locations provided.

For Basic Pager Format, “LOCATION 074 – 076” will be ignored and the first digit of the Subscriber ID Number required must start in “LOCATION 077”.

When using Domestic Dialling Format, the number of identification beeps will be the number that is programmed in “LOCATION 079”. This gives the ability to identify between 15 different control panels calling the same telephone number.

Example

If you wish to program the Subscriber ID Number as 4729, you would program the six locations as follows:

○○4729

Telco Disarming Sequence

LOCATION 143 – 158



These locations allow you to automatically deactivate call diversion on your telephone when you disarm the system from AWAY Mode.

<i>Digit Required</i>	<i>Number To Program</i>	<i>Digit Required</i>	<i>Number To Program</i>
Terminator	0	8	8
1	1	9	9
2	2	0	10
3	3	*	11
4	4	#	12
5	5	Four Second Pause	13
6	6	Break	14
7	7	15	15

Table 67: Telco Arm/Disarm Dialling Digits

Telco Arming – Call Forward Immediate Off

To turn Call Forward Immediate Off:

2 1

Example

If you wish to disable the Telco Arming – Call Forward Immediate upon disarming the system from AWAY Mode, you would program the following:

12 2 1 **12** ○○○○○○○○○○○○○○○○○

Telco Arming – Call Forward No Answer Off

To turn Call Forward No Answer Off:

6 1

Example

If you wish to disable the Telco Arming – Call Forward No Answer upon disarming the system from AWAY Mode, you would program the following:

12 6 1 **12** ○○○○○○○○○○○○○○○○○

Call Back Telephone Number

LOCATION 159 - 174



This location contains the telephone number that the control panel will dial when Upload/Download is requested or the number 6 button is held down to initiate a modem call from the control panel to establish a communications link with the remote computer. The computer must be running the Alarm Link Software (CC816) and will need to be set to "Waiting For An Incoming Call". The Call Back Telephone Number is also required to be programmed if Remote Connect With Call Back Verification on page 123 is required.

Refer to the section - Alarm Link Operations beginning on page 121 for more information.

LOCATION 175

8

This location sets the number of rings before the control panel will answer an incoming call. This should be set at an acceptable level bearing in mind that one ring = "Ring, Ring - Ring, Ring" and that a ring count of 10 represents approximately 60 seconds. This location only has an effect if remote arming and/or remote Upload/Download via Alarm Link Software has been enabled. If this location is programmed as 'zero', then the answering of incoming calls will be totally disabled irrespective of any programmed options.

Answering Machine Bypass

Answering machine bypass has been incorporated so that it is possible to make a connection with the control panel for remote arming or Upload/Download when there is an answering machine or facsimile machine on the same telephone line. There are two different methods of using answering machine bypass as explained below. The secondary method should only be used when there is a large amount of traffic on the line (e.g.. A home office). It will reduce the chance of the control panel incorrectly answering incoming calls.

1. Programming the ring count as 15 will enable "Answering Machine Bypass" in the primary mode. When calling the control panel, let the phone ring for no more than 4 rings and then hang up. If you call again within 45 seconds, the control panel will answer the call on the first ring and the connection will be established. This will prevent the answering machine or facsimile from answering the call. Refer to Option 4 in "LOCATION 177" on page 153 if you wish to enable Answering Machine Bypass Only When System Is Armed.
2. Programming a 14 as the ring count will enable "Answering Machine Bypass" in the secondary mode. In this mode, when calling the control panel, allow the phone to ring for no more than 2 rings and then hang up. Wait a minimum of 8 seconds before calling the control panel again. The control panel will now answer on the first ring. If you do not wait the 8 seconds, the control panel will not answer the call. Refer to Option 4 in "LOCATION 177" on page 153 if you wish to enable Answering Machine Bypass Only When System Is Armed.



You should set the ring count on the answering machine or facsimile machine to be higher than two rings. Four or six rings would be preferred.

Programming a zero into this location will disable the control panel from answering an incoming call.

LOCATION 176



When programming this location, you will notice that there are four options per location. If you require options 1, 2, 4 or all of these options, only one number needs to be programmed. This number is calculated by adding the option bit numbers together. Program a 7 if you require options 1, 2 and 4 simultaneously (i.e.. $1 + 2 + 4 = 7$).

<i>Option</i>	<i>Description</i>
1	Display FAULT Indicator When Telephone Line Fails
2	Sound Alarm When System Is Armed
4	Sound Alarm When System Is Disarmed
8	Reserved

Table 68: Telephone Line Fault Options

The *Solution Ultima 844/862/880* has the ability to monitor the telephone line. If the telephone line has been cut or disconnected for more than forty seconds, the control panel will recognise this and the FAULT indicator will illuminate on the codepad. The FAULT indicator will extinguish once the telephone line has been restored for more than forty seconds.



Option 2 and 4 will not operate unless option 1 has been enabled.

Operate The FAULT Indicator When Telephone Line Fails

- 1** The FAULT indicator will flash and the codepad buzzer will beep once every minute if the control panel detects that the telephone line has been disconnected. Refer to Fault Descriptions on page 53 for more information.

Sound Speaker, Bell and Strobe When The System Is Armed

- 2** Option 1 in this location will also need to be selected for this option to operate. If the control panel detects that the telephone line has been disconnected when the system is armed in AWAY Mode, STAY Mode 1 or STAY Mode 2, the horn speaker, bell and strobe outputs will operate. Refer to Option 2 in LOCATION 179 on page 155 to program Lockout Telephone Line Fail Alarm when only one audible alarm per arming cycle is required.

Sound Speaker, Bell and Strobe When The System Is Disarmed

- 4** Option 1 in this location will also need to be selected for this option to operate. If the control panel detects that the telephone line has been disconnected when the system is disarmed, the horn speaker, bell and strobe outputs will operate. Refer to Option 2 in LOCATION 179 on page 155 to program Lockout Telephone Line Fail Alarm when only one audible alarm per arming cycle is required.

- 8** *Reserved*



If Options 1, 2 and 4 have been added together, the horn speaker, bell, strobe and EDMSAT outputs will operate when the system is armed or disarmed.

LOCATION 748 - 749

46

<i>Location</i>	<i>Description</i>
748	Increments Of 5 ms
749	Increments Of 80 ms

Table 69: Ring Burst Time Locations

(V1.07+) These locations program the ring burst time (Default = 500 ms). If the duration of the telephone ring tone is 1.5 seconds, programming the ring burst time more than the telephone ring duration (1.5 seconds); the control panel will not detect an incoming call. Always program the ring burst time less than the duration of the ring tone.



These locations are factory set and should not be changed unless required.

Dialler Options

This section includes the following:

- *Dialler Options 1*
- *Dialler Options 2*
- *Dialler Options 3*
- *Alarm Link Options*

Programming Option Bits

When programming these locations, you will notice that there are four options per location. You may select one, two, three or all four of these options, however, only one number needs to be programmed. This number is calculated by adding the option bit numbers together.

Example

If at "LOCATION 177" you want options 1, 2 and 4, add the numbers together and the total is the number to be programmed. In this example, the number to be programmed is 7 (i.e.. $1 + 2 + 4 = 7$).

<i>Option</i>	<i>Description</i>
1	Dialler Reporting Functions Allowed
2	Remote Arming Via The Telephone Allowed
4	Answering Machine Bypass Only When Armed
8	Use Bell 103 For FSK Format (Disabled = CCITT V21)

Table 70: Example - Programming Option Bits

<i>Option</i>	<i>Description</i>
1	Dialler Reporting Functions Allowed
2	Remote Arming Via The Telephone Allowed
4	Answering Machine Bypass Only When Armed
8	Use Bell 103 For FSK Format (Disabled = CCITT V21)

Table 71: Dialler Options 1

Dialler Reporting Functions Allowed

- 1 If this option has been selected, the dialler will function for all operations. Upload/Download via Alarm Link Software (CC816) and telephone remote arming will remain operational regardless of this setting.

Disabled = Disable All Dialler Reporting Functions

If this option is not selected, the communication dialler will not operate. Upload/Download via Alarm Link Software (CC816) and telephone remote arming will remain operational regardless of this setting.

Remote Arming Via The Telephone Allowed

- 2 If this option has been selected, you can remotely arm the system via a standard telephone using the Phone Controller (CC911) or by pressing the * button on your touch-tone telephone. Refer to Remote Arming Via The Telephone on page 100 for more information. Forced arming is automatically assumed when this feature is being used. Refer to Zone Options 2 on page 179 for more information on forced arming.

If the dialler has been disabled, it will have no effect on remote arming via the telephone. Refer to Ring Count on page 148 for programming the number of rings before the control panel will answer an incoming call.

Answering Machine Bypass Only When Armed

- 4 This option needs to be selected if the answering machine bypass feature is required to operate only when the system has been armed in AWAY Mode, STAY Mode 1 or STAY Mode 2. When the system is disarmed, the control panel will not answer any incoming calls. This option is beneficial in high telephone traffic installations where the control panel could answer an incoming call. Refer to Ring Count on page 148 to program answering machine bypass.

Use Bell 103 For FSK Format (Disabled = CCITT V21 Format)

- 8 If this option is enabled, the control panel will use the transmission frequency BELL 103 at 300 baud. If this option is disabled, the control panel will use the transmission frequency CCITT V21 at 300 baud.

LOCATION 178



<i>Option</i>	<i>Description</i>
1	Open/Close Reports Only If Previous Alarm
2	Open/Close Reports For STAY Mode 1 and STAY Mode 2
4	Delay Siren Until Transmission Complete
8	Extend Time To Wait For Handshake From 30 To 55 Seconds

Table 72: Dialler Options 2

Open/Close Reports Only If Previous Alarm

1 This option requires Open/Close reports in “LOCATION 345 - 346” to be enabled on page 189 for it to be effective.

An opening report will be sent to the base station receiver when the system has been disarmed after an alarm has occurred. When the system has been armed, a closing report will be sent. An opening or closing report will not report again until the system has registered another alarm condition.

If using a *Solution Ultima 880* control panel that has been partitioned, an Open/Close report will only be sent on the area that the alarm had occurred.



If the system is disarmed when an alarm occurs, only a closing report will be sent when the system is next armed.

User codes that have their priority set to “Always Send Open/Close” reports will override this feature, which means that they will always send open/close reports.

Open/Close Reports For STAY Mode 1 and STAY Mode 2

2 If open and close reports are required when the system is armed in STAY Mode 1 or STAY Mode 2, this option will need to be selected.

This option requires Open/Close reports in “LOCATION 345 - 346” to be enabled on page 189 for it to be effective. When arming in STAY Mode 1 or STAY Mode 2, a “Partial Close” report (Contact ID Event Code 456) will be sent.

Delay Siren Until Transmission Complete

4 If this option has been selected, the EDMSAT, horn speaker, bell and strobe outputs will not activate until the base station receiver has sent a kiss-off back to the control panel after the message has been sent. If multiple messages are sent, the sirens will activate after the last kiss-off has been sent.

However, the EDMSAT, horn speaker, bell and strobe outputs will activate as soon as a codepad panic, fire and medical alarms have been activated.

Extend Time To Wait For Handshake From 30 - 55 Seconds

8 The control panel after dialling the monitoring station will wait approximately 30 seconds for receipt of a valid handshake tone. The handshake tone indicates to the control panel that it has reached the monitoring station and can now send its messages. Enabling this option will extend the wait time from 30 seconds to 55 seconds.

LOCATION 179

(Default For Software Version 1.00 - 1.03 = 0)

2

<i>Option</i>	<i>Description</i>
1	Set DTMF Dialling Pulses To 1 Digit/Second
2	Lockout Telephone Line Fail Alarm (New - Software Version 1.03)
4	Change Decadic Dialling To 60/40
8	Reserved

Table 73: Dialler Options 3

Set DTMF Dialling Pulses To 1 Digit/Second

1 If this option is not selected, the dialling format – Australian DTMF dials at the rate of 5 digits per second (i.e.. 100 ms tone, 100 ms pause, 100 ms tone, 100 ms pause).

If this option has been selected, the dialling format – Australian DTMF dials at the rate of 1 digit per second (i.e.. 500 ms tone, 500 ms pause).

Lockout Telephone Line Fail Alarm

2 (New - Software Version 1.03) This option if programmed will only allow an audible alarm once per arming cycle when the control panel detects that the telephone line has been cut or disconnected. This option bit does not follow the swinger shutdown count for siren where you can program how many times a zone may sound an alarm during the arming cycle. Refer to LOCATION 176 on page 149 to program the telephone line fault options.

Change Decadic Dialling To 60/40

4 Some countries have different requirements for decadic dialling. Setting this option will change the dialling characteristics from 65/35 (Australian Standard) to 60/40. This option should only be set when the control panel is used in a country that requires decadic dialling as 60/40. This option has no effect when using DTMF tone dialling.

External Modem Module (CC811) Required For FSK

8 If this option is enabled, the control panel will use the FSK transmission frequency BELL 103 at 300 baud via the optional external Modem Module (CC811). Use the CC811 modem module for CCITT V21 and use the CC811B modem module for Bell 103.

<i>Option</i>	<i>Description</i>
1	Upload/Download Allowed
2	Call Back Phone Number Required For Upload/Download
4	Exit Upload/Download Connection On Alarm
8	External Modem Module (CC811) Required For Upload/Download

Table 74: Alarm Link Options

Upload/Download Allowed

- 1** This option will need to be selected if you require to use the Alarm Link Software (CC816) to remotely program the control panel. The control panel will not respond to the Alarm Link Software if this option is not selected. Refer to Alarm Link Software on page 122 for more information. The direct connect method will always operate irrespective of this option being set.

Call Back Phone Number Required For Upload/Download

- 2** If this option has been selected and a call back telephone number has been programmed, the remote programming computer must be connected to the telephone line that has been programmed in the call back telephone number locations. Refer to “LOCATION 159 - 174” on page 147 to program the call back telephone number.

If this option is not selected, it will allow the installer to connect to their customers control panel from any remote location when attempting upload/download operations without the need to wait for the control panel to call back to the remote computer, but still allows the ability for the customer to initiate the modem call from the codepad when requested by holding down the **6** button. Refer to Alarm Link Software on page 122 for more information.

Exit Upload/Download Connection On Alarm

- 4** If the control panel is communicating with a remote computer via Alarm Link Software (CC816) and an alarm has registered, the “Alarm Link” session will be terminated and the relevant alarm message will then be sent to the base station receiver.

If an alarm occurs that does not need to report to the base station receiver, the session will not be terminated. If this option has not been selected and an alarm has registered, the Alarm Link software will prompt the operator with a “Terminate” or “Continue” message.

External Modem Module (CC811) Required For Upload/Download

- 8** If this option has been selected, the control panel will use the external plug-in Modem Module (CC811) for remote programming operations via the Alarm Link Software (CC816). This option should only be enabled where the telephone line is susceptible to noise.

User Codes

This section includes the following:

- *Installer Code*
- *User Codes*
- *User Code Priority*

Access Codes

This section describes the access codes that are used to assign privileges and access functions for user code holders of the system. Two types of user codes exist within the system, the Installer Code and User Codes. Each of these codes allow specific access and operation of the varied functions of the control panel.

Installer Code

LOCATION 181 - 184

1 2 3 4

This code is used to access the Installer's Programming Mode and can be between one to four digits long. However, after the control panel has been powered up, the Installer Code can disarm the system if it is the first code used. The next time the Installer Code is used, access into Installer's Programming Mode will be made.

Installer Code functions are available to allow the installer to carry out various functions during the disarmed state without the need to remember the customers Master Code. Refer to Installer Code Functions on page 62 for more information.

Refer to Programming With The Remote Codepad on page 103 for more information on programming the system once Installer's Programming Mode has been accessed.

LOCATION 185 - 264

The purpose of user codes is to arm and disarm the system as well as perform other specific functions as described in Master Code Functions on page 76.

User codes (1–8) can be any length between one to four digits long. Each user code may have a different priority level or multiple user codes may have the same priority level. The priority level controls the behaviour of the code, allowing it to arm only, arm and disarm or be a Master Code holder etc. The priority level of each user code is programmed in the last location of each user code and can only be programmed by the installer. The Master Code holder does not have any ability to change the priority level of any user code.

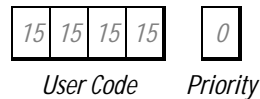

There are a total of 16 user codes available that can be changed or deleted at any time by a Master Code holder, however, user codes 9 – 16 can only be remote radio user codes. Refer to Remote Radio Transmitter Operations on page 56 for more information. Multiple Master Codes can be programmed. Refer to Master Code Functions on page 76 for more information on adding, deleting or changing user codes.



The priority level for each user code can only be programmed or changed by the installer.

User Code 16 will report when any of the following methods for arming and disarming are used.

1. Arm and disarm via remote radio control equipment connected to the optional Radio Key/Keyswitch Interface (CC813) or the 2 Channel Radio Interface (RE005).
2. Arm and disarm the system via Alarm Link Software (CC816).
3. Arm the system remotely over the telephone.
4. Single button arming in AWAY Mode, STAY Mode 1 or STAY Mode 2.
5. Single button disarming from STAY Mode 1 or STAY Mode 2.
6. Automatic arming in AWAY Mode or STAY Mode 1.
7. Automatic disarming from AWAY Mode or STAY Mode 1 or STAY Mode 2.

Solution Ultima 844/862 User Codes

The *Solution Ultima 844/862* has the ability to have up to eight programmable user codes (User Codes 1 – 8) to operate the system. Refer to System Operations on page 40 for information on the different methods of arming and disarming the system.

User codes 9 – 16 have been included to allow those systems that require radio remote control via hand held remote Transmitters. Refer to Remote Radio Transmitter Operations on page 56 for information on remote operations and adding and deleting remote radio user codes.

		Location 185 - 189		Location 190 - 194													
	<i>User Code 1</i>	2	5	8	0	10	<i>User Code 2</i>	15	15	15	15	2					
		Location 195 - 199		Location 200 - 204		Location 205 - 209		Location 210 - 214		Location 215 - 219		Location 220 - 224					
<i>User Code 3</i>	15	15	15	15	2	<i>User Code 4</i>	15	15	15	15	2	<i>User Code 5</i>	15	15	15	15	2
<i>User Code 6</i>	15	15	15	15	2	<i>User Code 7</i>	15	15	15	15	2	<i>User Code 8</i>	0	15	15	15	3
		Location 225 - 229		Location 230 - 234		Location 235 - 239		Location 240 - 244		Location 245 - 249		Location 250 - 254					
<i>Radio Code 9</i>	15	15	15	15	2	<i>Radio Code 10</i>	15	15	15	15	2	<i>Radio Code 11</i>	15	15	15	15	2
<i>Radio Code 12</i>	15	15	15	15	2	<i>Radio Code 13</i>	15	15	15	15	2	<i>Radio Code 14</i>	15	15	15	15	2
<i>Radio Code 15</i>	15	15	15	15	2	<i>Radio Code 16</i>	15	15	15	15	2						

Solution Ultima 880 User Codes

The *Solution Ultima 880* has the ability to have up to sixteen programmable user codes (User Codes 1 – 16). Refer to System Operations on page 40 for information on the different methods of arming and disarming the system.

However, if you wish to remotely operate the system via hand held remote Transmitters, user codes 9 – 16 may be programmed as remote user codes. Refer to Remote Radio Transmitter Operations on page 56 for information on remote operations and adding and deleting remote radio user codes.

		Location 185 - 189		Location 190 - 194													
	<i>User Code 1</i>	2	5	8	0	10	<i>User Code 2</i>	15	15	15	15	2					
		Location 195 - 199		Location 200 - 204		Location 205 - 209		Location 210 - 214		Location 215 - 219		Location 220 - 224					
<i>User Code 3</i>	15	15	15	15	2	<i>User Code 4</i>	15	15	15	15	2	<i>User Code 5</i>	15	15	15	15	2
<i>User Code 6</i>	15	15	15	15	2	<i>User Code 7</i>	15	15	15	15	2	<i>User Code 8</i>	0	15	15	15	3
		Location 225 - 229		Location 230 - 234		Location 235 - 239		Location 240 - 244		Location 245 - 249		Location 250 - 254					
<i>User Code 9</i>	15	15	15	15	2	<i>User Code 10</i>	15	15	15	15	2	<i>User Code 11</i>	15	15	15	15	2
<i>User Code 12</i>	15	15	15	15	2	<i>User Code 13</i>	15	15	15	15	2	<i>User Code 14</i>	15	15	15	15	2
<i>User Code 15</i>	15	15	15	15	2	<i>User Code 16</i>	15	15	15	15	2						

User Code Priority

There are ten different priority levels that can be allocated to the user code. Each priority level allows or restricts the functions that different user code holders may perform and can only be changed by the installer.



Once user code priority levels 4, 6, 12 or 14 have been programmed to any of the available user codes, the method of standard isolating will no longer operate. Only those user codes with the priority level of 4, 6, 12 or 14 will be able to isolate zones using the method code to isolate.

Priority	Description	Priority	Description
0	Arm/Disarm	6	Arm/Disarm + Code To Isolate + Open/Close Report
1	Arm Only	8	Arm/Disarm + Master Code Functions
2	Arm/Disarm + Open/Close Report	10	Arm/Disarm + Master Code Functions + Open/Close Report
3	Arm Only + Close Report	12	Arm/Disarm + Master Code Functions + Code To Isolate
4	Arm/Disarm + Code To Isolate	14	Arm/Disarm + Master Code Functions + Code To Isolate + Open/Close Report

Table 75: User Code Priority Levels

Arm and Disarm

- 0 This priority level allows the user code holder to arm and disarm the system. No opening or closing reports will be sent when this user code has been used to arm or disarm the system. However, a user code with this priority level will only send a closing report only after a previous code that has the ability to send an opening report has disarmed the system.

Arm Only

- 1 This priority level allows the user code holder to arm the system but not disarm it. No closing reports will be sent when this user code has been used to arm the system. However, a user code with this priority level will only send a closing report only after a previous code that has the ability to send an opening report has disarmed the system.

Arm and Disarm + Open/Close Reports

- 2 This priority level allows the user code holder to arm and disarm the system. When this user code has been used, an opening or closing report will always be sent along with the user number that armed or disarmed the system.

This option requires Open/Close reports in "LOCATION 345 - 346" to be enabled on page 189 for it to be effective.

Arm Only + Closing Reports

- 3 This priority level allows the user code holder to arm the system but not disarm it. When this user code has been used, a closing report will always be sent along with the user number that armed the system.

This option requires Open/Close reports in "LOCATION 345 - 346" to be enabled on page 189 for it to be effective.

Arm and Disarm + Code To Isolate

- 4 This priority level allows the user code holder to arm and disarm the system. No opening or closing reports will be sent when this user code has been used to arm or disarm the system. However, a user code with this priority level will only send a closing report after a previous code that has the ability to send an opening report has disarmed the system.

Isolating zones will only be allowed by using the method “Code To Isolate” once this priority level has been set. Refer to Isolating Zones on page 48 for further information.

Arm and Disarm + Code To Isolate + Open/Close Reports

- 6 This priority level allows the user code holder to arm and disarm the system. Opening and closing reports will always be sent when this user code has been used to arm or disarm the system. Isolating of zones will only be allowed by using the method “Code To Isolate” once this priority level has been set.

This option requires Open/Close reports in “LOCATION 345 - 346” to be enabled on page 189 for it to be effective. Refer to Isolating Zones on page 48 for more information.

Arm and Disarm + Master Code Functions

- 8 This priority level allows arming and disarming of the system and the ability to carry out any of the Master Code Functions described on page 76. No opening or closing reports will be sent when this user code has been used to arm or disarm the system. However, a user code with this priority level will only send a closing report after a previous code that has the ability to send an opening report has disarmed the system.

Arm and Disarm + Master Code Functions + Open/Close Reports

- 10 This priority level allows arming and disarming of the system and the ability to carry out any of the Master Code Functions described on page 76. Opening and closing reports will always be sent when this user code has been used to arm or disarm the system.

This option requires Open/Close reports in “LOCATION 345 - 346” to be enabled on page 189 for it to be effective.

Arm and Disarm + Master Code Functions + Code To Isolate

- 12 This priority level allows arming and disarming of the system and the ability to carry out any of the Master Code Functions described on page 76. No opening and closing reports will be sent when this user code has been used to arm or disarm the system. However, a user code with this priority level will only send a closing report after a previous code that has the ability to send an opening report has disarmed the system.

Isolating zones will only be allowed by using the method “Code To Isolate” once this priority level has been set. Refer to Isolating Zones on page 48 for more information.

Arm and Disarm + Master Code Functions + Code To Isolate + Open/Close Reports

- 14 This priority level allows arming and disarming of the system and the ability to carry out any of the Master Code Functions described on page 76. Opening and closing reports will always be sent when this user code has been used to arm or disarm the system. This option requires Open/Close reports in “LOCATION 345 - 346” to be enabled on page 189 for it to be effective. Refer to Isolating Zones on page 48 for more information.

Isolating zones will only be allowed by using the method Code To Isolate once this priority level has been set.

Zone Information

This section includes the following:

- *Day Alarm Zones*
- *Day Alarm Operation*
- *EOL Resistor Value*
- *Connections Of Split EOL Resistors Using N/C Contacts*
- *Connections Of Split EOL Resistors Using N/O Contacts*
- *Zone Programming*
- *Solution Ultima 844 Zones Defaults*
- *Solution Ultima 862 Zones Defaults*
- *Solution Ultima 880 Zones Defaults*
- *Zone Types*
- *Zone Pulse Count*
- *Zone Pulse Count Handover*
- *Zone Pulse Count Time*
- *Zone Options 1*
- *Keyswitch Zone Options*
- *Zone Options 2*
- *Zone Reporting Information*
- *Swinger Shutdown Count For Siren*
- *Swinger Shutdown Count For Dialler*

LOCATION 265



When programming this location, you will notice that there are four options per location. You may select one, two, three or all four of these options, however, only one number needs to be programmed. This number is calculated by adding the option bit numbers together. Program a seven (7) if you require options 1, 2 and 4 simultaneously (i.e.. $1 + 2 + 4 = 7$).

<i>Option</i>	<i>Day Alarm Zone</i>
1	Zone 1
2	Zone 2
4	Zone 3
8	Zone 4

Table 76: Day Alarm Zones 1 - 4

Day alarm allows a combination of zones to be monitored while the system is in the disarmed state. Indications are available via any of the programmable outputs including the codepad buzzer. This function has been expanded to accommodate latching and non-latching day alarm output event types.

When the system has been armed in AWAY Mode, STAY Mode 1 or STAY Mode 2, zones that have been programmed as day alarm zones will activate the sirens and dialler just as non day alarm zones do. When day alarm has been turned on, it will ignore any zone pulse count settings that have been programmed for that zone (i.e.. Zone pulse count is only relevant when the system has been armed).

Example

An example of a day alarm set up could be the front door of a shop that has a pressure mat or electronic beam that customers activate as they enter to and from the shop. As the customers walk on the pressure mat or break the electronic beam, the codepad buzzer will beep.

Day Alarm Resetting

An output that has been programmed for day alarm resetting will operate when a zone programmed for day alarm has been triggered. The output will reset once the zone has resealed. This will only occur when the system is disarmed. Refer to Output Event Type - Day Alarm Resetting on page 204 for more information.

Day Alarm Latching

An output that has been programmed for day alarm latching will operate when a zone programmed for day alarm has been triggered. The ZONE indicator and the latching output will reset when the button has been pressed. This will only occur when the system is disarmed. Refer to Output Event Type - Day Alarm Latching on page 204 for more information.

Day Alarm Operation

If a zone has been programmed for day alarm, the zone can be isolated in the normal way so that it does not register as a day alarm zone during the disarmed state. Only zones 1 – 4 can be used as day alarm zones.

The STAY indicator can be programmed to indicate whether day alarm has been turned on or off. When day alarm has been turned on, the STAY indicator will flash once every three seconds. Refer to Option 8 in “LOCATION 440” on page 231 for more information.

Monitoring of zones 5 – 8 can be achieved by programming an output to mimic a zone. Refer to Output Event Types on page 202 for more information on all available output types that can be programmed.

How To Turn Day Alarm On

1. Hold down the 4 button until three beeps are heard.

How To Turn Day Alarm Off

1. Hold Down the 4 button until two beeps are heard.

LOCATION 266

15

Option	Resistor Value	Option	Resistor Value
0	No EOL Resistor	8	6K8 (Blue, Grey, Black, Brown) 1%
1	1K (Brown, Black, Red)	9	10K (Brown, Black, Orange)
2	1K5 (Brown, Green, Red)	10	12K (Brown, Red, Orange)
3	2K2 (Red, Red, Red)	11	22K (Red, Red, Orange)
4	3K3 (Orange, Orange, Black, Brown) 1%	12	Reserved
5	3K9 (Orange, White, Red)	13	Reserved
6	4K7 (Yellow, Violet, Red)	14	Split EOL (3K3/6K8) With Tamper (1K)
7	5K6 (Green, Blue, Red)	15	Split EOL (3K3/6K8) 1% Resistors Required Four Burglary Zones & Four 24 Hour Zones.

Table 77: EOL Resistor Value

The control panel has the ability to be programmed for different values of EOL (End Of Line) resistors. This is a global parameter and will effect all four zones simultaneously. It gives the ability to fit the *Solution Ultima 844/862/880* control panel into an existing installation without having to change the EOL resistors. This feature also increases the security of the system as there are eleven possible EOL resistor values that can be used. This makes it extremely difficult for anyone to tamper with the system.

If split EOL resistors have been selected, the control panel will look for four burglary zones (1-4) consisting of 3K3 EOL resistors and four 24 hour zones (5-8) consisting of 6K8 resistors connected in parallel. The zone 1 terminal on the PCB becomes the terminal for zones 1 and 5.



Caution should be exercised when using split EOL resistors to create eight burglary zones and four 24-hour zones. This configuration is normally only suitable for N/C contacts. If N/O contacts are used, as is the case with most types of smoke detectors, a short circuit on one zone will trigger both zones connected in parallel.

If you require N/O contacts when using split EOL resistors, refer to Connections Of Split EOL Resistors Using N/O Contacts on page 168 for more information.

Connections Of Split EOL Resistors Using N/C Contacts

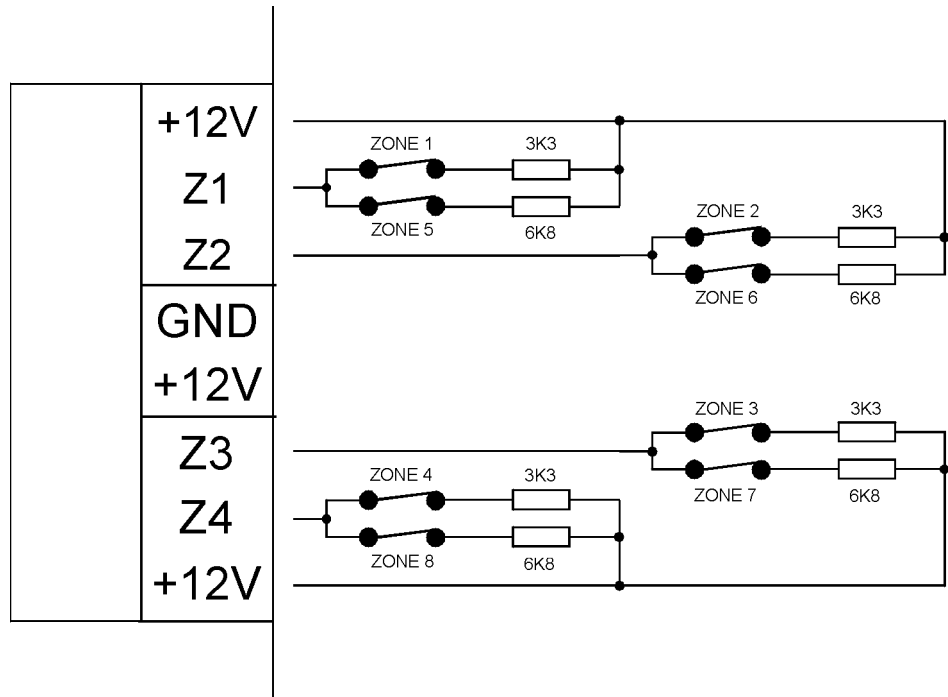

Figure 6: Connections Of Split EOL Resistors For 8 Zones

Connections Of Split EOL Resistors With Tamper Circuit

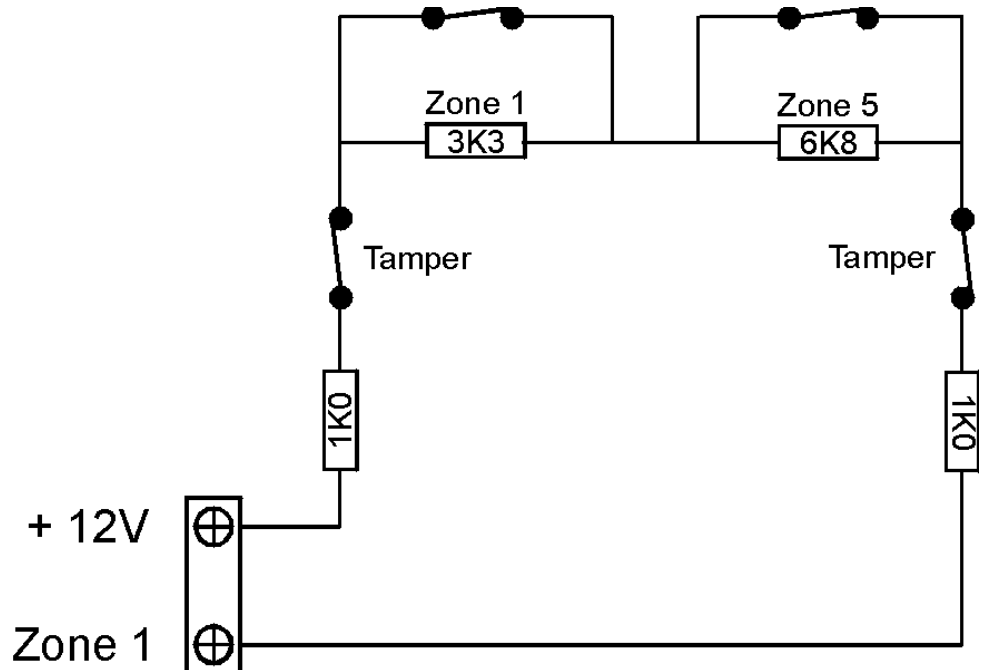

Figure 7: Connections Of Split EOL With Tamper Circuit

Connections Of Split EOL Resistors Using N/O Contacts

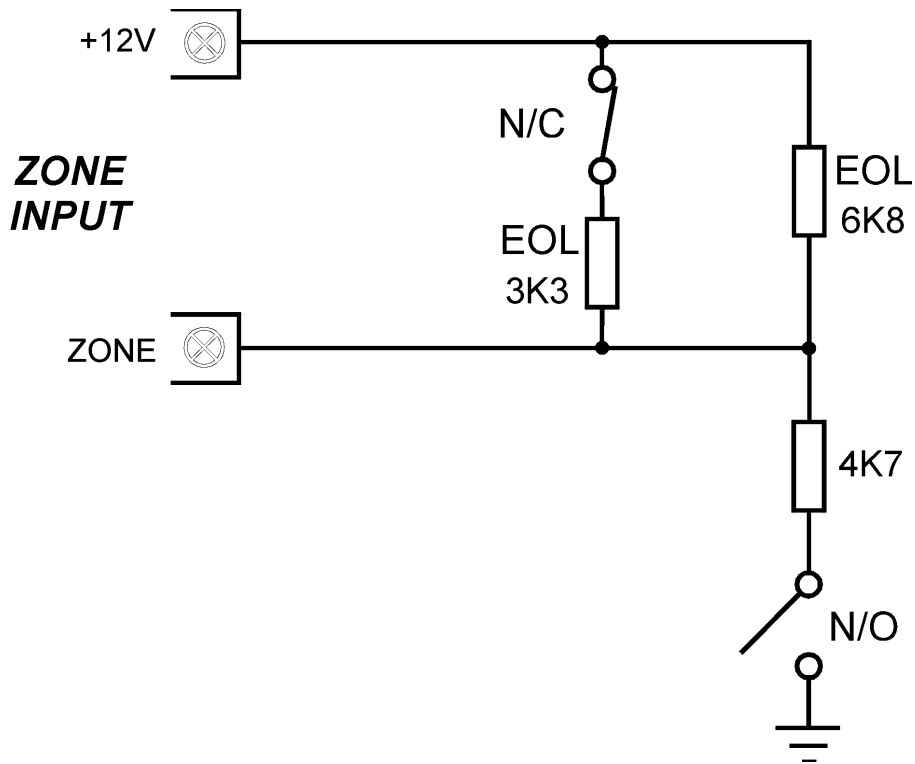

Figure 8: Connections Of Split EOL Resistors Using One N/O Contact

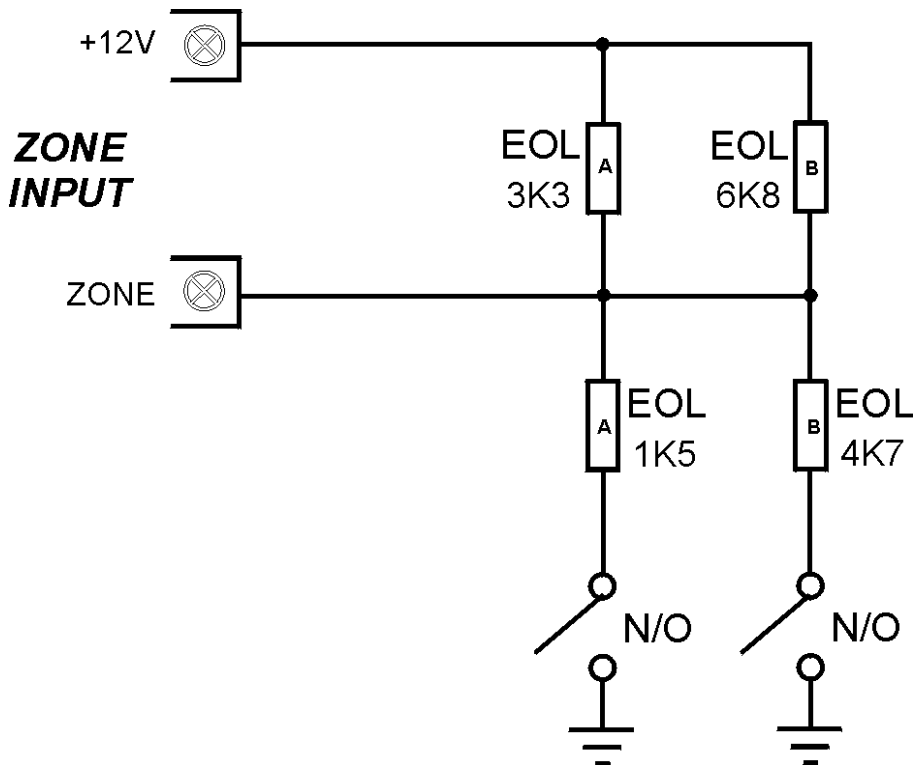

Figure 9: Connections Of Split EOL Using Two N/O Contacts

Zone Programming

Each zone contains seven locations that are divided into three groups. The first 3 locations determine how the zone will operate, the next two locations allow various options for each zone and the last two locations contain the dialler reporting information of each zone.

Zone Operating Information

Zone Type

This location programs the "Zone Type" required (e.g.. Delay-1, Instant, 24 Hour etc).

Zone Pulse Count

This location sets how many times the zone must trigger within the time specified in the "Zone Pulse Count Time".

Zone Pulse Count Time

This parameter sets the time period for the number of times the zone must trigger before activating an alarm.

Zone Options

Zone Options 1

This location controls the zone (e.g.. Lockout Siren, Silent etc).

Zone Options 2

This location controls the zone (e.g.. Isolate In STAY Mode 1, Forced Arming Allowed etc).

Zone Reporting Information

Zone Report Code

If you wish the control panel to send zone alarm reports, this location should be programmed as 1. If you do not wish to send zone alarm reports, this location should be programmed as a 0.

Zone Dialler Options

This location is factory default to report only to Receiver 1. You can select each zone to report on Receiver 1, Receiver 2, both Receiver 1 and Receiver 2, Receiver 2 only when Receiver 1 fails or no reporting at all. Select the required dialler option from the table below.

<i>Option</i>	<i>Description</i>
0	No Report Required
1	Receiver 1
2	Receiver 2
4	Receiver 1 and Receiver 2
8	Receiver 2 Only When Receiver 1 Fails

Table 78: Zone Dialler Options

Solution Ultima 844 Zones Defaults

LOCATION 267 - 322

		Zone 1 Location 267 - 273	Zone 2 Location 274 - 280																					
		<table border="1"><tr><td>2</td><td>0</td><td>0</td><td>1</td><td>14</td><td>1</td><td>1</td></tr></table>	2	0	0	1	14	1	1	<table border="1"><tr><td>1</td><td>0</td><td>0</td><td>1</td><td>14</td><td>1</td><td>1</td></tr></table>	1	0	0	1	14	1	1							
2	0	0	1	14	1	1																		
1	0	0	1	14	1	1																		
Zone 3 Location 281 - 287	Zone 4 Location 288 - 294	Zone 5 Location 295 - 301																						
<table border="1"><tr><td>1</td><td>0</td><td>0</td><td>1</td><td>14</td><td>1</td><td>1</td></tr></table>	1	0	0	1	14	1	1	<table border="1"><tr><td>0</td><td>0</td><td>0</td><td>1</td><td>14</td><td>1</td><td>1</td></tr></table>	0	0	0	1	14	1	1	<table border="1"><tr><td>12</td><td>0</td><td>0</td><td>1</td><td>12</td><td>1</td><td>1</td></tr></table>	12	0	0	1	12	1	1	
1	0	0	1	14	1	1																		
0	0	0	1	14	1	1																		
12	0	0	1	12	1	1																		
Zone 6 Location 302 - 308	Zone 7 Location 309 - 315	Zone 8 Location 316 - 322																						
<table border="1"><tr><td>12</td><td>0</td><td>0</td><td>1</td><td>12</td><td>1</td><td>1</td></tr></table>	12	0	0	1	12	1	1	<table border="1"><tr><td>13</td><td>0</td><td>0</td><td>1</td><td>12</td><td>1</td><td>1</td></tr></table>	13	0	0	1	12	1	1	<table border="1"><tr><td>9</td><td>0</td><td>0</td><td>1</td><td>12</td><td>1</td><td>1</td></tr></table>	9	0	0	1	12	1	1	
12	0	0	1	12	1	1																		
13	0	0	1	12	1	1																		
9	0	0	1	12	1	1																		
<table border="1"><tr><td> </td></tr></table>		<table border="1"><tr><td> </td></tr></table>		<table border="1"><tr><td> </td></tr></table>		<table border="1"><tr><td> </td></tr></table>																		
Zone Type	Zone Pulse Count	Zone Pulse Count Time	Zone Option 1																					
			Zone Option 2																					
			Report Code																					
			Dialler Options																					

Zones 1 – 4 may be programmed as any zone type, whereas zones 5 – 8 may only be programmed to any 24-hour zone type.

Solution Ultima 862 Zones Defaults

LOCATION 267 - 322

		Zone 1 Location 267 - 273	Zone 2 Location 274 - 280																					
		<table border="1"><tr><td>2</td><td>0</td><td>0</td><td>1</td><td>14</td><td>1</td><td>1</td></tr></table>	2	0	0	1	14	1	1	<table border="1"><tr><td>1</td><td>0</td><td>0</td><td>1</td><td>14</td><td>1</td><td>1</td></tr></table>	1	0	0	1	14	1	1							
2	0	0	1	14	1	1																		
1	0	0	1	14	1	1																		
Zone 3 Location 281 - 287	Zone 4 Location 288 - 294	Zone 5 Location 295 - 301																						
<table border="1"><tr><td>1</td><td>0</td><td>0</td><td>1</td><td>14</td><td>1</td><td>1</td></tr></table>	1	0	0	1	14	1	1	<table border="1"><tr><td>1</td><td>0</td><td>0</td><td>1</td><td>14</td><td>1</td><td>1</td></tr></table>	1	0	0	1	14	1	1	<table border="1"><tr><td>0</td><td>0</td><td>0</td><td>1</td><td>14</td><td>1</td><td>1</td></tr></table>	0	0	0	1	14	1	1	
1	0	0	1	14	1	1																		
1	0	0	1	14	1	1																		
0	0	0	1	14	1	1																		
Zone 6 Location 302 - 308	Zone 7 Location 309 - 315	Zone 8 Location 316 - 322																						
<table border="1"><tr><td>0</td><td>0</td><td>0</td><td>1</td><td>14</td><td>1</td><td>1</td></tr></table>	0	0	0	1	14	1	1	<table border="1"><tr><td>13</td><td>0</td><td>0</td><td>1</td><td>12</td><td>1</td><td>1</td></tr></table>	13	0	0	1	12	1	1	<table border="1"><tr><td>9</td><td>0</td><td>0</td><td>1</td><td>12</td><td>1</td><td>1</td></tr></table>	9	0	0	1	12	1	1	
0	0	0	1	14	1	1																		
13	0	0	1	12	1	1																		
9	0	0	1	12	1	1																		
<table border="1"><tr><td> </td></tr></table>		<table border="1"><tr><td> </td></tr></table>		<table border="1"><tr><td> </td></tr></table>		<table border="1"><tr><td> </td></tr></table>																		
Zone Type	Zone Pulse Count	Zone Pulse Count Time	Zone Option 1																					
			Zone Option 2																					
			Report Code																					
			Dialler Options																					

Zones 1 – 6 may be programmed as any zone type, whereas zones 7 and 8 may only be programmed to any 24-hour zone type.

Solution Ultima 880 Zones Defaults

LOCATION 267 - 322

		Zone 1 Location 267 - 273	Zone 2 Location 274 - 280																					
		<table border="1"><tr><td>2</td><td>0</td><td>0</td><td>1</td><td>14</td><td>1</td><td>1</td></tr></table>	2	0	0	1	14	1	1	<table border="1"><tr><td>1</td><td>0</td><td>0</td><td>1</td><td>14</td><td>1</td><td>1</td></tr></table>	1	0	0	1	14	1	1							
2	0	0	1	14	1	1																		
1	0	0	1	14	1	1																		
Zone 3 Location 281 - 287	Zone 4 Location 288 - 294	Zone 5 Location 295 - 301																						
<table border="1"><tr><td>1</td><td>0</td><td>0</td><td>1</td><td>14</td><td>1</td><td>1</td></tr></table>	1	0	0	1	14	1	1	<table border="1"><tr><td>1</td><td>0</td><td>0</td><td>1</td><td>14</td><td>1</td><td>1</td></tr></table>	1	0	0	1	14	1	1	<table border="1"><tr><td>0</td><td>0</td><td>0</td><td>1</td><td>14</td><td>1</td><td>1</td></tr></table>	0	0	0	1	14	1	1	
1	0	0	1	14	1	1																		
1	0	0	1	14	1	1																		
0	0	0	1	14	1	1																		
Zone 6 Location 302 - 308	Zone 7 Location 309 - 315	Zone 8 Location 316 - 322																						
<table border="1"><tr><td>0</td><td>0</td><td>0</td><td>1</td><td>14</td><td>1</td><td>1</td></tr></table>	0	0	0	1	14	1	1	<table border="1"><tr><td>0</td><td>0</td><td>0</td><td>1</td><td>14</td><td>1</td><td>1</td></tr></table>	0	0	0	1	14	1	1	<table border="1"><tr><td>9</td><td>0</td><td>0</td><td>1</td><td>12</td><td>1</td><td>1</td></tr></table>	9	0	0	1	12	1	1	
0	0	0	1	14	1	1																		
0	0	0	1	14	1	1																		
9	0	0	1	12	1	1																		
<table border="1"><tr><td> </td></tr></table>		<table border="1"><tr><td> </td></tr></table>		<table border="1"><tr><td> </td></tr></table>		<table border="1"><tr><td> </td></tr></table>																		
Zone Type	Zone Pulse Count	Zone Pulse Count Time	Zone Option 1																					
			Zone Option 2																					
			Report Code																					
			Dialler Options																					

Zones 1 – 8 may be programmed as any zone type.

Zone Types

There are thirteen different zone types to choose from. Refer to the table below for the different zone types available.

<i>Zone Type</i>	<i>Description</i>	<i>Zone Type</i>	<i>Description</i>
0	Instant	8	24 Hour Hold-Up
1	Handover	9	24 Hour Tamper
2	Delay-1	10	Reserved
3	Delay-2	11	Keyswitch
4	Reserved	12	24 Hour Burglary
5	Reserved	13	24 Hour Fire
6	24 Hour Medical	14	Chime Only
7	24 Hour Panic	15	Zone Not Used

Table 79: Zone Types

Instant Zone

- 0 An Instant zone (Contact ID Event Code 130) will sound the sirens and operate the dialler as soon as it registers as unsealed after the exit timer has expired.

If an Instant zone has not restored at the time the system is disarmed, a zone restore report will be automatically sent to the receiving party.

Handover Zone

- 1 A Handover zone (Contact ID Event Code 130) will act as an instant zone if it has been triggered by itself. If a handover zone has triggered after a delay zone, the remaining delay time will handover from the delay zone to the handover zone. Handover may be sequential or non-sequential. The control panel is factory default with sequential handover. Refer to Option 8 in "LOCATION 438" on page 229 if you require handover to be non-sequential.

If a Handover zone has not restored at the time the system is disarmed, a zone restore report will be automatically sent to the receiving party.

Delay-1 Zone

- 2 A Delay-1 zone (Contact ID Event Code 130) will have a delay time determined by the value in Entry Timer 1 on page 216. After entry time has expired, the system will activate into alarm condition.

If a Delay-1 zone has not restored at the time the system is disarmed, a zone restore report will be automatically sent to the receiving party.

Delay-2 Zone

- 3 A Delay-2 zone (Contact ID Event Code 130) will have a delay time determined by the value in Entry Timer 2 on page 216. After entry time has expired, the system will activate into alarm condition.

If a Delay-2 zone has not restored at the time the system is disarmed, a zone restore report will be automatically sent to the receiving party.

Reserved

- 4

- 5 *Reserved*
- 6 *24 Hour Medical*
A 24-Hour Medical zone (Contact ID Event Code 100) is always ready to trigger the dialler, horn speaker, bell and strobe regardless of whether the system is in the armed or disarmed state. A medical report will be sent to the base station receiver. A 24-Hour Medical zone will not send a restore report until the zone actually restores.
- 7 *24 Hour Panic*
A 24-Hour Panic zone (Contact ID Event Code 120) is always ready to trigger the dialler, horn speaker, bell and strobe regardless of whether the system is in the armed or disarmed state. A panic report will be sent to the base station receiver. A 24-Hour Panic zone will not send a restore report until the zone actually restores.
- 8 *24 Hour Hold-Up*
A 24-Hour Hold-Up zone (Contact ID Event Code 122) is always ready to trigger the dialler, horn speaker, bell and strobe regardless of whether the system is in the armed or disarmed state. If you require the hold-up alarm to be silent, enable Option 4 – Silent Alarm in Zone Options 1 on page 175. A 24-Hour Hold-Up zone will not send a restore report until the zone actually restores.
- 9 *24 Hour Tamper*
A 24-Hour Tamper zone (Contact ID Event Code 137) is always ready to trigger the dialler, horn speaker, bell and strobe regardless of whether the system is in the armed or disarmed state. A 24-Hour Tamper zone will not send a restore report until the zone actually restores.
- 10 *Reserved*
- 11 *Keyswitch Zone*
A Keyswitch zone is used when you need to connect a keyswitch to operate the system. Refer to Keyswitch Zone Options on page 177 for selecting options such as momentary, toggle etc. User code number 16 will be reported when arming and disarming using this method of operation. Programming the polarity level of user code 16 will also effect the operation of the keyswitch zone. Refer to User Code Priority on page 161 for more information.
- 12 *24 Hour Burglary Zone*
A 24-Hour Burglary zone (Contact ID Event Code 133) is always ready to trigger the dialler, horn speaker, bell and strobe regardless of whether the system is in the armed or disarmed state. A 24-Hour Burglary zone will not send a restore report until the zone actually restores.
- 13 *24 Hour Fire Zone*
A 24-Hour Fire zone (Contact ID Event Code 110) is always ready to trigger the dialler, horn speaker, bell and strobe regardless of whether the system is in the armed or disarmed state. A distinct fire sound is emitted through the horn speaker to indicate this type of alarm condition. This fire sound is completely different to the burglary sound. A 24-Hour Fire zone will not send a restore report until the zone actually restores.

Chime Zone

- 14 A Chime zone is not a burglary zone. It can never sound the sirens or trigger the dialler. Its purpose is to map it to a programmable output for an indication of sealed or unsealed state. Refer to Output Event Type - Global Chime on page 208.

Chime zones require EOL resistors and they will register at a remote codepad. These zones do not effect the operation of forced arming.

Zone Not Used

- 15 If a zone is not used, program it as a zone type of 15. This zone will never sound the sirens or trigger the dialler. An EOL resistor is not required if this zone type is used.

Zone Pulse Count

Zone pulse count is the number of times a zone must be triggered before the zone registers as an alarm. The number of pulses vary between 0 – 15. The zone pulse count value is relative to the time frame (i.e.. The number of pulses must be present during a particular time frame. Refer to “Table 81: Zone Pulse Count Times” on page 174 for time frame settings.

<i>Option</i>	<i>Number Of Pulses</i>	<i>Option</i>	<i>Number Of Pulses</i>
0	1	8	8
1	1	9	9
2	2	10	10
3	3	11	11
4	4	12	12
5	5	13	13
6	6	14	14
7	7	15	15

Table 80: Number Of Pulses



Zones that have been programmed with pulse count which are continuously unsealed for 10 seconds will activate an alarm condition. 24 Hour Fire zones that have been programmed with pulse count which are continuously unsealed for 30 seconds will activate an alarm condition.

Zone Pulse Count Handover

Zone pulse count handover will only operate with zone pulse count time options 8 – 15. Refer to Zone Pulse Count Time on page 174 for more information.

Any zone that registers one trigger pulse will automatically increment any other zone pulse count that has already registered at least one trigger pulse during its respective time. To enable this option, refer to Option 4 in “LOCATION 438” on page 229.



24-Hour zones do not receive any handover pulses from other zones. 24-Hour zones may handover pulses to other zones.

Zone Pulse Count Time

Zone pulse count time is the time frame or period over which the programmed number of pulses must register before an alarm condition is generated.

<i>20 ms Loop Response Time</i>		<i>150 ms Loop Response Time</i>	
<i>Option</i>	<i>Pulse Count Time</i>	<i>Option</i>	<i>Pulse Count Time</i>
0	0.5 Seconds	8	20 Seconds
1	1 Second	9	30 Seconds
2	2 Seconds	10	40 Seconds
3	3 Seconds	11	50 Seconds
4	4 Seconds	12	60 Seconds
5	5 Seconds	13	90 Seconds
6	10 Seconds	14	120 Seconds
7	15 Seconds	15	200 Seconds

Table 81: Zone Pulse Count Times

For zone pulse count time, options 0 – 7 have a zone loop response time of 20 ms. For zone pulse count time, options 8 – 15 have a zone loop response time of 150 ms. Loop response time is the length of time a zone must be unsealed before it can register as a valid pulse.

Inertia sensors should use options 0 - 7, while PIR detectors should use options 8 – 15.



24-Hour zones do not receive any handover pulses from other zones. 24-Hour zones may handover pulses to other zones.

Zone Options 1

When programming this location, you will notice that there are four options per location. You may select one, two, three or all four of these options, however, only one number needs to be programmed. This number is calculated by adding the option bit numbers together. Program a seven (7) if you require options 1, 2 and 4 simultaneously (i.e.. $1 + 2 + 4 = 7$).

<i>Option</i>	<i>Description</i>
1	Lockout Siren/Lockout Dialler
2	Delay Alarm Reporting
4	Silent Alarm
8	Sensor Watch

Table 82: Zone Options 1

Lockout Siren & Lockout Dialler

- 1 Lockout means one activation per arming cycle (i.e.. A zone programmed for "Lockout" can only cause the sirens or dialler to operate once).

When the system is next armed, the zone can cause the sirens and dialler to operate once more. Restore signals will be sent when the system has been disarmed.

The *Solution Ultima 844/862/880* control panel performs lockout different to most other control panels in that only the first zone to trigger an alarm condition will be locked out. All other zones that are triggered during the same siren run time will reset when the sirens reset. This prevents an intruder from triggering all zones then waiting for the sirens to stop before re-entering the premises.

Example

All zones are programmed for both lockout siren and dialler. Zone 1 is triggered followed by all other zones causing the sirens to sound and the dialler to report to the base station receiver. Zone 1 will be the only zone that stops reporting to the base station receiver because of the first zone to trigger is locked out. The remaining zones will continue to report if they are triggered again.

Refer to Swinger Shutdown Count For Siren on page 181 to set the number of times the siren will be allowed to activate before it will be locked out and Swinger Shutdown Count For Dialler on page 182 to set the number of times the dialler will activate before lockout will take effect.

Delay Alarm Reporting

- 2 This option will allow the reporting of alarms on selected zones to be delayed to allow the user to enter their code to cancel alarms that are not required to report. All sounding devices (e.g.: horn speaker, strobe and bell outputs) will operate as soon as the alarm condition occurs, but the dialler will not operate until the delay time in "LOCATION 418 – 419" on page 217 has expired.

Silent Alarm

- 4 A zone programmed to be silent will not activate the horn speaker, bell strobe or EDMSAT outputs. The dialler and all other programmable outputs will function as per their particular programming.

Sensor Watch

- 8 Sensor watch gives the control panel the ability to recognise that detection devices may have stopped working. This is a feature that monitors the operation of a zone over a programmed time period. Refer to "LOCATION 420 - 421" on page 218 for programming sensor watch time.

This value determines how many 24 hour periods a zone may remain continuously sealed before it registers as a sensor watch fault. The number of hours required to fulfil these 24-hour periods is only calculated while the system is in the disarmed state. Every time the system is armed in AWAY Mode, STAY Mode 1 or STAY Mode 2, the sensor watch timer pauses calculating. Sensor watch timer will continue calculating the next time the system has been disarmed.

Refer to LOCATION 333 - 334 on page 186 if you wish to disable sensor watch reports.

Example

If the sensor watch time is programmed for two days in a situation where a premises is armed for twelve hours and disarmed for twelve hours each day, it will take four days before a zone can register as a faulty sensor watch zone.

Keyswitch Zone Options

When you select a zone to be a keyswitch input, then the following table relates to the options available to that keyswitch zone. These keyswitch zone options replace Zone Options 1 only for the zones that have been programmed to operate as a keyswitch zone. Keyswitch zones will report as user code 16.

<i>Option</i>	<i>Description</i>
0	Latching Arm and Disarm In AWAY Mode
1	Latching Arm In AWAY Mode
2	Latching Disarm From AWAY Mode, STAY Mode 1 Or STAY Mode 2
4	Latching Arm and Disarm In STAY Mode 1
5	Latching Arm In STAY Mode 1
8	Momentary Arm and Disarm In AWAY Mode
9	Momentary Arm In AWAY Mode
10	Momentary Disarm From AWAY Mode, STAY Mode 1 Or STAY Mode 2
12	Momentary Arm and Disarm In STAY Mode 1
13	Momentary Arm In STAY Mode 1

Table 83: Keyswitch Zone Options

Latching Arm and Disarm In AWAY Mode

- 0 If this option has been selected, the system will either arm or disarm from AWAY Mode when using the latching keyswitch input.

Latching Arm In AWAY Mode

- 1 If this option has been selected, the system will arm in AWAY Mode when using the latching keyswitch input. Disarming the system will not be permitted via the keyswitch zone if this option has been selected.

Latching Disarm From AWAY Mode, STAY Mode 1 Or STAY Mode 2

- 2 If this option has been selected, the system will disarm from AWAY Mode, STAY Mode 1 or STAY Mode 2 when using the latching keyswitch input. Arming the system will not be permitted via the keyswitch zone if this option has been selected.

Latching Arm and Disarm In STAY Mode 1

- 4 If this option has been selected, the system will arm or disarm in STAY Mode 1 when using the latching keyswitch input. Arming and disarming the system in AWAY Mode will not be permitted via the keyswitch zone if this option has been selected.

Latching Arm In STAY Mode 1

- 5 If this option has been selected, the system will arm in STAY Mode 1 when using the latching keyswitch input. Arming the system in AWAY Mode or disarming the system will not be permitted via the keyswitch zone if this option has been selected.

Latching Disarm From STAY Mode 1 Or STAY Mode 2

- 6 If this option has been selected, the system will only disarm from STAY Mode 1 or STAY Mode 2 when using the latching keyswitch input. Arming the system in STAY Mode 1, STAY Mode 2 or arming and disarming the system in AWAY Mode will not be permitted via the keyswitch zone if this option has been selected.

Momentary Arm and Disarm In AWAY Mode

- 8 If this option has been selected, the system will either arm or disarm from AWAY Mode when using the momentary keyswitch input.

Momentary Arm In AWAY Mode

- 9 If this option has been selected, the system will arm in AWAY Mode when using the momentary keyswitch input. Disarming the system will not be permitted via the keyswitch zone if this option has been selected.

Momentary Disarm From AWAY Mode, STAY Mode 1 Or STAY Mode 2

- 10 If this option has been selected, the system will disarm from either AWAY Mode, STAY Mode 1 or STAY Mode 2 when using the momentary keyswitch input. Arming the system will not be permitted via the keyswitch zone if this option has been selected.

Momentary Arm and Disarm In STAY Mode 1

- 12 If this option has been selected, the system will arm or disarm in STAY Mode 1 when using the momentary keyswitch input. Arming and disarming the system in AWAY Mode will not be permitted via the keyswitch zone if this option has been selected.

Momentary Arm In STAY Mode 1

- 13 If this option has been selected, the system will arm in STAY Mode 1 when using the momentary keyswitch input. Arming the system in AWAY Mode or disarming the system will not be permitted via the keyswitch zone if this option has been selected.

Momentary Disarm From STAY Mode 1 Or STAY Mode 2

- 14 If this option has been selected, the system will only disarm the system from STAY Mode 1 or STAY Mode 2 when using the momentary keyswitch input. Arming the system in STAY Mode 1, STAY Mode 2 or arming and disarming the system from AWAY Mode will not be permitted via the keyswitch zone if this option has been selected.

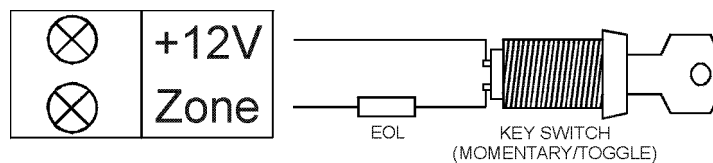

Figure 10: Wiring Diagram For Keyswitch Zone

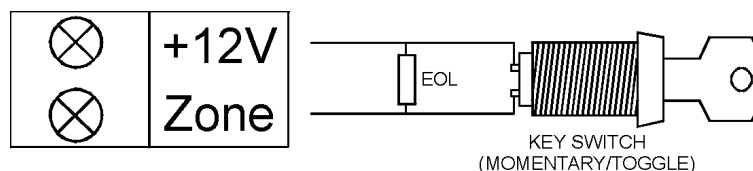

Figure 11: Wiring Diagram For Keyswitch Zone Using Split EOL With Tamper (Location 266 = 14)

Zone Options 2

When programming this location, you will notice that there are four options per location. You may select one, two, three or all four of these options, however, only one number needs to be programmed. This number is calculated by adding the option bit numbers together. Program a seven (7) if you require options 1, 2 and 4 simultaneously (i.e.. $1 + 2 + 4 = 7$).

<i>Option</i>	<i>Description</i>
1	Isolate In STAY Mode 1
2	Zone Isolation Allowed
4	Forced Arming Allowed
8	Zone Restore Report

Table 84: Zone Options 2

Isolate In STAY Mode 1

- 1** If this option has been selected, it will allow the zone to be automatically isolated when the system has been armed in STAY Mode 1.

If this option is not selected, when the system has been armed in STAY Mode 1, the zone will activate an alarm when triggered as it normally would in AWAY Mode.

Refer to Entry Guard Timer For STAY Mode on page 217 if you wish to program a global entry time for ALL zones except for 24-hour zone types when armed in STAY Mode 1 (i.e.. The entry guard timer will override the delay time programmed for a delay zone). If the entry guard timer has been programmed as "0" each zone will act as per its programmed zone type.

Refer to Arming The System In STAY Mode 1 on page 42 for more information.

Zone Isolation Allowed

- 2** If this option has been selected, it will allow a user to isolate the zone before arming the system. If this option is not selected, the zone can not be manually isolated. When a zone has been manually isolated, a zone bypass report will be sent. Refer to Isolating Zones on page 48 for more information.

When isolating 24-hour zone types, the 24-hour zone will automatically send a zone bypass report at the time the zone is selected to be isolated. All non 24-hour zone types will only send a bypass report at the time the system is armed.

If you require the system not to report zone bypass reports, program "LOCATION 329 - 330" on page 185 as zeros.

Forced Arming Allowed

- 4** If this option has been selected, it will allow the system to be armed with the zone unsealed. If this option is not selected, the system will not allow the user code holder to arm the system until the zone in question has been sealed or manually isolated. Refer to Isolating Zones on page 48 for more information.

Zone Restore Report

- 8** If this option has been selected, the zone will send restore reports as soon as the zone has restored. If this option has not been selected, the zone will not send restore reports after the zone has restored.

If a non 24-hour zone has not restored at the time the system is disarmed, the system will automatically send a zone restore report for that zone. All 24-hour zone types will only a send zone restore report at the time the zone has restored.

Zone Reporting Information

Zone Report Code

If you wish the control panel to send zone alarm reports, this location should be programmed as 1. If you do not wish to send zone alarm reports, this location should be programmed as a 0.

Zone Dialler Options

This location is factory default to report only to Receiver 1. You can select each zone to report on Receiver 1, Receiver 2, both Receiver 1 and Receiver 2, Receiver 2 only when Receiver 1 fails or no reporting at all. Select the required dialler option from the table below.

<i>Option</i>	<i>Description</i>
0	No Report Required
1	Receiver 1
2	Receiver 2
4	Receiver 1 and Receiver 2
8	Receiver 2 Only When Receiver 1 Fails

Table 85: Zone Dialler Options

LOCATION 323**3**

<i>Location</i>	<i>Description</i>
323	Swinger Shutdown Count For Siren (0 - 15)

Table 86: Swinger Shutdown Count For Siren Location

This location determines the number of times the sirens can be triggered before any lockout options will take effect. A minimum of one zone must be programmed for lockout siren for this location to be effective. Refer to Zone Options 1 on page 175 to program zones for lockout siren.

Only alarms triggered from zone inputs will increment the swinger shutdown counter. This means alarms such as codepad panic, access denied and any other system alarms will not effect the swinger shutdown count.

While the sirens are operating, the counter for the sirens is only incremented by the first zone that causes the alarm. Any other zones that are triggered during siren run time will not effect the counter. While the dialler is on line, its counter is only incremented by the first zone that causes the alarm. Any other zones that are triggered while the dialler is on line will not effect the counter.

When the swinger shutdown count (As programmed in "LOCATION 323") has been reached, all zones that have been triggered will be locked out according to their individual lockout settings.

Example

All eight zones have been programmed for lockout siren with a swinger shutdown count of 3. If zone 1 triggers an alarm, the swinger shutdown count will decrement by one after the end of siren run time to a swinger shutdown count of 2.

After the siren run time has reset from the previous alarm, zone 2 triggers an alarm and reactivates the sirens. After the sirens have reset, the swinger shutdown count has decremented again from 2 to 1.

If zone 3 also triggers an alarm after the sirens have reset from zone 2, the swinger shutdown count has decremented from 1 to 0, therefore locking out all three zones from sounding the sirens again until the system has been reset.

However, at this point in time, the swinger shutdown count for sirens has again a lockout count of 3 and the process of swinger shutdown for the remaining zones begin again until all zones have been locked out.



The Swinger Shutdown Count For Siren is global to both Area 1 and Area 2 when using a *Solution Ultima 880* control panel that has been partitioned.

LOCATION 324

6

<i>Location</i>	<i>Description</i>
324	Swinger Shutdown Count For Dialler (0-15)

Table 87: Swinger Shutdown Count For Dialler Location

This location determines the number of times the dialler can be triggered before any lockout options will take effect. A minimum of one zone must be programmed for lockout dialler for this location to be effective. Refer to Zone Options 1 on page 175 to program zones for lockout dialler.

Only alarms triggered from zone inputs will increment the swinger shutdown counter. This means alarms such as codepad panic, code retries and any other system alarms will not effect the swinger shutdown count.

While the sirens are operating, the counter for the dialler is only incremented by the first zone that causes the alarm. Any other zones that are triggered during siren time will not effect the counter. While the dialler is on line, its counter is only incremented by the first zone that causes the alarm. Any other zones that are triggered while the dialler is on line will not effect the counter.

When the swinger shutdown count (As programmed in "LOCATION 324") has been reached, all zones that have been triggered will be locked out according to their individual lockout settings.



If "Lockout Dialler" has been enabled for any zone, the last restore signal will not be sent until the system or area (if partitioned) has been disarmed.

The Swinger Shutdown Count For Dialler is global to both Area 1 and Area 2 when using a Solution Ultima 880 control panel that has been partitioned.

Example

All eight zones have been programmed for lockout dialler with a swinger shutdown count of 6. If zone 1 triggers an alarm, the swinger shutdown count will decrement by one at the time the control panel makes the call to a swinger shutdown count of 5.

If zone 1 re-triggers the dialler, the swinger shutdown count will be decremented by one to a swinger shutdown count of 4. If zone 1 re-triggers the dialler 3 more times, the swinger shutdown count will be 1.

If zone 2 triggers an alarm, the swinger shutdown count will be decremented by one to a swinger shutdown count of zero, therefore, locking out zone 2 from activating the dialler again until the system has been reset. However, at this point in time, the swinger shutdown count for the dialler has again a lockout count of 6 and the process of swinger shutdown for the remaining zones including zone 1 begin again until all zones have been locked out.

System Reporting Information

Reporting Information

This section covers features that are involved with the basic house keeping of the system. This includes monitoring of the zones - whether they are isolated from the system or more importantly that they are actually operating, the status of both the AC mains and DC power to the system and codepad generated alarms activated by the user.

Zone Status – Zone Tamper Report

LOCATION 325 - 326



<i>Location</i>	<i>Description</i>
325	Zone Tamper Report
326	Zone Tamper Restore Report

Table 88: Zone Status – Zone Tamper Report Locations

A “Zone Tamper” report (Contact ID Event Code 144) will be sent when the zone loop using split EOL resistors (3K3/6K8) with tamper (1K) becomes open circuit. Refer to Option 14 in LOCATION 266 on page 166 for more information.

If you want zone tamper and zone tamper restore reports, program the two locations with any digit between 1 – 15.

Zone Status – Walk Test Report

LOCATION 327 - 328



<i>Location</i>	<i>Description</i>
327	Walk Test Report
328	Walk Test Restore Report

Table 89: Zone Status – Walk Test Report Locations

A “Walk Test” report (Contact ID Event Code 607) will be sent when either the installer or Master Code holder enters walk test mode. Refer to Walk Test Mode on page 74 when using the Installer Code or Walk Test Mode on page 90 when using the Master Code for more information.

If you want walk test and walk test restore reports, program the two locations with any digit between 1 – 15.

*Zone Status – Bypass Reports***LOCATION 329 - 330**

98

<i>Location</i>	<i>Description</i>
329	Zone Bypass Report
330	Zone Bypass Restore Report

Table 90: Zone Status - Bypass Report Locations

A zone is bypassed when it is manually isolated. Refer to Isolating Zones on page 48 for information on isolating zones. A "Zone Bypass" report (Contact ID Event Code 573) will be sent at the end of exit time for any zone that has been manually isolated. 24-hour zones will send a "Zone Bypass" report at the time the zone has been selected to be isolated.

A "Zone Bypass Restore" report will be sent when the system has been disarmed. All bypassed zones are automatically cleared when the system has been disarmed.

The bypass code parameter is used as the expansion digit in 4+2 Formats. It has no effect on Contact ID Format as a zone bypass will always be reported on event code 570.



If "Zone Bypass" reports are not required, program "LOCATION 329 - 330" with a zero.

Contact ID Event Code 572 will report when any 24-Hour burglary zones have been manually bypassed. Contact ID Event Code 571 will report when any 24-Hour fire zones have been manually isolated.

*Zone Status – Trouble Reports***LOCATION 331 – 332**

23

<i>Location</i>	<i>Description</i>
331	Zone Trouble Report
332	Zone Trouble Restore Report

Table 91: Zone Status - Trouble Report Locations

A zone is in trouble when it is unsealed at the end of exit time. A "Sensor Trouble" report (Contact ID Event Code 380) will be sent to indicate that one or more zones have been automatically isolated by the system. 24-hour zones that are unsealed at the end of exit time will not send a "Sensor Trouble" report as the restore for that zone is still outstanding.

A "Sensor Trouble" restore report will be sent for burglary zones when the zone reseals or when the system is next disarmed (which ever happens first). A 24-hour zone will only send a restore signal when it has resealed.

The trouble code parameter is used as the expansion digit in 4+2 Format. It has no effect on Contact ID Format as a "Sensor Trouble" report will always be reported on event code 380.



If "Sensor Trouble" reports are not required, program "LOCATION 331 – 332" with a zero.

Zone Status – Sensor Watch Reports**LOCATION 333 - 334****45**

<i>Location</i>	<i>Description</i>
333	Sensor Watch Report
334	Sensor Watch Restore Report

Table 92: Zone Status – Sensor Watch Report Locations

A "Self Test Failure" report (Contact ID Event Code 307) will be sent to the base station receiver when a zone has not been triggered during the Sensor Watch Time programmed in "LOCATION 420 - 421" on page 218. This report will continue to be sent (according to the frequency of the sensor watch time) until the fault has been rectified.

To clear the fault and stop any further reporting, the zone that registered the fault must be unsealed and resealed again. Refer to "LOCATION 420 - 421" on page 218 to set the number of days a zone may remain sealed before registering as a fault. Refer to Zone Options 1 on page 175 to program zones to be monitored by the sensor watch feature.



If "Self Test Failure" reports are not required, program "LOCATION 333 - 334" with a zero.

Zone Status – Alarm Restore Code**LOCATION 335****14**

If you wish the control panel to send zone alarm restore reports, this location should be programmed as 14. If you do not wish to send zone restore reports, this location should be programmed as a zero.

"LOCATION 336" will be ignored when programming the alarm restore code and is global for all zones. A zone restore report will only report to the receiving party that the zone has been allocated to (e.g.: Receiver 1 or Receiver 2 etc).

Zone Status Reporting Options**LOCATION 336****1**

<i>Option</i>	<i>Description</i>
0	No Report Required
1	Receiver 1
2	Receiver 2
4	Receiver 1 and Receiver 2
8	Receiver 2 Only When Receiver 1 Fails

Table 93: Zone Status Reporting Options Location

This location is factory default to report only to Receiver 1. You can select whether the zone status reports will report on, Receiver 1, Receiver 2, both Receiver 1 and Receiver 2, Receiver 2 only when Receiver 1 fails or no reporting at all.

When using partitioned *Solution Ultima 880* control panels, this location will be ignored if Option 1 – Lock Area 1 to Receiver 1 & Lock Area 2 to Receiver 2 in "LOCATION 445" on page 242 has been programmed.

RF Supervision Time**LOCATION 337**

<i>Location</i>	<i>Description</i>
337	Increments Of 6 Hours (0 – 90 Hours)

Table 94: Zone Status – RF Supervision Time Location

A "RF Supervision Failure" report (Contact ID Event Code 307) will be sent to the base station receiver when the wireless receiver has not received a signal from any RF wireless zone during the RF Supervision Time. This report will continue to be sent (according to the frequency of the RF Supervision Time) until the fault has been rectified.

To clear the fault and stop any further reporting, the zone that registered the fault must be unsealed and resealed again. Refer to Fault Descriptions on page 53 for more information.



If "RF Supervision Time" reports are not required, program "LOCATION 337" with a zero.

RF Low Battery Report**LOCATION 338 - 339****68**

<i>Location</i>	<i>Description</i>
338	RF Low Battery Report
339	RF Low Battery Restore Report

Table 95: RF Low Battery Report Locations

A "RF Low Battery" report (Contact ID Event Code 384) will be sent to the base station receiver when the battery voltage on a wireless zone falls below approximately 2.4V DC. An "RF Low Battery Restore" report will be sent on the first valid signal after the battery has been replaced.

RF Receiver Trouble Report**LOCATION 340 - 341****79**

<i>Location</i>	<i>Description</i>
340	RF Receiver Trouble Report (Tens Digit)
341	RF Receiver Trouble Report (Units Digit)

Table 96: RF Receiver Trouble Report Locations

A “RF Receiver Trouble” report (Contact ID Event Code 355) will be sent to the base station receiver when the RF receiver registers one of the following events:

RF Signal Jamming	- Point ID Code 001
RF Receiver Tamper Switch	- Point ID Code 002
RF Receiver Failure	- Point ID Code 003.

RF Receiver Trouble Restore Report**LOCATION 342 - 343****7** 11

<i>Location</i>	<i>Description</i>
342	RF Receiver Trouble Report (Tens Digit)
343	RF Receiver Trouble Report (Units Digit)

Table 97: RF Receiver Trouble Report Locations

A “RF Receiver Trouble Restore” report will be sent to the base station receiver when the RF receiver no longer registers RF Signal Jamming, RF Receiver Tamper Switch or RF Receiver Failure.

RF Dialler Options**LOCATION 344****1**

<i>Option</i>	<i>Description</i>
0	No Report Required
1	Receiver 1
2	Receiver 2
4	Receiver 1 and Receiver 2
8	Receiver 2 Only When Receiver 1 Fails

Table 98: Zone Status Reporting Options Location

This location is factory default to report only to Receiver 1. You can select whether the zone status reports will report on, Receiver 1, Receiver 2, both Receiver 1 and Receiver 2, Receiver 2 only when Receiver 1 fails or no reporting at all.

LOCATION 345 - 346

11 12

<i>Location</i>	<i>Description</i>
345	Opening Report
346	Closing Report

Table 99: Open/Close Reporting Locations

An "Opening" report (Contact ID Event Code 401) will be sent to the base station receiver when the system has been disarmed from AWAY Mode. A "Closing" report (Contact ID Event Code 401) is sent at the end of exit time when the system has been armed in AWAY Mode.

If an expanded format has been selected, this code will be used as the expansion code and the user number that armed or disarmed the system will follow in the same transmission.

Refer to Option 2 in "LOCATION 178" on page 154 for programming "Open/Close" reports in STAY Mode. To program "Open/Close" reports only after a previous alarm, refer to Option 1 in "LOCATION 178" on page 154.



If you do not require "Open/Close" reports, program "LOCATION 345 - 346" with zero.

Solution Ultima 880 control panels that have been partitioned will send Open/Close reports with a Contact ID Event Code 402

LOCATION 347

1

<i>Option</i>	<i>Description</i>
0	No Report Required
1	Receiver 1
2	Receiver 2
4	Receiver 1 and Receiver 2
8	Receiver 2 Only When Receiver 1 Fails

Table 100: Open/Close Reporting Options Location

This location is factory default to report only to Receiver 1. You can select whether the open/close reports will report on Receiver 1, Receiver 2, both Receiver 1 and Receiver 2, Receiver 2 only when Receiver 1 fails or no reporting at all.

Codepad Duress Report

LOCATION 348

6

<i>Location</i>	<i>Description</i>
348	Codepad Duress Report

Table 101: Codepad Duress Report Location

A "Duress" report (Contact ID Event Code 121) will be sent to the base station receiver when the 9 button is added to the end of any valid user code being used to disarm the system. This alarm will always be silent. A duress alarm can be triggered during exit time (i.e.. If the system has been armed and then disarmed by adding the 9 button to the end of the user code before exit time has expired, a "Duress" report will be sent). Adding 9 to the end of a user code when arming the system will not cause a duress alarm.

Refer to Option 2 in "LOCATION 442" on page 233 if you wish to add the 3 button to the end of the user code being used to disarm the system.



Restore reports are not sent for this event. If a "Duress" report is not required, program "LOCATION 348" with a zero.

Codepad Panic Report

LOCATION 349 - 350

7 15

<i>Location</i>	<i>Description</i>
349	Codepad Panic Reporting Code (Tens Digit)
350	Codepad Panic Reporting Code (Units Digit)

Table 102: Codepad Panic Report Locations

A "Panic Alarm" report (Contact ID Event Code 120) will be sent to the base station receiver when either the two outside buttons 1 and 3 or **STAY** and **AWAY** are pressed simultaneously. This is an audible alarm. Refer to Option 1 in "LOCATION 437" on page 228 if you require codepad panic to be silent.



Restore reports are not sent for this event. If a "Panic" report is not required, program "LOCATION 349 - 350" with a zero.

Codepad Fire Report**LOCATION 351 - 352****7** **14**

<i>Location</i>	<i>Description</i>
351	Codepad Fire Reporting Code (Tens Digit)
352	Codepad Fire Reporting Code (Units Digit)

Table 103: Codepad Fire Report Locations

A "Fire Alarm" report (Contact ID Event Code 110) will be sent to the base station receiver when the **4** and **6** buttons are pressed simultaneously. This is an audible alarm. Refer to Option 2 in "LOCATION 437" on page 228 if you require codepad fire to be silent. A distinct fire sound is emitted through the horn speaker to indicate this type of alarm condition. The fire sound is different to the burglary sound.



Restore reports are not sent for this event. If a "Fire" report is not required, program "LOCATION 351 - 352" with a zero.

Codepad Medical Report**LOCATION 353 - 354****7** **13**

<i>Location</i>	<i>Description</i>
353	Codepad Medical Reporting Code (Tens Digit)
354	Codepad Medical Reporting Code (Units Digit)

Table 104: Codepad Medical Report Locations

A "Medical" report (Contact ID Event Code 100) will be sent to the base station receiver when the **7** and **9** buttons are pressed simultaneously. This is an audible alarm. Refer to Option 4 in "LOCATION 437" on page 228 if you require codepad medical to be silent.



Restore reports are not sent for this event. If a "Medical" report is not required, program "LOCATION 353 - 354" with a zero.

Codepad Reporting Options**LOCATION 355****1**

<i>Option</i>	<i>Description</i>
0	No Report Required
1	Receiver 1
2	Receiver 2
4	Receiver 1 and Receiver 2
8	Receiver 2 Only When Receiver 1 Fails

Table 105: Codepad Reporting Options Location

This location is factory default to report only to Receiver 1. You can select whether the codepad reporting options will report on Receiver 1, Receiver 2, both Receiver 1 and Receiver 2, Receiver 2 only when Receiver 1 fails or no reporting at all.

System Status – Fuse Fail Report**LOCATION 356 - 357****10** **3**

<i>Location</i>	<i>Description</i>
356	System Status – Fuse Fail Reporting Code (Tens Digit)
357	System Status – Fuse Fail Reporting Code (Units Digit)

Table 106: System Status – Fuse Fail Report Locations

A system trouble report (Contact ID Event Code 300) will be sent when either the codepad fuse or the accessories fuse has blown. A delay of approximately 10 seconds will be between from when the fuse has blown and when the system will report the event.

System Status – Fuse Fail Restore Report**LOCATION 358 - 359****10** **8**

<i>Location</i>	<i>Description</i>
358	System Status – Fuse Fail Restore Reporting Code (Tens Digit)
359	System Status – Fuse Fail Restore Reporting Code (Units Digit)

Table 107: System Status – Fuse Fail Restore Report Locations

A system trouble restore report (Contact ID Event Code 300) will be sent when either the codepad fuse or the accessories fuse has been replaced. A delay of approximately 10 seconds will be between from when the fuse has been replaced and when the system will report the event.

System Status – AC Fail Report**LOCATION 360 - 361****10** 2

<i>Location</i>	<i>Description</i>
360	System Status – AC Fail Reporting Code (Tens Digit)
361	System Status – AC Fail Reporting Code (Units Digit)

Table 108: System Status – AC Fail Report Locations

An "AC Loss" report (Contact ID Event Code 301) will be sent to the base station receiver when the AC mains supply has been disconnected continuously for two minutes. If you require an "AC Loss" report to be sent to the base station receiver when the AC mains supply has been disconnected for 1 hour, enable Option 1 in "LOCATION 438" on page 229. If you wish to ignore AC fail, enable Option 2 in "LOCATION 438" on page 229.



If an "AC Loss" report is not required, program "LOCATION 360 - 361" with a zero.

System Status – AC Fail Restore Report**LOCATION 362 - 363****10** 7

<i>Location</i>	<i>Description</i>
362	System Status – AC Fail Restore Reporting Code (Tens Digit)
363	System Status – AC Fail Restore Reporting Code (Units Digit)

Table 109: System Status – AC Fail Restore Report Locations

A restore signal will be sent when the AC mains supply has been restored continuously for more than two minutes.



If an "AC Loss" restore report is not required, program "LOCATION 362 - 363" with a zero.

System Status - Low Battery Report**LOCATION 364 - 365****10** 1

<i>Location</i>	<i>Description</i>
364	System Status – Low Battery Reporting Code (Tens Digit)
365	System Status – Low Battery Reporting Code (Units Digit)

Table 110: System Status – Low Battery Report Locations

A "Battery Test Failure" report (Contact ID Event Code 309) will be sent to the base station receiver when the systems battery voltage falls below 10.5 volts or when a dynamic battery test detects a low capacity battery.

A dynamic battery test is performed every time the system has been armed as well as every four hours from power up of the control panel. Refer to Fault Descriptions on page 53 for more information.



If a "Low Battery" report is not required, program "LOCATION 364 - 365" with a zero.

Outputs 1 – 4 will NOT operate whilst the control panel detects a low battery.

System Status - Low Battery Restore Report**LOCATION 366 - 367****10** 6

<i>Location</i>	<i>Description</i>
366	System Status – Low Battery Restore Report (Tens Digit)
367	System Status – Low Battery Restore Report (Units Digit)

Table 111: System Status – Low Battery Restore Report Locations

A "Low Battery" restore report will be sent if the back up battery has been restored the next time the system has been armed, or when the next dynamic battery test reports the battery test is OK.



If a "Low Battery Restore" report is not required, program "LOCATION 366 - 367" with a zero.

LOCATION 368 - 370

6 7 12

<i>Location</i>	<i>Description</i>
368	Code Retries (0 – 15)
369	System Status – Access Denied Reporting Code (Tens Digit)
370	System Status – Access Denied Reporting Code (Units Digit)

Table 112: System Status – Access Denied Locations

An "Access Denied" report (Contact ID Event Code 421) will be sent to the base station receiver when the number of incorrect code attempts equals the number programmed in "LOCATION 368". This is an audible alarm. Refer to Option 8 in "LOCATION 437" on page 228 if you require this alarm to be silent.



Restore signals for this event are not sent. If an "Access Denied" report is not required, program "LOCATION 369 - 370" with a zero.

Code Retries

Code retries restricts the amount of times an invalid user code can be used in an attempt to operate the system. This location sets the number of incorrect code attempts that will cause an alarm condition. When the number of incorrect code attempts equals the number programmed in this location, the system will carry out the following;

1. Activate the sirens, internal screamers and strobes connected to the control panel. Refer to Option 8 in "LOCATION 437" on page 228 if you require access denied to be silent.
2. Shutdown all codepads that are connected to the control panel and lock them out for the time period programmed in "LOCATION 422" on page 218.
3. Send an "Access Denied" (Contact ID Event Code 421) report to the base station receiver.

Each time the system is armed or disarmed, the counter will be reset. The number of attempts can be anywhere between 1-15. If you program a zero into "LOCATION 368", the code attempts are unlimited and neither of the three points listed above will take place. This function works when the system is in the armed or disarmed state.

System Status Reporting Options**LOCATION 371**

1

<i>Option</i>	<i>Description</i>
0	No Report Required
1	Receiver 1
2	Receiver 2
4	Receiver 1 and Receiver 2
8	Receiver 2 Only When Receiver 1 Fails

Table 113: System Status Reporting Options Location

This location is factory default to report only to Receiver 1. You can select whether the system status reporting options will report on Receiver 1, Receiver 2, both Receiver 1 and Receiver 2, Receiver 2 only when Receiver 1 fails or no reporting at all.

Test Reporting Time

LOCATION 372 - 378

0000 71 0

<i>Location</i>	<i>Description</i>
372	Actual Hour Of The Day (Tens Digit)
373	Actual Hour Of The Day (Units Digit)
374	Actual Minute Of The Day (Tens Digit)
375	Actual Minute Of The Day (Units Digit)
376	Test Report Code (Tens Digit)
377	Test Report Code (Units Digit)
378	Repeat Interval In Days

Table 114: Test Reporting Time Locations

A "Test" report (Contact ID Event Code 602) is a specific signal that is sent to the base station receiver and is normally used to test the dialling and reporting functions of the control panel. Test reports will not be sent if the Subscriber ID Number is 0000.

When programming test reports, the control panel needs to know the hour and minute of the day the report is required, as well as how often to send the report. Test reports are reported on a daily basis ranging from every day to every fifteen days. Refer to "Set The Number Of Days Until The First Test Report" on page 65 to set the first test report if required.



If you do not require "Test" reports, program the repeat interval in "LOCATION 378" as zero.

V1.05+

Test reports can be sent every 30 minute by programming the test report time as 34:00.

Example

If you wish to send test reports once every seven days at 11:35 PM, you would program "LOCATION 372 - 378" as follows:

2335 71 7

Test Reporting Dialler Options

LOCATION 379

1

<i>Option</i>	<i>Description</i>
0	No Report Required
1	Receiver 1
2	Receiver 2
4	Receiver 1 and Receiver 2
8	Receiver 2 Only When Receiver 1 Fails

Table 115: Test Reporting Options Location

This location is factory default to report only to Receiver 1. You can select whether the test reporting options will report on Receiver 1, Receiver 2, both Receiver 1 and Receiver 2, Receiver 2 only when Receiver 1 fails or no reporting at all.

Programmable Outputs

This section includes the following:

- *Outputs*
- *Output Defaults*
- *Redirecting Outputs To The Codepad Buzzer*
- *Output Event Types*
- *Output Polarity*
- *Timing Of Outputs*
- *Pulsing Polarities*
- *One Shot Polarities*

Outputs

The *Solution Ultima 844/862/880* control panel has four fully programmable outputs on the main PCB and one other programmable output that operates the codepad buzzer. These four outputs are factory default to operate a horn speaker, fire alarm verification, strobe and an internal screamer.



Outputs 1 – 4 will NOT operate whilst the control panel detects a low battery.

Programmable outputs require four parameters to be programmed in order to operate correctly.

Event Type: When To Operate

Polarity: How To Operate

Time Base: How Long To Operate For

Time Multiplier: How Often To Operate

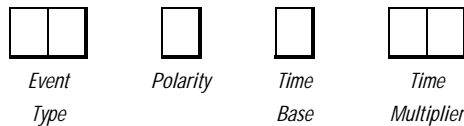

When To Operate Is selected from the output event types listed on page 202. Each digit should be entered into the two corresponding locations for the output event type required.

How To Operate Is selected from "Table 117: Event Type Polarities" on page 211. This determines whether the output remains operating for the duration of the event, pulses for the duration, operates once only (one shot) or latches on.

How Long To Operate For Is determined by a time base and a multiplier. Refer to "Timing Of Outputs" on page 213 for further information.

How Often To Operate For Is determined by a time base and a multiplier. Refer to "Timing Of Outputs" on page 213 for further information.

Output Defaults

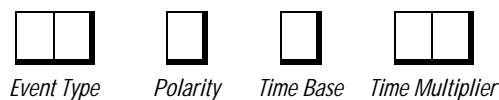
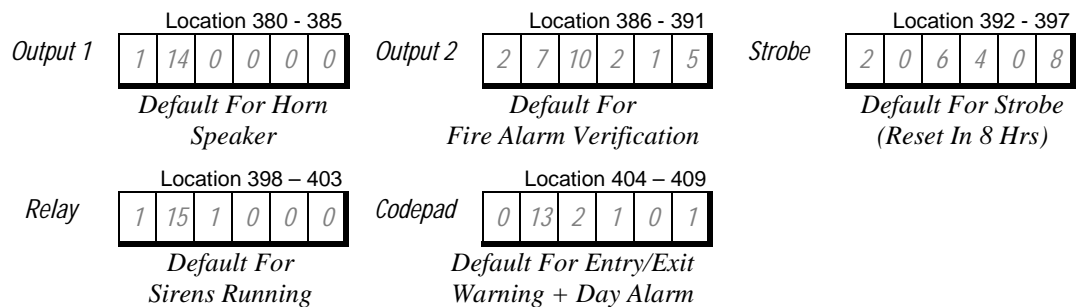

Redirecting Outputs To The Codepad Buzzer

Multiple output event types can be directed to the codepad buzzer so that it may be used to indicate any number of events.

This is achieved by selecting an output and programming it for the required output event type. When you are satisfied that the output is functioning correctly, change the first digit of the output event type (i.e.. The tens digit) by adding the value 8.

Example

30 Communications Failure

This event will operate when the dialler has made all possible attempts to reach the base station receiver. The output will reset when the first "Kiss-Off" is received. This output event type is not applicable for domestic reporting.

To redirect the above output event type to operate a codepad buzzer, program the output event type as below:

110 Communications Failure

This event will operate when the dialler has made all possible attempts to reach the base station receiver. The output will reset when the first "Kiss-Off" is received. This output event type is not applicable for domestic reporting.

The codepad buzzer will now operate instead of the output that has been programmed. The output is no longer functional and cannot be used for any other output event type.

Output Event Types

There are approximately seventy-five different output event types to choose from. Two numbers designate each output event type. These two numbers need to be programmed into the appropriate locations of the output being used to indicate when the output should operate.



All reset times are in reference to polarity 1 and 8. Reset times will vary depending on the polarity used.

- 00 EDMSAT - Satellite Siren (Output 1 Only)**
 This output controls all functions of an EDMSAT satellite siren (SS914). The option of speaker indication beeps will not operate via the EDMSAT for remote operations. No polarity is required to be programmed for this output event type.
- 01 System Armed**
 This output will operate when the system is armed in AWAY Mode, STAY Mode 1 or STAY Mode 2. The output will reset when the system has been disarmed. If the system has been partitioned, this event will operate when both areas have been armed in AWAY Mode or STAY Mode 1.
- 02 System Disarmed**
 This output will operate when the system is in the disarmed state. The output will reset as soon as the system becomes armed. If the system has been partitioned, this event will operate when both areas have been disarmed.
- 03 Armed In STAY Mode**
 This output will operate when the system has been armed in STAY Mode 1 or STAY Mode 2. The output will reset when the system is disarmed. If the system has been partitioned, this event will operate when either area has been armed in STAY Mode 1.
- 04 Armed In AWAY Mode**
 This output will operate when the system has been armed in AWAY Mode. The output will reset when the system is disarmed. If the system has been partitioned, this event will operate when either area has been armed in AWAY Mode.
- 05 Auto Arm Pre-Arming Alert Time**
 This output will operate during the time period before the control panel will automatically arm in AWAY Mode or STAY Mode 1. Once the control panel has automatically armed in AWAY Mode or STAY Mode 1, the output will reset. To program the pre-arming alert time, refer to "LOCATION 425" on page 220.
- 06 Exit Warning With All Zones Sealed Or Entry Warning**
 This output will operate during exit time when the control panel has been armed in AWAY Mode, STAY Mode 1 or STAY Mode 2 if all zones are sealed. This output event type will reset once exit time has expired.

The next time this output event type will operate will be during entry time and will reset once entry time has expired or the system has been disarmed. This output event type will also operate if a zone has triggered when the system has been armed in STAY Mode 1 or STAY Mode 2 only if the Entry Guard Timer For STAY Mode has been programmed in "LOCATION 416 - 417" on page 217.

- 07 Exit Warning**
This output operates during exit time when the system has been armed in AWAY Mode, STAY Mode 1 or STAY Mode 2. The output will reset once exit time has expired.
- 08 Exit Warning Finished**
This output operates when the exit time has expired when the system has been armed in AWAY Mode, STAY Mode 1 or STAY Mode 2. The output will reset when the system has been disarmed.
- 09 Kiss-Off After Exit Time**
This output will operate after the first successful transmission to the base station receiver when exit time has expired. The output will reset when the system has been disarmed.
- 11 Entry Warning**
This output will operate when either Entry Timer 1, Entry Timer 2 or Entry Guard Timer For STAY Mode are operating. The output will reset when the entry time expires.
- 12 Entry Warning + Day Alarm Resetting**
This output combines both Entry Warning and Day Alarm Resetting so that either of these two events will activate the output.
- If the output has been triggered by either Entry Timer 1, Entry Timer 2, or Entry Guard Timer For STAY Mode, the output will reset once the entry timer has expired or the system has been disarmed.
- If a zone programmed for day alarm has triggered during the disarmed state, the output will reset when the zone has resealed. Day alarm may be turned on and off by holding down the **4** button. Refer to Day Alarm Zones on page 164 for programming zones to operate for day alarm.
- 13 Exit Warning + Entry Warning + Day Alarm Resetting**
This output combines exit warning, entry warning and day alarm so that any of these three events will activate the output.
- This output will activate once the system has been armed in AWAY Mode, STAY Mode 1 or STAY Mode 2 irrespective of any zones being sealed or unsealed until exit time expires.
- The next time the output will activate will be during entry time and will reset once entry time has expired or the system has been disarmed. This output will also operate when the Entry Guard Timer For STAY Mode is timing.
- If a zone programmed for day alarm has triggered during the disarmed state, the output will reset when the zone has resealed. Day alarm may be turned on and off by holding down the **4** button. Refer to Day Alarm Zones on page 164 for programming zones to operate for day alarm.
- 14 Day Alarm Resetting**
This output will operate when a zone programmed for day alarm has been triggered. The output will reset when the day alarm zone has resealed. Day alarm may be turned on and off by holding down the **4** button. Refer to Day Alarm Zones on page 164 for programming zones to operate for day alarm.

○ 15

Day Alarm Latching

This output will operate when a zone programmed for day alarm has been triggered. The output will reset when the **AWAY** button has been pressed. Day alarm may be turned on and off by holding down the **4** button. Refer to Day Alarm Zones on page 164 for programming zones to operate for day alarm.

If the control panel has been partitioned, pressing the **AWAY** button on a CP5 Area Addressable codepad other than the zone was allocated, or pressing the **AWAY** button on a CP5 Master Partitioned Codepad will not reset the output. You can only reset this output on the area codepad that the zone has been allocated to.

1 0

Day Alarm Enabled

This output will operate as soon as day alarm has been enabled. The output will reset when day alarm has been turned off.

Day alarm can be turned on and off by holding down the **4** button. Three beeps indicates that day alarm has been turned on, two beeps indicates that day alarm has been turned off. Refer to Day Alarm Zones on page 164 for programming zones to operate for day alarm.

1 1

Telephone Line Fail

This output will operate when the in-built telephone line fault module detects that the telephone line has been disconnected for a period of approximately 40 seconds. The output will reset once the telephone line has been restored continuously for more than 40 seconds. This output will not operate unless Option 1 in "LOCATION 176" on page 149 has been enabled.

1 2

Kiss-Off Received

This output will operate after the control panel has successfully sent to the receiving party.

1 3

Fuse Fail

This output will operate when either the 1 Amp codepad fuse or the 1 Amp accessories fuse fails. The output will reset once the faulty fuse has been replaced.

1 4

AC Fail

This output will operate as soon as the AC mains has failed. The output will reset as soon as the AC mains has restored. This output will operate regardless of Option 2 in "LOCATION 438" on page 229 being set.

1 5

Low Battery

This output will operate when a dynamic battery test detects that the battery has failed or the battery voltage has fallen below 10.5 volts. The dynamic battery test is performed every four hours from when the system has been powered up or every time the system has been armed in AWAY Mode, STAY Mode 1 or STAY Mode 2.

This output will reset only after a dynamic battery test reports the backup battery has restored.

1 6

Horn Speaker Monitor Fail

If Option 2 – Enable Monitoring Of Horn Speaker in "LOCATION 436" on page 227 has been selected, this output will operate when the horn speaker has been disconnected. The output will reset when the horn speaker has been reconnected.

1 7 Sensor Watch Alarm
 This output will operate when the sensor watch count has been reached. Refer to Zone Options 1 on page 175 for more information on programming zones for sensor watch. Refer to "LOCATION 420 - 421" on page 218 for setting how many days before a zone can register as a faulty sensor watch zone.

1 8 Codepad Medical Alarm
 This output will operate when pressing the 7 and 9 buttons simultaneously on the remote codepad has activated a codepad medical alarm. This output will reset once a valid user code has been entered at the remote codepad.

1 9 Codepad Fire Alarm
 This output will operate when a codepad medical alarm has been activated by pressing the 4 and 6 buttons on the remote codepad simultaneously. This output will reset once a valid user code has been entered at the remote codepad.

1 10 Codepad Panic Alarm
 This output will operate when a codepad panic alarm (audible or silent) has been activated by pressing the 1 and 3 buttons or the **STAY** and **AWAY** buttons on the remote codepad simultaneously. This output will reset once a valid user code has been entered at the remote codepad.

1 11 Codepad Duress Alarm
 This output will operate when a duress alarm has been activated by adding a 9 to the end of the user code being used to disarm the system. This output will reset the next time the system has been armed.

1 12 Codepad Tamper – Access Denied
 This output will operate when the wrong code has been entered more times than allowed. Refer to "LOCATION 368 - 370" on page 195 for setting the number of incorrect attempts that may be allowed. This output will reset once a valid user code has been entered.

1 13 Speaker Beeps
 This output will function during all remote radio/keyswitch operations allowing you to fit a 12V DC buzzer or light to provide status indication for the end user. Refer to the table below for the identification beeps and their meanings.

<i>No Of Beeps</i>	<i>System Status</i>
1	System Disarmed
2	System Armed In AWAY Mode
3	System Armed In STAY Mode 1

Table 116: Horn Speaker Beeps

1 14 Horn Speaker (Output 1 Only)
 This output will operate only on Output 1 and should be programmed whenever an 8-ohm horn speaker is required. A maximum of two horn speakers may be used. Refer to "LOCATION 423" on page 219 for setting the siren run time and "LOCATION 424" on page 219 for setting the siren sound rate.

If you require monitoring of the horn speaker, refer to Option 2 in "LOCATION 436" on page 227.

- 1 15 Sirens Running**
This output will operate for the duration of the siren run time programmed in "LOCATION 423" on page 219. When the sirens have been activated, this output will reset once the siren run time has expired. The relay output (Output 4) is factory default for this operation.
- 20 Strobe Operating**
This output will operate when an alarm condition occurs and will reset once a valid user code has been entered. The strobe output (Output 3) is factory default for this operation and is programmed to automatically reset after 8 hours of duration.
- 21 Silent Alarm**
This output will operate when any zone programmed to be silent alarm has triggered. The output will reset when the siren run time expires, an audible alarm has triggered, or a valid user code has been entered. Refer to Zone Options 1 on page 175 to program zones to be silent.
- 22 Alarm When In STAY Mode**
This output will operate whenever an audible or silent zone alarm has triggered when the system has been armed in STAY Mode 1 or STAY Mode 2. The output will reset when the system has been disarmed.
- 23 Alarm When In AWAY Mode**
This output will operate whenever an audible or silent zone alarm has triggered when the system has been armed in AWAY Mode. The output will reset when the system has been disarmed.
- 24 Mimic System Fault**
This output will operate without any time delays as soon as any system fault occurs including if the AC mains supply has failed. The output will reset as soon as the system fault or the AC mains supply has restored.
- 25 Fire Alarm Resetting**
This output will operate when a 24-hour fire zone is triggered. The output will reset once a valid user code has been entered or when siren run time expires. If the control panel has been partitioned, a user code allocated to another area may reset this output.
- 26 Fire Alarm Latching**
This output will operate when a 24-hour fire zone has triggered and will reset when the system has been armed or disarmed. If the system has been partitioned, the output will reset when any area has been armed or disarmed.

27 **Fire Alarm Verification**

This feature is used on some commercial fire control panels to reduce false alarms on smoke detectors. It is conceptually very similar to zone pulse count as used in some motion detectors. Basically, a fire zone is allotted a pulse count of 3 pulses over a period of 3 minutes.

If the smoke detector trips, the voltage to the smoke detector is disconnected for 15 seconds and then reapplied. No alarm has registered.

If within 3 minutes of the first trigger the unit triggers again, no alarm will be registered and the voltage to the smoke detector will again be disconnected for 15 seconds and then reapplied.

If a third trigger is detected within 3 minutes of the first trigger, (i.e.. 3 pulses in 3 minutes) a fire alarm will be registered. Power to the smoke detector will be maintained to facilitate unit identification via the detector memory.

This output should be connected to the negative side of any fire/smoke detector. To configure an output for this feature, use the following settings.

EVENT TYPE = 2,7 POLARITY = 10

TIMEBASE = 2 MULTIPLIER = 15

The zone that the fire/smoke detector is connected to should be programmed as follows:

ZONE TYPE = 13 ZONE PULSE COUNT = 3

ZONE PULSE COUNT TIME = 15

28 **Remote Control 1**

29 **Remote Control 2**

2 **10 Remote Control 3**

These outputs can be remotely activated (Turned "On" or "Off") via the following methods:

1. Remote Codepad - Refer to the Master Code Functions - "Turning Outputs On/Off" on page 87 for further information.
2. Remotely Via Alarm Link Software - Refer to your Alarm Link Instruction Manual for further information.

2 **11 Radio Control Output 1**

This output will operate if you hold down button 3 on the 4-channel hand held Transmitter when the system is armed or disarmed.

2 **12 Radio Control Output 2**

This output will operate if you hold down button 4 on the 4-channel hand held Transmitter when the system is armed or disarmed. If you enable option 8 in LOCATION 436 on page 227, this output will not operate and will only arm the system in STAY Mode 1.

2 **13 Radio Control Output 1 – Not In AWAY Mode**

This output will operate when you hold down button 3 on the 4-channel hand held Transmitter only when the system is disarmed or armed in STAY Mode 1 or STAY Mode 2. The output will not operate when the system is armed in AWAY Mode.

- 2¹⁴ Radio Control Output 2 – Not In AWAY Mode**
 This output will operate when you hold down button 4 on the 4-channel hand held Transmitter only when the system is disarmed or armed in STAY Mode 1 or STAY Mode 2. The output will not operate when the system is armed in AWAY Mode. If you enable option 8 in LOCATION 436 on page 227, this output will not operate and will only arm the system in STAY Mode 1.
- 2¹⁵ Communications Failure After 3 Unsuccessful Calls**
 This output will operate when the communication dialler has made 3 unsuccessful calls to the base station receiver. The output will reset when all messages have been sent (i.e.. When the buffer is empty or when all possible attempts have been made).
- 30 Communications Failure**
 This output will operate when the communication dialler has made all possible attempts to reach the base station receiver. The output will reset when the first "Kiss-Off" has been received. This output will not operate for domestic formats.
- 31 Dialler Disabled**
 This output will operate as long as Option 1 in "LOCATION 177" on page 153 has been disabled. The output will reset once Option 1 – Enable Dialler Reporting Functions in "LOCATION 177" on page 153 has been enabled.
- 32 Dialler Active**
 This output will operate when the communication dialler is on-line. The output will reset when the communication dialler has released the telephone line.
- 33 Ring Detect**
 This output will operate when an incoming call has been detected by the control panel. The output will reset when the ringing has stopped or when the call has been answered.
- 34 Codepad Panic (Multi-Break)**
 (V1.05 +) This output will operate when a panic alarm has been initiated via the codepad. The output will operate for 200 ms if you program the polarity as one (1). However, you can program the time base and multiplier to increase the duration that the output will operate.
- | | |
|------------------------|------------------------------------|
| 35 Mimic Zone 1 | 39 Mimic Zone 5 |
| 36 Mimic Zone 2 | 3¹⁰ Mimic Zone 6 |
| 37 Mimic Zone 3 | 3¹¹ Mimic Zone 7 |
| 38 Mimic Zone 4 | 3¹² Mimic Zone 8 |
- These output types will mimic the zone inputs. The output will operate when the zone is unsealed and will reset when the zone has resealed. They will operate regardless of the zone type chosen (i.e.. A zone "Not Used" can still operate a mimic output). This feature operates when the system is armed or disarmed.
- 45 Global Chime**
 This output will operate when any zones programmed as "Chime" have triggered. The output will reset when the zone has resealed. Refer to Zone Type on page 169 for more information.
- 46 Zone Not Sealed**
 This output will operate whenever a burglary zone is unsealed. Chime zones will not operate this output event type.

4 7 Zone Not Sealed After Exit Time
This output will operate at the end of exit time if a burglary zone is unsealed. The output will reset when all zones are sealed or the system has been disarmed. Chime zones will not operate this output event type.

4 9 AC Mains 60 Hz Or 50 Hz
This output will activate when the AC mains supply frequency is at 60 Hz. The output will reset once the AC mains supply has returned to 50 Hz.

The following output event types are only applicable to the Solution Ultima 880 control panel when partitioned.

4 10 Area 1 Has Zone Unsealed **4 11 Area 2 Has Zone Unsealed**
These two outputs will operate when a zone in their corresponding area has registered as unsealed when the area is either armed in AWAY Mode or STAY Mode, or the area is disarmed.

Example

Zone 1 is allocated to Area 1. If Zone 1 becomes unsealed, Output Event Type 4,10 will operate. The output will reset once the zone has resealed.

5 2 Area 1 In Alarm **5 3 Area 2 In Alarm**
These two outputs will operate when a zone in their corresponding area has registered an alarm. These outputs will reset once a valid user code has been entered.

Example

Zone 1 has been allocated to Area 1. If Zone 1 has registered an alarm, Output Event Type 5,2 will operate. The output will reset once a valid user code allocated to operate Area 1 has been entered.

5 6 Area 1 Is Armed **5 7 Area 2 Is Armed**
These two outputs will operate when their corresponding area has been armed in AWAY Mode or STAY Mode 1. The output will reset once the corresponding area is disarmed.

Example

If area 1 has been armed in AWAY Mode or STAY Mode 1, Output Event Type 5,6 will operate. The output will reset once Area 1 is disarmed.

5 10 Area 1 Is Disarmed **5 11 Area 2 Is Disarmed**
These two outputs will operate when their corresponding area has been disarmed. The output will reset once the corresponding area is armed.

Example

If Area 1 has been disarmed, Output Event Type 5,10 will operate. The output will reset once Area 1 is disarmed.

5 14 Any Areas Armed
This output will operate when either Area 1 or Area 2 has become armed in AWAY Mode or STAY Mode 1. The output will reset when both areas are disarmed.

5 15 Any Areas Disarmed
This output will operate when either Area 1 or Area 2 has become disarmed. The output will reset when both areas are armed in either AWAY Mode or STAY Mode 1.

60 Area 1 Codepad Data Terminal

This output type is used to connect the data terminal of the Area 1 codepad when you are using the Master Partitioned codepad as the main codepad. Set DIP switch 1 in the ON position for the Area 1 codepad to operate correctly. Refer to Figure 12: DIP Switch Location On Back Of Codepad PCB below for the location of the DIP switches on the pack of the codepad.

If you are not using a Master Partitioned as the main codepad, connect the data cable from the Area 1 codepad to the DATA terminal on the control panel and enable Option 2 in "LOCATION 444" on page 241.

Refer to Codepad Connections For Partitioning on page 247 for further information on connecting codepads when the system has been partitioned.

61 Area 2 Codepad Data Terminal

This output type is used to connect the data terminal of the Area 2 codepad. Set DIP Switch 2 to the ON position for the Area 2 codepad to operate correctly. Refer to Figure 12: DIP Switch Location On Back Of Codepad PCB below for the location of the DIP switches on the back of the codepad.

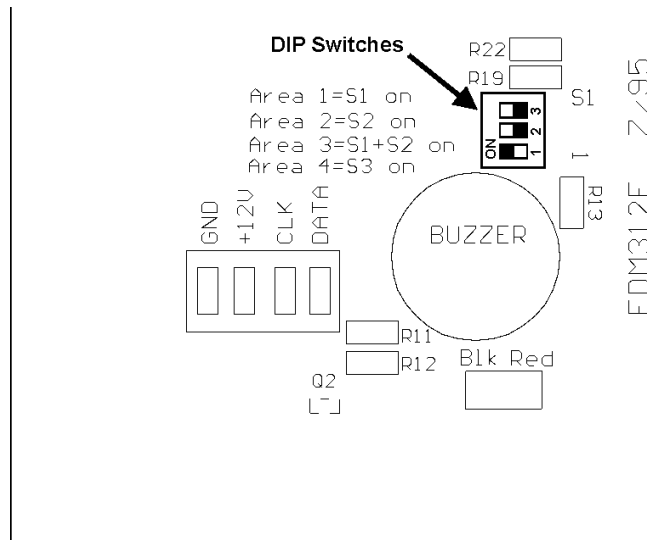

Figure 12: DIP Switch Location On Back Of Codepad PCB

Output Polarity

There are fifteen different polarities to choose from. Each polarity is designated by a number. This number needs to be programmed into the appropriate location of the output being used to indicate how the output should operate.

<i>Option</i>	<i>Polarity</i>	<i>Option</i>	<i>Polarity</i>
0	Output Not Used		
1	Normally Open, Going Low	8	Normally Low, Going Open
2	Normally Open, Pulsing Low	9	Normally Low, Pulsing Open
3	Normally Open, One Shot Low	10	Normally Low, One Shot Open
4	Normally Open, One Shot Low (Retrigger)	11	Normally Low, One Shot Open (Retrigger)
5	Normally Open, One Shot Low (Can Reset)	12	Normally Low, One Shot Open (Can Reset)
6	Normally Open, One Show Low (Alarm)	13	Normally Low, One Shot Open (Alarm)
7	Normally Open, Latching Low	14	Normally Low, Latching Open

Table 117: Event Type Polarities

Output Not Used

- 0 If an output is not required for use, the polarity should be programmed as zero.

Normally Open, Going Low

- 1 This polarity is normally open circuit and will switch to zero volts when the event occurs. The output will switch back to open circuit when the event has restored. Time parameters are not applicable to this polarity.

Normally Open, Pulsing Low

- 2 This polarity is normally open circuit and will switch to pulsing zero volts when the event occurs. The output will switch back to open circuit when the event has restored. Time parameters vary the "On" time of the pulse.

Normally Open, One Shot Low

- 3 This one shot polarity is normally open circuit and will switch to zero volts when the event occurs. The output will switch back to open circuit when the time parameter setting has expired. This one shot time setting will always run its full duration and cannot be manually reset.

Normally Open, One Shot Low With Retrigger

- 4 This one shot polarity is normally open circuit and will switch to zero volts when the event occurs. Every time the event occurs, it will restart the one shot timer. The output will switch back to open circuit once the one shot time has expired.

This polarity is ideally suited for lighting control. A PIR can be used to trigger an output for turning on lights. While ever there is movement, the PIR will keep re-triggering the output and lengthen the time the lights will remain switched on.

Normally Open, One Shot Low With Reset

- 5 This one shot polarity is normally open circuit and will switch to zero volts when the event occurs. The output will switch back to open circuit when the one shot time has expired or when the event has returned to normal. This means the operation of the output can be shortened regardless of the time parameter programmed.

Normally Open, One Shot Low With Alarm

- 6 This one shot polarity is normally open circuit and will switch to zero volts when the event occurs. The output will switch back to open circuit once the one shot time has expired, when the event has returned to normal or when the system has been disarmed.

This polarity is ideally suited for the operation of strobe lights as they can be programmed (Up to 99 hours) to reset and prevent them from burning out or becoming annoying to others from prolonged operation.

Normally Open, Latching Low

- 7 This polarity is normally open circuit and will switch to zero volts when the event occurs. The output will switch back to open circuit once the **7** button on the remote codepad is held down until two beeps are heard. Time parameters are not applicable to this polarity.

Normally Low, Going Open

- 8 This polarity is normally zero volts and will switch to open circuit when the event occurs. The output will switch back to zero volts when the event has restored. Time parameters are not applicable to this polarity.

Normally Low, Pulsing Open

- 9 This polarity is normally zero volts and will switch to pulsing open circuit when the event occurs. The output will switch back to zero volts when the event has restored. Time parameters vary the "Off" time of the pulse.

Normally Low, One Shot Open

- 10 This one shot polarity is normally zero volts and will switch to open circuit when the event occurs. The output will switch back to zero volts when the time parameter has expired. This one shot time setting will always run its full duration and cannot be manually reset.

Normally Low, One Shot Open With Retrigger

- 11 This one shot polarity is normally zero volts and will switch to open circuit when the event occurs. Every time the event occurs, it will restart the one shot timer. The output will switch back to zero volts once the one shot time has expired.

Normally Low, One Shot Open With Reset

- 12 This one shot polarity is normally zero volts and will switch to open circuit when the event occurs. The output will switch back to zero volts when the one shot time has expired or when the event has returned to normal. This means the one shot timer can be shortened regardless of the time setting.

Normally Low, One Shot Open With Alarm

- 13 This one shot polarity is normally zero volts and will switch to open circuit when the event occurs. The output will switch back to zero volts when the one shot time has expired, when the event has returned to normal or when the system has been disarmed. This means that the one shot timer can be shortened regardless of the time setting.

Normally Low, Latching Open

- 14 This polarity is normally zero volts and will switch to open circuit when the event occurs. The output will switch back to zero volts once the **7** button on the remote codepad has been held down until two beeps are heard. Time parameters are not applicable to this polarity.

Timing Of Outputs

The timing of outputs is calculated by the time base and a multiplier. These two values play different roles depending on the polarity selected. When programming outputs to pulse, both the "On" and "Off" times can be set. One shot polarities can be programmed to operate between 200 ms up to 99 hours in duration.

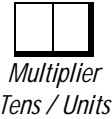

The maximum value that can be programmed in the two multiplier locations is **99**.

Option	Time Base
1	200 ms
2	1 Second
3	1 Minute (60 Seconds)
4	1 Hour (60 Minutes)

Table 118: Time Base Settings

The time base settings can be set to only one of the values listed in "Table 118: Time Base Settings". The multiplier value is a two digit decimal number from 00-99. For greater accuracy, use 60 seconds for 1 minute intervals and use 60 minutes for one hour intervals.

Pulsing Polarities

When calculating pulsing polarities both the "On" and "Off" times need to be programmed. The duration or "On" time of an output is determined by selecting only one of the time base options from "Table 118: Time Base Settings". This means there are only four "On" times to choose from.

The "Off" time is calculated as a multiple of the "On" time by choosing a decimal number between 00 and 99. If an output is required to operate for 200 ms every five seconds, program the time settings as follows;



ON Time	OFF Time	Increments	Tolerance
200 ms	200 ms - 19.8 ms	200 ms	+/- 200 ms
1 Sec	1 Sec - 99 Sec's	1 Sec	+/- 1 Sec
1 Min	1 Min - 99 Min's	1 Min	+/- 1 Min
1 Hour	1 Hour - 99 Hours	1 Hour	+/- 1 Hour

Table 119: Pulsing Time Settings

One Shot Polarities

The duration or "On" time of an output is determined by the product of the time base and the multiplier.

If an output is required to operate for five seconds, program the time settings as follows;



The "On" time is calculated by multiplying the time base setting (1 second) by the multiplier value (05).

(i.e.. 1 x 05 = 5 seconds)

<i>On Time</i>	<i>Increments</i>	<i>Tolerance</i>
200 ms - 19.8 Sec's	200 ms	+/- 200 ms
1 Sec - 99 Sec's	1 Sec	+/- 1 Sec
1 Min - 99 Min's	1 Min	+/- 1 Min
1 Hour - 99 Hours	1 Hour	+/- 1 Hour

Table 120: One Shot Time Settings

System Event Timers

This section includes the following:

- *Entry Timer 1*
- *Entry Timer 2*
- *Exit Time*
- *Entry Guard Timer For STAY Mode*
- *Delay Alarm Reporting Time*
- *Sensor Watch Time*
- *Codepad Lockout Time*
- *Siren Run Time*
- *Siren Sound Rate*
- *Auto Arming Pre-Alert Timer*
- *Auto Arming Time*
- *Auto Disarming Time*
- *Kiss-Off Wait Time*
- *System Time*
- *System Date*

System Event Timers

This section covers the features that involve timing. Features such as entry and exit times, sensor watch time, siren run time and system date and time along with a host of other timers are discussed extensively in this section.

Programming Entry/Exit Timers

There are two locations to be programmed for Entry Timer 1, Entry Timer 2, Exit Time For AWAY Mode and Entry Guard Time For STAY Mode.

The first location of the timer is for programming increments of 1 second. The second location of the timer is for programming increments of 16 seconds. By adding these two locations together will give the total time required.

Example

If you require the entry time to expire after 18 seconds, you would need to program “LOCATION 410” as 2 (i.e.. 2 x 1 second = 2 seconds) and “LOCATION 411” as 1 (i.e.. 1 x 16 seconds = 16 seconds). This would give you the total time of 18 seconds (i.e.. 2 + 16 seconds = 18 seconds).

Entry Timer 1

LOCATION 410 - 411 (Defaulted To 20 Seconds)

41

<i>Location</i>	<i>Description</i>
410	Increments Of 1 Second (0 – 15 Sec’s)
411	Increments Of 16 Seconds (0 – 240 Sec’s)

Table 121: Entry Timer 1 Locations

Entry time can be programmed between 0 and 255 seconds in increments of one second. Entry Timer 1 is the delay time used by the zone type – Delay-1. Refer to Zone Types on page 171 for more information.

Entry Timer 2

LOCATION 412 - 413 (Defaulted To 40 Seconds)

82

<i>Location</i>	<i>Description</i>
412	Increments Of 1 Second (0 - 15 Sec’s)
413	Increments Of 16 Seconds (0 –240 Sec’s)

Table 122: Entry Timer 2 Locations

Entry time can be programmed between 0 and 255 seconds in increments of one second. Entry Timer 2 is the delay time used by the zone type – Delay-2. Refer to Zone Types on page 171 for more information.

Exit Time**LOCATION 414 – 415** (Defaulted To 60 Seconds)

12 3

<i>Location</i>	<i>Description</i>
414	Increments Of 1 Second (0 - 15 Sec's)
415	Increments Of 16 Seconds (0 -240 Sec's)

Table 123: Exit Time Locations

Exit time can be programmed between 0 and 255 seconds in increments of one second. When arming the system in AWAY Mode, the remote codepad will beep during exit time until the remaining 10 seconds where the codepad will give you one continuous beep to inform you that the end of exit time is approaching.

The remote codepad will always give one short beep at the end of exit time when arming in STAY Mode 1 or STAY Mode 2.

Entry Guard Timer For STAY Mode**LOCATION 416 - 417** (Defaulted To 00 Seconds)

OO

<i>Location</i>	<i>Description</i>
416	Increments Of 1 Second (0 - 15 Sec's)
417	Increments Of 16 Seconds (0 -240 Sec's)

Table 124: Entry Guard Timer For STAY Mode Locations

"Entry Guard Timer For STAY Mode" is the delay time used for ALL zones except 24 hour burglary and 24 hour fire zones when the system is armed in STAY Mode 1 or STAY Mode 2. Each zone including delay zones will have the entry delay as programmed in "LOCATION 416 - 417" (i.e.. The entry guard timer will override the delay time programmed for a delay zone). If the entry guard timer has been programmed as "0" each zone will act as per its programmed zone type.

Refer to Zone Options 2 on page 179 to program zones to be automatically isolated in STAY Mode 1. Refer to Setting STAY Mode 2 Zones on page 86 to program zones to be automatically isolated in STAY Mode 2 via the Master Code.

Delay Alarm Reporting Time**LOCATION 418 – 419** (Defaulted To 00 Seconds)

OO

<i>Location</i>	<i>Description</i>
418	Increments Of 1 Second (0 - 15 Sec's)
419	Increments Of 16 Seconds (0 -240 Sec's)

Table 125: Delay Alarm Reporting Time Locations

These locations programs the time in seconds that a delayed report waits dormant in the dial buffer before reporting to the receiving party. If a user code holder resets the alarm condition within this time frame, the control panel will clear the dialler buffer and prevent the alarm from reporting to the receiving party. Refer to Zone Options 1 on page 175 to program zones for delay alarm reporting.

LOCATION 420 - 421



<i>Location</i>	<i>Description</i>
420	Increments Of Days (Tens Digit)
421	Increments Of Days (Units Digit)

Table 126: Sensor Watch Time Locations

The time set in these two locations determine how many days (0-99) a zone may remain sealed before registering as a fault. This feature is only active when the system is in the disarmed state. If a zone programmed for sensor watch has not become unsealed and reset during this time, the FAULT indicator will illuminate. Refer to Fault Descriptions on page 53 for further information on sensor watch faults. Refer to Zone Options 1 on page 175 for programming zones for sensor watch.

The sensor watch time counter is only active whilst the control panel is disarmed. Therefore, if the system is only disarmed for 8 hours a day and the sensor watch time is programmed for 1 day, a zone that is programmed for sensor watch will register a sensor watch fault if not triggered during the disarmed state within 3 days.

This feature would be useful in a situation where someone has moved objects in the view of the detector, blocking out the detector from picking up movement. Refer to LOCATION 333 - 334 on page 186 if you wish to disable sensor watch reports.

LOCATION 422



<i>Location</i>	<i>Description</i>
422	Increments Of 10 Seconds (0 - 150 Seconds)

Table 127: Codepad Lockout Time Locations

All codepads will be locked out for the specified time programmed if an invalid code has been entered more times than allowed by the code retry attempts programmed in "LOCATION 368 - 370" on page 195. If the Codepad Lockout Time is programmed as zero, no codepad lockout will occur.

Siren Run Time**LOCATION 423** (Defaulted To 5 Minutes)**5**

<i>Location</i>	<i>Description</i>
423	Increments Of 1 Minute (0 – 15)

Table 128: Siren Run Time Location

The siren run time determines how long the horn speaker will activate during an alarm condition. The siren run time can be programmed between 0 - 15 minutes (+/- 1 minute).

Siren Sound Rate**LOCATION 424****7**

<i>Location</i>	<i>Description</i>
424	Siren Sound Rate (0 = SLOWEST 15 = FASTEST)

Table 129: Siren Sound Rate Location

The siren sound rate varies the frequency of the siren tone. Programming the siren sound rate as a zero is the slowest and fifteen is the fastest. The siren sound rate does not change the frequency rate for the fire alarm tone.

LOCATION 425

1

<i>Location</i>	<i>Description</i>
425	Increments Of 5 Minutes (0 – 75 Minutes)

Table 130: Auto Arming Pre-Alert Timer Location

This location sets the time period that will warn you before the control panel will automatically arm in AWAY Mode. The codepad will beep once every second until the pre-alert timer has expired, after this time, the system will automatically arm itself in AWAY Mode. If you require the system to automatically arm in STAY Mode 1, enable Option 4 in “LOCATION 440” on page 231.

Once the control panel has automatically armed in AWAY Mode or STAY Mode 1, exit time will commence. If a valid user code is entered during the pre-alert time, the auto arming time as programmed in “LOCATION 426 - 429” will extend by one hour.

If you require a programmable output to operate during the auto arming pre-alert time, refer to Output Event Type – Auto Arm Pre-Arming Alert Time on page 202.

LOCATION 426 - 429

○○○○

<i>Location</i>	<i>Description</i>
426	Actual Hour Of The Day (Tens Digit)
427	Actual Hour Of The Day (Units Digit)
428	Actual Minute Of The Day (Tens Digit)
429	Actual Minute Of The Day (Units Digit)

Table 131: Auto Arming Time Locations

These locations are used to program the actual time of the day that the system will automatically arm itself in AWAY Mode. This time must be set in 24 hour format (i.e.. 10:30 PM would be programmed as 2230). Refer to Option 4 in “LOCATION 440” on page 231 if you require the system to arm in STAY Mode 1.

If forced arming has been disabled for any zone, the feature of automatic arming will operate regardless of any zones being unsealed. Refer to Zone Options 2 on page 179 for more information on programming zones for forced arming.

User code 16 will be report when the feature of automatic arming is used.

On *Solution Ultima 880* control panels that have been partitioned into two separate areas, both areas will automatically arm in AWAY Mode at the same time every day.

Auto Disarming Time**LOCATION 430 - 433**

○○○○

<i>Location</i>	<i>Description</i>
430	Actual Hour Of The Day (Tens Digit)
431	Actual Hour Of The Day (Units Digit)
432	Actual Minute Of The Day (Tens Digit)
433	Actual Minute Of The Day (Units Digit)

Table 132: Auto Disarming Time Locations

These locations are used to program the actual time of the day that the system will automatically disarm itself from AWAY Mode, STAY Mode 1 or STAY Mode 2. This time must be set in 24 hour format (i.e.. 10:30 PM would be programmed as 2230).

User code 16 will report when the feature of automatic disarming is used.

On *Solution Ultima 880* control panels that have been partitioned into two separate areas, both areas will automatically disarm at the same time every day.

**V1.00 – V1.07**

The system failed to automatically disarm if the system was not programmed to automatically arm. To solve the problem, we suggest that you program the automatic arming time as 25:00 hours if you only require the control panel to disarm.

Kiss-Off Wait Time**LOCATION 434**

3

<i>Location</i>	<i>Description</i>
434	Increments Of 500 ms (500 ms – 8 Sec's)

Table 133: Kiss-Off Wait Time Location

This location sets the time that the control panel will wait for acknowledgment before resending the report. This applies only to Contact ID Format and 4 + 2 Express Formats.

Speaker Beep Volume**LOCATION 435**

13

<i>Location</i>	<i>Description</i>
435	0 = No Beeps / 15 = Loudest Beeps

Table 134: Speaker Volume Location

This location allows you to adjust the volume of speaker beeps for remote radio operation.

LOCATION 901 – 904



<i>Location</i>	<i>Description</i>
901	Current Hour In 24 Hour Time (Tens Digit)
902	Current Hour In 24 Hour Time (Units Digit)
903	Current Minute (Tens Digit)
904	Current Minute (Units Digit)

Table 135: System Time Locations

The *Solution Ultima 844/862/880* control panel has a real time 24 hour clock that needs to be set during installation. This time must be set in 24 hour format HHMM (i.e.. 10:30 PM would be programmed as 2230). Every time the system has been powered down, the system time will need to be reset.

LOCATION 905 – 910

010101

<i>Location</i>	<i>Description</i>
905	Day Of The Month (Tens Digit)
906	Day Of The Month (Units Digit)
907	Month Of The Year (Tens Digit)
908	Month Of The Year (Units Digit)
909	Year (Tens Digit)
910	Year (Units Digit)

Table 136: System Date Locations

The *Solution Ultima 844/862/880* control panel has a real time 12 month calendar that needs to be set during installation. This time must be set using the format DDMMYY (i.e.. If the date that is required to be set is the 1 July 1997, you would then program 010797). Every time the system has been powered down, the system date will need to be reset.

Setting The Date and Time

The Master Code holder is allowed to set the date and time as follows:

How To Set The New Date and Time

1. Enter your **MASTER CODE** followed by **6** and the **AWAY** button.
Three beeps will be heard and the STAY and AWAY indicators will begin to flash.
2. Enter the day, month, year, hour and minute using the (DD, MM, YY, HH, MM) format (i.e.. DD = Day of the month, MM = Month of the year, YY = Current year, HH = Hour of the day, MM = Minute of the day).
 Please note that when programming the hour of the day, you will need to use 24:00 hour format.
3. Press the **AWAY** button when finished.
Two beeps will be heard and the STAY and AWAY indicators will extinguish. If a long beep is heard, an error was made when entering the date and time.

Example

If the date and time needs to be set for the 1st January 1997 at 10:30 PM, program the date and time as follows;

$$2580 + 6 + \text{AWAY}$$

$$01 + 01 + 97 + 22 + 30$$

$$+ \text{AWAY}$$

System and Consumer Options

This section includes the following:

- *System Options 1*
- *System Options 2*
- *System Options 3*
- *System Options 4*
- *Consumer Options 1*
- *Consumer Options 2*
- *Consumer Options 3*
- *Radio Input Options*

Programming Option Bits

When programming these locations, you will notice that there are four options per location. You may select one, two, three or all four of these options, however, only one number needs to be programmed. This number is calculated by adding the option bit numbers together. Program a seven (7) if you require options 1, 2 and 4 simultaneously (i.e.. $1 + 2 + 4 = 7$).

Example

If at "LOCATION 436" you want options 1, 2 and 4, add the numbers together and the total is the number to be programmed. In this example, the number to be programmed is 7 (i.e.. $1 + 2 + 4 = 7$).

<i>Option</i>	<i>Description</i>
1	EDM Smart Lockout Allowed
2	Horn Speaker Monitor
4	Strobe Indications For Radio Arm/Disarm
8	Assign Button 4 On Transmitter To Operate STAY Mode 1

Table 137: Example - Programming Option Bits

LOCATION 436

1

<i>Option</i>	<i>Description</i>
1	EDM Smart Lockout Allowed
2	Horn Speaker Monitor
4	Strobe Indications For Radio Arm/Disarm
8	Assign Button 4 On Transmitter To Operate STAY Mode 1

Table 138: System Options 1

EDM Smart Lockout Allowed

- 1 This feature allows the control panel to remove any zones that are programmed for lockout dialler from the lockout list while the sirens are running. This feature allows a monitoring station to receive zone alarm reports from previously locked out zones during siren run time. Refer to Zone Options 1 on page 175 for information on programming zones for lockout dialler and lockout siren.

Refer to Swinger Shutdown Count For Dialler on page 182 to program the number of times the zone can report before being locked out.

Horn Speaker Monitor

- 2 If this option has been selected, the control panel will detect when the horn speaker has been disconnected from the speaker terminals. The FAULT indicator will illuminate when the horn speaker has been disconnected and will extinguish when the horn speaker has been reconnected.

If an output is required to operate when the horn speaker has been disconnected, refer to Output Event Type – Horn Speaker Monitor Fail on page 204 for more information.

Strobe Indications For Radio Arm/Disarm

- 4 This option will allow the strobe to indicate when the system is armed and disarmed when remotely operating the system via the 304 MHz RF Receiver (RF3212).

<i>No Of Seconds</i>	<i>System Status</i>
3 Seconds	System Disarmed
6 Seconds	System Armed In AWAY Mode
6 Seconds	System Armed In STAY Mode 1

Table 139: Strobe Indications For Remote Operations

Assign Button 4 On Transmitter To Arm STAY Mode 1

- 8 This option will allow button 4 on the 4 Channel Hand Held Transmitter (RF3334) to arm the system in STAY Mode 1.

LOCATION 437



<i>Option</i>	<i>Description</i>
1	Codepad Panic To Be Silent
2	Codepad Fire To Be Silent
4	Codepad Medical To Be Silent
8	Access Denied To Be Silent

Table 140: System Options 2

Codepad Panic To Be Silent

- 1 If this option has been selected, a codepad panic alarm or radio remote panic alarm will not operate the horn speaker, the bell or the strobe outputs. If this option is not selected, all three outputs will operate after a codepad panic alarm has been activated when the **1** and **3** buttons or the **STAY** and **AWAY** buttons on the remote codepad are pressed simultaneously. Selecting this option does not effect the operation of the communication dialler.

If you wish to disable the reporting of the codepad panic alarm, program "LOCATION 349 - 350" on page 190 as zero.

Codepad Fire To Be Silent

- 2 If this option has been selected, a codepad fire alarm will not operate the horn speaker, the bell or the strobe outputs. If this option is not selected, all three outputs will operate after a codepad fire alarm has been activated when the **4** and **6** buttons on the remote codepad are pressed simultaneously. Selecting this option does not effect the operation of the communication dialler.

If you wish to disable the reporting of the codepad fire alarm, program "LOCATION 351 - 352" on page 191 as zero.

Codepad Medical To Be Silent

- 4 If this option has been selected, a codepad medical alarm will not operate the horn speaker, the bell or the strobe outputs. If this option is not selected, all three outputs will operate after a codepad fire alarm has been activated when the **7** and **9** buttons on the remote codepad are pressed simultaneously. Selecting this option does not effect the operation of the communication dialler.

If you wish to disable the reporting of the codepad medical alarm, program "LOCATION 353 - 354" on page 191 as zero.

Access Denied To Be Silent

- 8 If this option has been selected, a codepad tamper alarm will not operate the horn speaker, bell or the strobe outputs. If this option is not selected, all three outputs will operate after a codepad tamper alarm has occurred.

Refer to "LOCATION 368" on page 195 to set the number of invalid code retries before an alarm condition occurs. Selecting this option does not effect the operation of the communication dialler. If you wish to disable the reporting of access denied reports program "LOCATION 369 - 370" as zero.

LOCATION 438

8

<i>Option</i>	<i>Description</i>
1	AC Fail In 1 Hour (Disabled = After 2 Minutes)
2	Ignore AC Fail
4	Pulse Count Handover Allowed
8	Handover Delay To Be Sequential

Table 141: System Options 3

AC Fail In 1 Hour (Disabled = After 2 Minutes)

1 If this option has been selected, the MAINS indicator will begin to flash as soon as the AC mains supply becomes disconnected. An "AC Loss" signal (Contact ID Event Code 301) will be sent to the base station receiver after the AC mains supply has been disconnected continuously for more than 60 minutes.

If this option has not been selected, the MAINS indicator will begin to flash and an "AC Loss" signal (Contact ID Event Code 301) will be sent to the base station receiver after the AC mains power has been disconnected continuously for 2 minutes.

The MAINS indicator will cease to flash once the AC mains supply has been restored for more than two minutes. An "AC Loss Restore" report will be sent to the base station receiver after the AC mains supply has been restored continuously for more than 2 minutes irrespective of this option being set.

Ignore AC Fail

2 If this option has been selected, the MAINS indicator will not flash, nor will the codepad beep once every minute when the AC mains has been disconnected from the control panel. If you require a programmable output to operate when the AC mains has failed, refer to Output Event Type – AC Fail on page 204.

If this options has been selected, an "AC Loss" report (Contact ID Event Code 301) will still report to the base station receiver unless disabled in "LOCATION 360 - 361" on page 193.

Zone Pulse Count Handover Allowed

4 If this option has been selected, any zone pulse count readings will handover and accumulate to any zone that is triggered during the same arming cycle. Zone pulse count handover will only operate with zone pulse count options 8-15. Refer to Zone Pulse Count on page 173 and Zone Pulse Count Time on page 174 for more information.



24-hour zones do not receive any handover pulses from other zones. 24-hour zones can handover pulses to other zones.

Handover Delay To Be Sequential

8 If this option has been selected, handover delay will be sequential (i.e.. In numerical order from lowest to highest). If the sequence is broken before the entry time expires, an alarm will occur. If this option has not been selected, handover delay will follow the entry path provided that a delay zone has been triggered first. Refer to "Handover Zone" on page 171 for more information.

LOCATION 439



<i>Option</i>	<i>Description</i>
1	Panel To Power Up Disarmed (If Power Reset)
2	Arm/Disarm Tracking On Power Up
4	Internal Crystal To Keep Time
8	Keyswitch Interface, Night Arm Station Or RE005 Installed

Table 142: System Options 4

Panel To Power Up Disarmed (If Power Reset)

1 If this option has been selected, the control panel will power up in the disarmed state once the battery and AC mains have been reconnected after the system has been powered down.

If this option is not selected, the system will always power up armed in AWAY Mode.

Arm/Disarm Tracking On Power Up

2 If enabled, the control panel will keep its current armed status in non-volatile memory. If for any reason the control panel is restarted due to a power failure, the control panel will return to the armed or disarmed status that the control panel was in before the power failed.

Example

If the system was disarmed prior to the system being powered down, when the system is powered back up, the system will return to the disarmed state.

Internal Crystal To Keep Time

4 If this option has been selected, it will force the control panel not to use the mains frequency as a time base to keep time. The control panel will use the internal crystal (XTAL) to keep track of time. This option is useful in countries that do not have a constant mains frequency.

Keyswitch Interface, Night Arm Station Or RE005 Installed

8 This option must be selected when using the Radio Key/Keyswitch Interface (CC813), 2 Channel Radio Interface (RE005), or the Night Arm Station (CP105). This option allows the control panel to be operated using any of these three accessories. When using these optional accessories, they will report as User Code 16.



Using a Solution Ultima 880 control panel that has been partitioned, the Night Arm Station will not operate the system.

LOCATION 440



<i>Option</i>	<i>Description</i>
1	Test Reports Only When Armed
2	Test Report After Siren Reset
4	Auto Arm In STAY Mode 1
8	STAY Indicator To Display Day Alarm Status

Table 143: Consumer Options 1

Test Reports Only When Armed

- 1** If this option has been selected, test reports (Contact ID Event Code 602) will only be sent when the system has been armed in AWAY Mode, STAY Mode 1 or STAY Mode 2. It is no longer necessary to send a test report as well as an opening and closing report every day.

During the working week, most commercial premises would be open and therefore a test report is not necessary, as open and close reports would be sent at the time programmed. If you wish to manually send a test report, hold down the  button until two beeps are heard.

Refer to Test Reporting Time on page 197 to set the test report time required. To set the first test report, refer to the Installer Code Function – Set The Number Of Days Until The First Test Report on page 65.

Test Report After Siren Reset

- 2** Selecting this option will force the control panel to send a test report after the siren has reset. This can be used to indicate to the monitoring station that the control panel itself has not been tampered with during the alarm period.

Auto Arm In STAY Mode 1

- 4** If automatic arming in STAY Mode 1 is preferred to automatic arming in AWAY Mode, this option will need to be selected.

Refer to “LOCATION 426 - 429” on page 220 to program the time that the control panel will automatically arm itself and “LOCATION 425” on page 220 to set the auto arming pre-alert time.



When using this option with a partitioned Solution Ultima 880 control panel, both areas will automatically arm in STAY Mode 1.

STAY Indicator To Display Day Alarm Status

- 8** If this option has been selected, the STAY indicator will be used to display when day alarm has been enabled. The STAY indicator will flash once every 3 seconds while day alarm is active.

Refer to “LOCATION 265” on page 164 for programming zones to operate for day alarm operation.

Day alarm can be turned on and off by holding down the **4** button for 2 seconds. Three beeps indicate day alarm is turned on and two beeps indicate day alarm is turned off. Refer to Day Alarm Operation on page 165 for more information.

LOCATION 441

2

<i>Option</i>	<i>Description</i>
1	Codepad Display Extinguish After 60 Seconds
2	Single Button Arming Allowed (AWAY Mode, STAY Mode 1 & 2)
4	Single Button Disarming Allowed (STAY Mode 1 & 2)
8	Alarm Memory Reset On Disarm

Table 144: Consumer Options 2

Codepad Display Extinguish After 60 Seconds

- 1 If this option has been selected, all indicators on the remote codepad display will extinguish if a button is not pressed for 60 seconds. The indicators will illuminate when there is an alarm (except a silent alarm), when a button is pressed on the codepad, when the AC mains fail beeps, or if the entry timer has been activated.

Single Button Arming Allowed (AWAY Mode, STAY Mode 1 & 2)

- 2 If this option has been selected, the hold down functions for arming in AWAY Mode, STAY Mode 1 and STAY Mode 2 will be functional. Refer to Hold Down Functions on page 93 for more information.

Single Button Disarming Allowed (STAY Mode 1 & 2)

- 4 This option will only operate when Option 2 in this location has also been selected. This option will allow hold down functions for disarming from STAY Mode 1 and STAY Mode 2. Refer to Hold Down Functions on page 93 for more information.

Alarm Memory Reset On Disarm

- 8 This option allows the memory of alarm events to be cleared from the remote codepad when the system has been disarmed. If this option has not been selected, the system will need to be armed and disarmed again to clear alarm memory from the remote codepad.

LOCATION 442

5

<i>Option</i>	<i>Description</i>
1	Codepad Fault Alarm Beeps Allowed
2	Use Digit 3 For Codepad Duress Instead Of Digit 9
4	Alarms Activate Siren and Strobe Outputs In STAY Mode 1 & 2)
8	Zone Tamper Alarms To Be Silent

Table 145: Consumer Options 3

Codepad Fault Alarm Beeps Allowed

- 1 If this option has been enabled, the codepad will flash the FAULT indicator and beep once every minute until acknowledged when a system fault has occurred. To acknowledge a new fault and stop the codepad from beeping once every minute, simply press the  button.

If this option has not been enabled, the codepad will only flash the FAULT indicator when a new fault has occurred, but will not cause the codepad to beep once every minute until the fault has been acknowledge or rectified.

Use Digit 3 For Codepad Duress Instead Of Digit 9

- 2 This option if selected, will allow the customer to use the digit **3** after entering their code to disarm the system to activate a duress alarm.

Alarms Activate Siren & Strobe In STAY Mode 1 & 2

- 4 This option will need to be selected if audible alarms are required when the system has been armed in STAY Mode 1 or STAY Mode 2.

Zone Tamper Alarms To Be Silent

- 8 This option allows tamper alarms when using Option 14 in LOCATION 266 on page 166 or the tamper alarms on RF wireless devices to be silent when triggered into alarm condition.

LOCATION 443



<i>Option</i>	<i>Description</i>
1	DS304 MHz Receiver (RF3212)
2	Latching Keyswitch Input
4	Momentary Keyswitch Input
8	Reserved

Table 146: Radio Input Options

DS304 MHz Receiver (RF3212)

- 1** This option needs to be selected when using the optional 304 MHz RF Receiver (RF3212) for remote operations using radio remote hand held Transmitters.

Latching Keyswitch Input

- 2** This option allows you to connect a latching keyswitch to the JP3 terminals D and GND to remotely arm and disarm the system in AWAY Mode.

Momentary Keyswitch Input

- 4** This option allows you to connect a momentary keyswitch to the JP3 terminals D and GND to remotely arm and disarm the system in AWAY Mode.

Partitioning

This section includes the following:

- *CP5 Master Partitioned LED Codepad*
- *Operating Codepads In Partitioning*
- *Programming*
- *Partitioning Options 1*
- *Partitioning Options 2*
- *Zone Allocations*
- *User Code Allocations*
- *Setting Up and Programming Codepads For Partitioning*
- *Codepad Connections For Partitioning*

The *Solution Ultima 880* control panel includes a feature called partitioning which can effectively transform your single control panel and split the system into two separate areas. Normally arming and disarming the system would turn the entire system on or off. However, when the *Solution Ultima 880* control panel has been partitioned, you may arm or disarm an individual area without affecting the other area.

Partitioning is extremely useful when you wish to secure sheds, dual occupancy dwellings, granny flats, shops and offices.

When partitioning, only the CP5 Area Addressable (CP500A) codepad and the CP5 Master Partitioned (CP500P) codepad can be used.

CP5 Master Partitioned LED Codepad

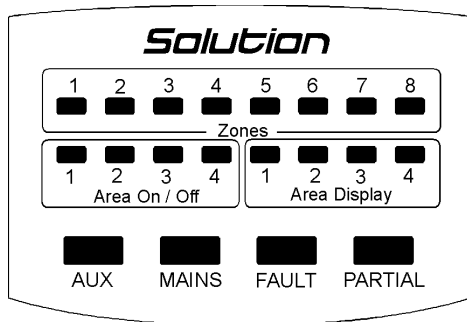

This codepad is only used on the *Solution Ultima 880* control panel when partitioned. The Master Partitioned LED codepad will allow the user to operate both areas individually from the same codepad, without the need to operate individual areas from separate codepads.

The codepad is the communications interface between you and your alarm system. The codepad allows you to issue commands and offers both visual and audible indications that guide you through the general operation.

The codepad incorporates numerous indicators. There are ZONE indicators that are used to show the condition of each zone and four others for general status. The following is a list of situations and the relevant indications that will be seen.

Figure 13: CP5 Master Partitioned LED Codepad (CP500P)

The indicators on a CP5 Master Partitioned LED codepad are configured in to four groups. Following is a description of what the indicators mean.

Zone Indicators

1

The ZONE indicators are used to display the status of the zones. The following table lists the various circumstances that the indicators will display (i.e., Zone Sealed, Zone Unsealed).

Indicator	Definition
On	Zone Is Unsealed
Off	Zone Is Sealed
Flashing Fast (0.25 Sec On – 0.25 Sec Off)	Zone Is In Alarm Condition
Flashing Slow (1 Sec On – 1 Sec Off)	Zone Is Manually Isolated

Table 147: Zone Indicators

Area On/Off Indicators

2

The group of four Area On/Off indicators (1 – 4) show the status of each area (i.e.. If an indicator is illuminated, that area is armed and if the indicator is not illuminated, that area is disarmed).

If an area is armed in STAY Mode 1, the corresponding Area On/Off indicator will be illuminated in conjunction with the PARTIAL indicator. If the area is armed in AWAY Mode, only the corresponding Area On/Off Indicator will be illuminated.

<i>Area On/Off Indicator</i>	<i>Definition</i>
On	Area Is Armed In AWAY Mode Or STAY Mode 1
Off	Area Is Disarmed

Table 148: Area On/Off Indicators

Area Display Indicators

3

A group of four Area Display Indicators indicate which area is currently being displayed (i.e.. If number 1 is being displayed, all information provided on the display relates only to Area 1. If number 2 is being displayed, all information provided on the display relates only to Area 2).

Pressing the **AWAY** button will toggle or move you to the next area display (i.e.. If Area 1 is currently being displayed, pressing the **AWAY** button will toggle or move you to Area 2. Pressing the **AWAY** button a second time will toggle you back to display information for Area 1).

<i>Area Display Indicators</i>	<i>Definition</i>
On	Indicates Current Area Being Displayed
Off	Indicates Current Area Not Being Displayed

Table 149: Area Display Indicators

Status Indicators

4

A group of four indicators display the following:

PARTIAL Indicator

The PARTIAL indicator is used to display that the system is armed in STAY Mode 1. The PARTIAL indicator will also flash in unison with the AUX indicator when Installer's Programming Mode or Master Code Functions are used.

For the different methods of arming the system in STAY Mode 1, refer to page 42. Refer to Zone Options 1 on page 175 for information on setting zones to be automatically isolated in STAY Mode 1.

<i>Indicator</i>	<i>Definition</i>
On	System Is Armed In STAY Mode 1
Off	System Is Not Armed In STAY Mode 1

Table 150: Partial Indicator

AUX Indicator

If Option 8 in “LOCATION 444” on page 241 has been enabled, the AUX indicator will be used to display when the control panel is using the telephone line. The AUX indicator will also flash in unison with the PARTIAL indicator when Installer’s Programming Mode or Master Code Functions are used.

<i>Indicator</i>	<i>Definition</i>
On	System Is Armed In STAY Mode 1 Or STAY Mode 2
Off	System Is Not Armed In STAY Mode
Flashing	Zone Isolating Mode Or Setting STAY Mode 2 Zones

Table 151: AUX Indicator

MAINS Indicator

The MAINS indicator is used to display that the systems AC mains supply is normal or has failed.

When programming numbers (i.e. Installer’s Programming Mode or Master Code Functions), the MAINS indicator will illuminate when you program numbers between 10 and 15. The MAINS indicator represents digit 10 plus the value of the illuminated zone indicator (e.g.: If you program a twelve, the MAINS indicator and zone 2 will illuminate).

<i>Indicator</i>	<i>Definition</i>
On	AC Mains Power Normal
Flashing	AC Mains Failure

Table 152: MAINS Indicator

FAULT Indicator

The FAULT indicator is used to display that the system has detected a system fault. Refer to Fault Analysis Mode on page 95 for more information on system faults.

Every time a new system fault has been detected (e.g.: FAULT indicator flashing), the codepad will begin to beep once every minute.

Pressing the button once will cancel the once a minute beep and acknowledge the fault (e.g.: FAULT indicator on).

<i>Indicator</i>	<i>Definition</i>
On	There Is A System Fault That Needs To Be Rectified
Off	The System Is Normal, There Are No Faults
Flashing	There Is A System Fault Waiting To Be Acknowledged

Table 153: FAULT Indicator

Audible Indicators

In general, the audible indications given out by the codepad are as follows:

<i>Indicator</i>	<i>Definition</i>
One Short Beep	A Button Has Been Pressed On The Codepad Or End Of Exit Time When Armed In Either STAY Mode 1 Or STAY Mode 2
Two Short Beeps	The System Has Accepted Your Code
Three Short Beeps	The Requested Function Has Been Executed
One Long Beep	Indicates The End Of Exit Time In AWAY Mode Or The Requested Operation Has Been Denied Or Aborted
One Short Beep Every Second	Walk Test Mode Is Currently Active Or Warning Before Automatic Arming Takes Place
One Short Beep Every Two Seconds	Telephone Monitor Mode Is Active
One Short Beep Every Minute	There Is A System Fault Waiting To Be Acknowledged

Table 154: Audible Indications

Operating Codepads In Partitioning

Operating From A CP5 Area Addressable LED Codepad

When operating a CP5 Area Addressable (CP500A) codepad in a system that has been partitioned, the display and operations are exactly the same as the CP5 Eight Zone LED codepad except that the commands issued from the codepad only effects the area that the codepad is allocated to. Refer to System Operations on page 40 for more information on operating the system.

Example

If the codepad is allocated to Area 2, only user codes that have been allocated to Area 2 can operate the codepad. If user codes only have access to Area 1, entering their code at the Area 2 codepad will not work.

If you wish to determine which codepad you are currently operating, hold down the **8** button to determine which area that the codepad is allocated to (i.e.. If Zone 1 illuminates, the codepad is allocated to Area 1, if Zone 2 illuminates, the codepad is allocated to Area 2). Refer to Hold Down Functions on page 93 for more information.

Operating From A CP5 Master Partitioned Codepad

When operating a CP5 Master Partitioned (CP500P) codepad in a system that has been partitioned, all operations are the same as the CP5 Area Addressable codepad with one exception. All operations are only related to the Area Display that is being indicated on the codepad at the time (i.e.. If the Area Display illuminates number 2, the codepad is displaying information only for Area 2. Therefore, all operations will only effect Area 2).

Refer to System Operations on page 40 for more information on operating the system.

How To Move From One Area To The Next

1. Press the **AWAY** button.
The Area Display indicator will move to the next area display (i.e.. If the Area Display illuminates number 1, pressing the **AWAY** button will toggle to display Area 2. Pressing the **AWAY** button a second time will toggle the display back to Area 1).

Programming

The following locations area only applicable when partitioning the *Solution Ultima 880* control panel. Remember that when programming option bit locations, you may add the options together (e.g.: If you require both options 2 and 4, you would add the two options together and program a 6).

Partitioning Options 1

LOCATION 444



Option	Description
1	First To Open/Last To Close Reporting
2	Area 1 Codepad Connected To Data Terminal
4	Reset Sirens From Any Area Allowed
8	Master Codepad To Display AUX Indicator When On-Line

Table 155: Partitioning Options 1

First To Open/Last To Close Reporting

- 1 This option needs to be enabled if only one Open/Close report is required when the system has been partitioned. Rather than having individual Open/Close reports fore each area, a closing report will be sent only when BOTH areas have been armed and an opening report will be sent as soon as one area has been disarmed.

The reports will be sent on the Subscriber ID Number allocated to that particular area. Subscriber ID Numbers and Open/Close reports must be programmed for both areas.



The option of first to open/last to close reporting is only applicable when all user codes have their priority level set with no open/close reports. Therefore, if user codes have priority levels set to open/close reports, an opening or closing report will always be reported when any area is disarmed or armed irrespective of which area was first to open or last to close.

Area 1 Codepad Connected To Data Terminal

- 2 If this option has been enabled, the DATA terminal on the *Solution Ultima 880* control panel will be configured to send status information only relevant to Area 1. This allows you to connect an area addressable codepad (CP500A) set for Area 1 operation to the DATA terminal of the control panel instead of connecting the addressable codepad to an output.

If this option has not been enabled, the CP5 Master Partitioned (CP500P) codepad will need to be used as the DATA terminal on the control panel would display information for both Area 1 and Area 2.

An advantage in using this option is that it allows you to configure a system into separate areas while still leaving the maximum number of programmable outputs available for other applications.

Reset Sirens From Any Area Allowed

4 This option is only applicable when the control panel has been partitioned. If this option has been enabled, any valid user code from either Area 1 or Area 2 will be able to reset the horn speaker, strobe, bell or EDMSAT outputs from operating. This option does not allow a user code allocated from one area to disarm another area.

Master Codepad To Display AUX Indicator When On-Line

8 If this option has been enabled, the AUX indicator on the CP5 Master Partitioned (CP500P) codepad will illuminate when the control panel has seized the telephone line to send a report. The AUX indicator will extinguish once the telephone line has been released.

Partitioning Options 2

LOCATION 445



<i>Option</i>	<i>Description</i>
1	Lock Area 1 To Receiver 1 and Lock Area 2 To Receiver 2
2	User Code Allowed To Arm/Disarm Both Areas At Same Time (Code + 0 + #)
4	Reserved
8	Reserved

Table 156: Partitioning Options 2

Lock Area 1 To Receiver 1 and Lock Area 2 To Receiver 2

1 If this option has been selected, it will automatically set all reports for Area 1 to Receiver 1 and all reports for Area 2 to Receiver 2.

If this option has not been selected, all reporting will need to be manually programmed to report on Receiver 1 or Receiver 2 for both areas.

User Code Allowed To Arm/Disarm Both Areas At Same Time

2 If this option has been selected, it will allow any user allocated to both areas to arm or disarm both areas at the same time without the need to enter the code at each area codepad. Refer to Arm or Disarm Both Areas At The Same Time on page 76 and 92 for more information.

If the user arms both areas at the same time, if in “LOCATION 444” on page 241 has the option “First To Open/Last To Close Reporting” enabled, only a closing report for the Area 2 will be reported.

If the user disarms both areas at the same time, if in “LOCATION 444” on page 241 has the option “First To Open/Last To Close Reporting” enabled, only an opening report for Area 1 will be reported.

Reserved

4

Reserved

8

Zone Allocations

Each area can have up to eight zones allocated to it. The eight locations for each area represents ZONE indicators one to eight on the remote area addressable codepad. Any of the zone inputs 1 – 8 can be mapped to any area to appear as any zone on the remote area addressable codepad (i.e.. Any zone can be programmed to both Area 1 and Area 2 to become common zones).

Zones that have been programmed as common zones (e.g.: Allocated to both Area 1 and Area 2) will report to the base station receiver on group zero (i.e. Area 1 = Group 1 and Area 2 = Group 2). Zones that are allocated only to one area will report on the corresponding group number. Common zones that are programmed other than 24 hour zone types will not activate an alarm until both areas have been armed in either AWAY Mode or STAY Mode 1.

Zone Allocations For Area 1

LOCATION 446 - 453

○○○○○○○○○

<i>Location</i>	<i>Description</i>
446	Area 1 – Zone 1 Indicator
447	Area 1 – Zone 2 Indicator
448	Area 1 – Zone 3 Indicator
449	Area 1 – Zone 4 Indicator
450	Area 1 – Zone 5 Indicator
451	Area 1 – Zone 6 Indicator
452	Area 1 – Zone 7 Indicator
453	Area 1 – Zone 8 Indicator

Table 157: Solution Ultima 880 – Zone Allocations For Area 1

Zone Allocations For Area 2

LOCATION 454 - 461

○○○○○○○○○

<i>Location</i>	<i>Description</i>
454	Area 2 – Zone 1 Indicator
455	Area 2 – Zone 2 Indicator
456	Area 2 – Zone 3 Indicator
457	Area 2 – Zone 4 Indicator
458	Area 2 – Zone 5 Indicator
459	Area 2 – Zone 6 Indicator
460	Area 2 – Zone 7 Indicator
461	Area 2 – Zone 8 Indicator

Table 158: Solution Ultima 880 – Zone Allocations For Area 2

Example

In this example, zones 1, 2, 3 and 4 have been allocated to Area 1 to appear as zones 1, 2, 3 and 4. Zones 1, 5, 6, 7 & 8 have been allocated to Area 2 to appear as zones 1, 5, 6, 7 and 8. Programming the same zone into more than one area indicates that the zone will operate as a common zone.

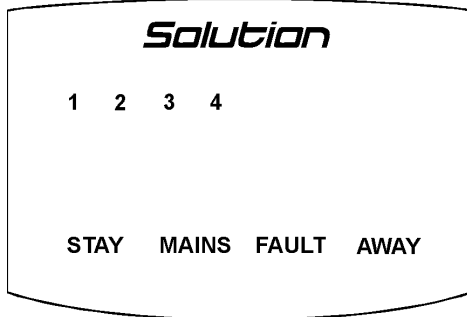

Figure 14: Area 1 Codepad Display

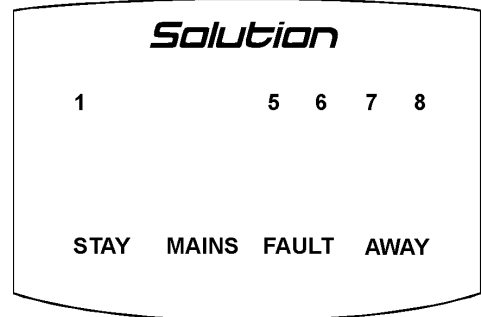

Figure 15: Area 2 Codepad Display

Area 1 Zone Allocations
LOCATION 434 – 441
1 2 3 4 0 0 0 0

Area 2 Zone Allocations
LOCATION 442 – 449
1 0 0 0 5 6 7 8

User Code Allocations

“LOCATION 462 – 477” is used to assign each user code to an area or multiple areas when the *Solution Ultima 880* control panel has been partitioned. A number 0 – 3 is required to be entered into each of these locations to assign each user code holder to the areas they are required to operate. Multiple user codes can be allocated to the same areas.

Select the required areas that the user code holder is to operate and then add the options values together from “Table 159: User Code Allocations” below (e.g.: If the user code is allocated to operate both Area 1 and Area 2, program a 3 (i.e.. 1 + 2 = 3) into the required location relevant to their user code allocation. If the user code is allocated only to Area 1, program their user code allocation as 1).

<i>Option</i>	<i>Allocated Areas</i>
0	Not Allocated To An Area
1	Allocated To Area 1
2	Allocated To Area 2
3	Allocated To Area 1 + Area 2

Table 159: User Code Allocations

Location 462 User Code 1	Location 463 User Code 2	Location 464 User Code 3	Location 465 User Code 4
Location 466 User Code 5	Location 467 User Code 6	Location 468 User Code 7	Location 469 User Code 8
Location 470 User Code 9	Location 471 User Code 10	Location 472 User Code 11	Location 473 User Code 12
Location 474 User Code 13	Location 475 User Code 14	Location 476 User Code 15	Location 477 User Code 16

Setting Up and Programming Codepads For Partitioning

Only the CP5 Area Addressable (CP500A) and CP5 Master Partitioned (CP500P) codepads can be used when partitioning a *Solution Ultima 880* control panel.

Setting Up The Master Partitioned Codepad As The Main Codepad.

If you are using the CP5 Master Partitioned (CP500P) codepad as the main codepad when partitioning, you need to connect the codepad to the main codepad terminals (CP-, CP+, CLK and DATA). All DIP switches on the back of the codepad will need to be set to the ON position.

Setting Up An Area 1 Codepad As The Main Codepad

If you are not using the CP5 Master Partitioned codepad as the main codepad of the partitioned system, you need to connect the Area 1 codepad to the main codepad terminals (CP-, CP+, CLK and DATA). In addition to setting up the Area 1 Codepad, you will need to set DIP switch 1 on the back of the codepad into the ON position and enable Option 2 in "LOCATION 444" on page 241.

Setting Up An Area 1 Codepad

If you wish to have a separate area codepad only for Area 1 when using the CP5 Master Partitioned codepad as the main codepad, you will need to connect the Area 1 codepad to the main codepad terminals (CP-, CP+ and CLK) with the DATA terminal to be connected to one of the programmable outputs programmed as "6,0 – Area 1 Codepad Data". DIP switch 1 on the back of the Area 1 codepad will need to be in the ON position.

Setting Up An Area 2 Codepad

If you wish to have a separate area codepad only for Area 2, you will need to connect the Area 2 Codepad to the main codepad terminals (CP-, CP+ and CLK) with the DATA terminal to be connected to one of the programmable outputs programmed as "6,1 – Area 2 Codepad Data". DIP switch 2 on the back of the Area 2 codepad will need to be in the ON position.

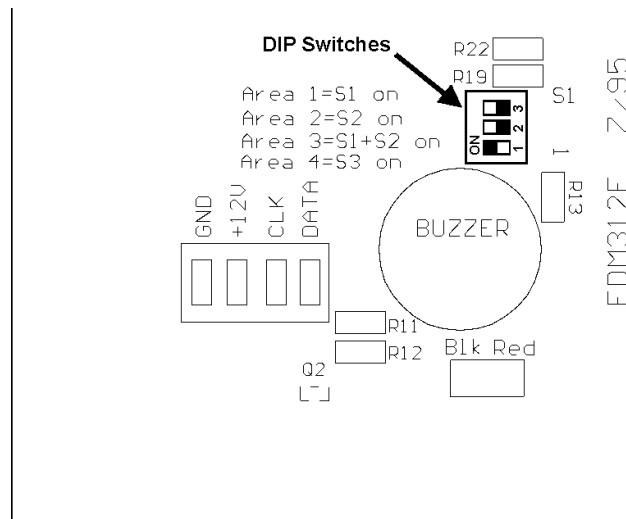
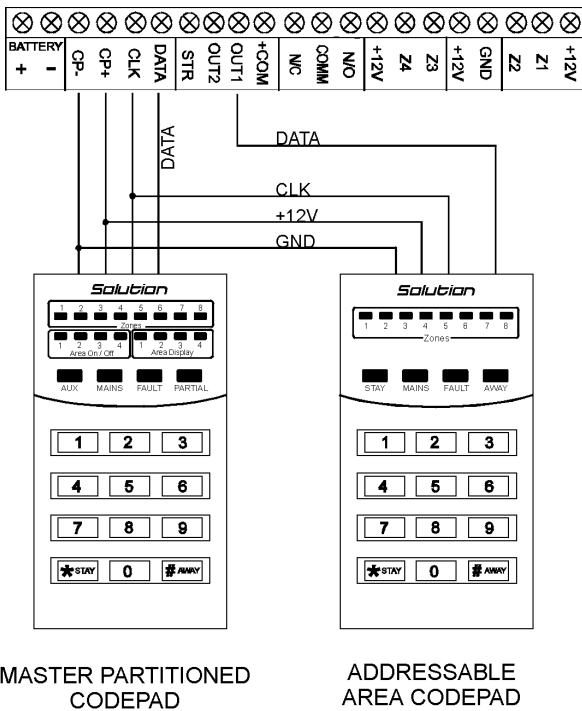

Figure 16: DIP Switch Location On Back Of Codepad PCB

Codepad Connections For Partitioning - Examples



If the CP-5 Area Addressable (CP500A) codepad is assigned to **Area 1**, DIP Switch 1 on the back of the remote codepad will need to be in the ON position. The following locations for Output 1 will need to be programmed.

[LOCATION 380 = 6, 381 = 0]

If the CP-5 Area Addressable (CP500A) codepad is assigned to **Area 2**, DIP Switch 2 on the back of the remote codepad will need to be in the ON position. The following locations for Output 1 will need to be programmed.

[LOCATION 380 = 6, 381 = 1]

Figure 17: Connections For CP-5 Master Partitioned (CP500P) Codepad and CP-5 Area Addressable (CP500A) Codepad

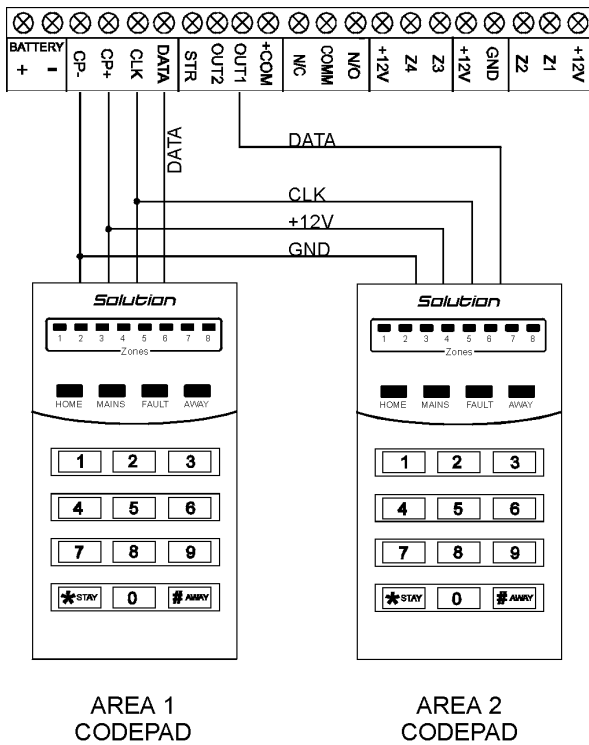

The following DIP Switch settings and locations must be programmed for the two CP-5 Area Addressable (CP500A) codepads to function correctly.

AREA 1 CODEPAD

DIP Switch 1 on the back of the remote codepad will need to be in the ON position. The following location will also need to be programmed.

[LOCATION 444, Option bit 2 must be enabled]

AREA 2 CODEPAD - (Output 1)

DIP Switch 2 on the back of the remote codepad will need to be in the ON position. The following locations for Output 1 will need to be programmed.

[LOCATION 380 = 6, 381 = 1]

Figure 18: Connections For Two CP-5 Eight Zone Area Addressable (CP500A) Codepads

RF Information

This section includes the following:

- *RF Option Bit*
- *RF Device Mapping (Devices 1 – 8)*
- *RF Device Mapping (Devices 9 – 16)*
- *RF Device Signal Strength (Devices 1 – 8 Read Only)*
- *RF Device Signal Strength (Devices 9 – 16 Read Only)*

LOCATION 527



<i>Option</i>	<i>Description</i>
1	Sound Siren On RF Receiver Fail
2	Sound Siren On RF Receiver Tamper / Jamming
4	Unseal Zone That Fails Supervision (If Supervision Enabled)
8	Enable RF Jamming Monitoring

Table 160: RF Option Bit

Sound Siren On RF Receiver Fail

1 If this option has been programmed, the horn speaker, piezo and strobe will operate when the RF receiver fails to communicate to the control panel.

Sound Siren On RF Receiver Tamper / Jamming

2 If this option has been programmed, the horn speaker, piezo and strobe will operate when the tamper switch on the receiver has become open circuit or the receiver has picked up jamming signals from a RF device.

Unseal Zone That Fails Supervision

4 If a wireless zone device fails to send a signal within the RF Supervision Time programmed in LOCATION 337 on page 187, the control panel will force the zone indicator on the codepad to display as unsealed.

Enable RF Jamming Monitoring

8 If this option has been enabled, the RF receiver will monitor the background RF levels. If this level reaches a preset limit, the receiver will assume it is being jammed. This will generate a fault on the codepad and will also send an “RF Jamming” report back to the monitoring station.

RF Device Mapping (Devices 1 – 8)

LOCATION 528 - 535

1 2 3 4 5 6 7 8

These locations allow you to allocate RF wireless devices 1 – 8 to any of the available 8 zones on the control panel. More than one RF wireless device may be mapped to the same zone. Refer to “LOCATION 536 - 543” to map RF wireless devices 9 – 16 to any of the available 8 zones on the control panel. At factory default, RF devices 1 – 8 are mapped separately to each of the available 8 zones (e.g.: Device 1 is mapped to Zone 1, Device 2 is mapped to Zone 2 etc).

RF Device Mapping (Devices 9 – 16)

LOCATION 536 - 543

○ ○ ○ ○ ○ ○ ○ ○

These locations allow you to allocate RF wireless devices 9 – 16 to any of the available 8 zones on the control panel. More than one RF wireless device may be mapped to the same zone. Refer to “LOCATION 528 - 535” to map RF wireless devices 1 – 8 to any of the available 8 zones on the control panel.

RF Device Signal Strength (Devices 1 – 8 Read Only)**LOCATION 801 - 808**

These locations allow you to view the signal strength received for each of the RF wireless devices 1 – 8 (e.g.: LOCATION 801 will display the signal strength of Device 1, LOCATION 802 will display the signal strength of Device 2 etc). Zero is the lowest signal strength and eight is the highest signal strength.

RF Device Signal Strength (Devices 9 – 16 Read Only)**LOCATION 809 - 816**

These locations allow you to view the signal strength received for each of the RF wireless devices 9 – 16 (e.g.: LOCATION 809 will display the signal strength of Device 9, LOCATION 810 will display the signal strength of Device 10 etc). Zero is the lowest signal strength and eight is the highest signal strength.

Optional Equipment

This section includes the following:

- *2 Channel/4 Channel Hand Held Transmitters 304 MHz (RE012/RE013)*
- *2 Channel Radio Interface (RE005)*
- *EDMSAT - Satellite Siren (SS914)*
- *Programming Key (CC891)*
- *Alarm Link Software (CC816)*
- *CP5 Eight Zone LED Codepad (CP508)*
- *CP5 Eight Zone LCD Codepad (CP508L)*
- *CP5 Eight Zone Area Addressable Codepad (CP500A)*
- *CP5 Master Partitioned LED Codepad*
- *Night Arm Station (CP105)*
- *Phone Controller (CC911)*
- *Hand Held Dialler Tester (DD901)*
- *Cellular Diallers*
- *PS100 Power Supply Module (PS100)*
- *TF008 Plug Pack (TF008)*
- *Solution Codepad Mimic Board (CC820)*
- *2 Wire Smoke Detector Interface (FA101)*
- *Radio Key/Keyswitch Interface (CC813)*

Optional Equipment

EDM manufactures numerous accessories that can be used in conjunction with the *Solution Ultima 844/862/880* control panel. These optional pieces of equipment will enhance certain features thus making the system extremely flexible.

2 Channel/4 Channel Hand Held Transmitters 304 MHz (RE012/RE013)

These hand held radio Transmitters can be used in conjunction with the 304 MHz RF Receiver (RE005) to remotely operate the system. Both hand held Transmitters have the ability to remotely arm and disarm the system in AWAY Mode or STAY Mode 1 and activate remote panic alarms. The 4 channel hand held Transmitter has the added ability to operate outputs such as garage doors, swimming pool pumps or outside lights etc.

2 Channel Radio Interface (RE005)

The EDM 2 channel radio interface has been designed to allow customers to remotely operate Solution control panels and control two on-board relays. The interface may also be used as a stand alone receiver, independent of a Solution control panel and used solely for remote control of external devices connected to the two on-board relays.

The interface's operating frequency is 304 MHz with the ability to store up to 120 radio remote codes. When connecting the interface to a Solution control panel, there is only a three wire connection in parallel to the codepad and Option 8 in "LOCATION 439" on page 230 needs to be programmed.

EDMSAT - Satellite Siren (SS914)

The EDMSAT Satellite Siren is a totally self contained unit incorporating a high powered siren and a weatherproof strobe. A 1.2 AH sealed lead acid battery needs to be fitted. The EDMSAT requires only two wires for operation on which the charging of the battery and triggering of the siren and strobe are carried out. This is done by pulse code modulating (PCM) the charging voltage. Any attempt to tamper with the wiring or to substitute an alternative power source across the wiring will disrupt the data transmission and the EDMSAT will activate immediately. When the EDMSAT carries out a battery test, the unit will sound for two seconds if the battery test fails. Refer to the Output Event Type – EDMSAT - Satellite Siren on page 202 when programming a programmable output for the satellite siren.

Hand Held Programmer (CC814)

The hand held programmer is used to program the locations in the *Solution Ultima 844/862/880* control panel. The unit displays the actual location number and the data value currently programmed. It comes complete with a one metre connecting cable and a socket for an external programming key. Refer to Programming With The Hand Held Programmer on page 105 for more information.

Programming Key (CC891)

The programming key is a unique device that will store all programming information programmed in your control panel once copied to the programming key. The programming key can hold all your common configuration data such as monitoring station telephone numbers and zone reporting channels etc.

Alarm Link Software (CC816)

This software package is designed to be used for programming the *Solution Ultima 844/862/880* control panel by either the direct connect method or the remote connect method via the telephone line. All options and features can be accessed using this software as well as maintaining history and service reports. Refer to "LOCATION 180" on page 124 or 156 to enable this feature. Refer to Alarm Link Software on page 122 for more information on the remote connect methods.

CP5 Eight Zone LED Codepad (CP508)

This codepad is designed to operate with the *Solution* range of control panels. This codepad provides indications for up to 8 zones. This codepad cannot be used with the *Solution Ultima 880* control panel when partitioned.

CP5 Eight Zone LCD Codepad (CP508L)

This codepad is designed to operate with the *Solution* range of control panels with a fixed icon display. This codepad provides indications for up to 8 zones. This codepad cannot be used with the *Solution Ultima 880* control panel when partitioned.

CP5 Eight Zone Area Addressable Codepad (CP500A)

This codepad is designed to operate with the *Solution Ultima 880* control panels when partitioned. These codepads have DIP switches on the back of the codepad to select which area in partitioning that the codepad belongs to. Refer to Setting Up and Programming Codepads For Partitioning on page 246 and Codepad Connections For Partitioning on page 247 for more information.

CP5 Master Partitioned Codepad (CP500P)

This codepad is designed to operate with the *Solution Ultima 880* control panels when partitioned. These codepads allow the entire system to be operated from the single codepad allowing the user to toggle between separate areas by pressing the **AWAY** button. This means that there is no need to have separate CP5 Area Addressable (CP500A) codepads for each area. Refer to Setting Up and Programming Codepads For Partitioning on page 246 and Codepad Connections For Partitioning on page 247 for more information.

Night Arm Station (CP105)

The night arm station incorporates a panic button and is designed to allow system operation from a bedroom or sitting room to arm and disarm the system in STAY Mode 1. Refer to Option 8 in "LOCATION 439" on page 230 to enable the night arm station to operate with the system.

Phone Controller (CC911)

The phone controller operates at a frequency of 1400 Hz and allows the user to remotely arm the system in AWAY Mode via the telephone. This phone controller can also be used to acknowledge a phone call from the control panel when the system is set up for domestic dialling.

Hand Held Dialler Tester (DD901)

The hand held dialler tester simulates a base station for testing of the control panel's dialling functions. It communicates in most formats.

Cellular Diallers

The cellular dialler when connected to the control panel will send alarm information via the cellular phone network to the base station receiver when a land telephone line is not present or has been tampered with.

PS100 Power Supply Module (PS100)

The PS100 Power Supply Module has been designed for applications requiring 13.8 volts DC at currents of up to 1 Amp and must be used in conjunction with the TF008 - 18 volt AC plug pack.

The unit comes complete with our standard, fully short circuit proof, power out and battery charging terminals as well as a DC LED indicator and AC mains fail output. For situations requiring an uninterrupted power source, a rechargeable sealed lead-acid battery can be connected. In the event of an AC mains failure, the power supply will switch to battery power without interrupting the load being supplied.

TF008 Plug Pack (TF008)

The TF008 plug packs have been designed to be used with the EDM control panels and the PS100 Power Supply Module. The plug pack includes built in thermal fuses that under overload or fault conditions will blow and eliminate any possible fire threat due to excessive heat build up inside the casing.

The TF008 plug pack incorporates a three wire flying lead that enables a mains earth connection to be made between the equipment and the plug pack. This connection may be required for lightning protection on equipment that is connected to phone lines or for safety reasons such as earthing of metal enclosures.

Solution Codepad Mimic Board (CC820)

The Solution Codepad Mimic Board (CC820) has been designed to allow you to have a separate output indicator for each indicator found on the remote codepad. This will be useful to remotely display system status information.

2 Wire Smoke Detector Interface (FA101)

The 2 Wire Smoke Detector Interface (FA101) has been designed to allow high quality 2 wire, 24 volt DC smoke detectors to be easily connected to the Solution range of control panels. The interface provides the 24 volts required to power the smoke detector and also provides a relay output that is used to trigger the control panel. Multiple detectors may be connected to the same interface.

Radio Key/Keyswitch Interface (CC813)

This interface was designed to allow simple interfacing of a momentary keyswitch or radio equipment for remote control operations to operate the control panel.

If the R/K terminal is used, a number of momentary keyswitches may be connected in parallel for multiple arm/disarm locations. The ON and OFF terminals can be used to directly interface to any access control system.

The HOME terminal will force the system to arm and disarm in STAY Mode 1.

There is also a PANIC terminal that allows the customer to issue a panic alarm from a remote keyswitch or hand held radio Transmitter.

This is handy if you require your system to be radio controlled and you would like to give your customer total control via a hand held radio remote.

Terminals and Descriptions

This section includes the following:

- *Terminal Definitions and Descriptions*
- *Glossary Of Terms*
- *Solution Ultima 844/862/880 Wiring Diagram*
- *Solution Ultima 844/862/880 Component Overlay*
- *Telecom Connection Diagrams*

Terminal Definitions and Descriptions

Terminal	Description
<i>EARTH</i>	This terminal should be connected to the green wire on the TF008 Plug Pack that is internally connected to the mains earth. Extensive lightning protection has been built into the control panel and this terminal will have to be connected correctly if you are to take the best advantage of the protection provided.
<i>18VAC</i>	These two terminals are plug on type, and are the termination point for the TF008 Plug Pack. The voltage of the plug pack being used must be 18 - 22 volts AC and rated at 1.3 Amps minimum for correct operation.
<i>+BATTERY</i> <i>-BATTERY</i>	The + BATTERY connects to the red positive terminal of the battery and the - BATTERY connects to the black negative terminal of the battery. The battery should be a 12 volt sealed lead acid rechargeable type with a capacity of between 1.2 AH - 6.5 AH. The back-up battery is protected by a 3 Amp fuse. The charging globe which is situated above the 3 Amp fuse will always be illuminated until the battery is 100% charged.
<i>GND</i> <i>+12V</i> <i>CLK</i> <i>DATA</i>	This group of terminals are the connection points for your system codepads. All system codepads should connect in a parallel configuration back to these terminals. The only factor restricting the number of codepads that can be connected is the available power and its distribution. Each codepad has a maximum power requirement of 60 mA with all indicators illuminated, therefore this should be taken into consideration when calculating your available continuous power. The total continuous external load on the system should not exceed 1 Amp maximum.
<i>STR</i> <i>OUT 1</i> <i>+COM</i>	This group of terminals are the output interface terminals. They can be configured to any combination of the functions available via the system programming options. They can be used for a variety of functions with incredible flexibility. All outputs have a common terminal that is positive 12 volts and each output is capable of sinking a maximum of 400 mA. Output 1 is defaulted to operate a horn speaker. The outputs are protected by EDM's unique Integrated Protection System, [IPS]. This makes them extremely tolerant to abuse or incorrect wiring. It should be noted that each output is open collector and will not source any current but can sink a maximum of 400 mA per output.
<i>COMM</i> <i>N/O</i>	These relay contacts are fully programmable as with the strobe and output 1. The relay is factory defaulted as an alarm output (Sirens Running - Event Type 1,15). The N/O contact is the connection point for the positive side of a DC siren such as a piezo screamer. The negative side of the DC siren needs to be connected to the GND terminal. A link (JP2) is provided on the PCB for connecting the COM terminal to either GND or 12V. This link should be connected to +12V as shown in "Figure 19: Solution Ultima 844/862/880 Wiring Diagram" on page 262. The relay is rated at 1 Amp/30 VDC.
<i>+12V</i> <i>Z4</i> <i>Z3</i>	These terminals are zones three and four. Their common terminal is +12V. All normally closed contacts are to be wired in series with the EOL resistor and where normally open contacts are to be wired in parallel with the EOL resistor. The function of the zones and their response times are programmable via the system programming options. If split EOL has been programmed, this will enable 24 hour zones or keyswitch zones to be connected in parallel to zones three and four to act as zones seven and eight.
<i>+12V</i> <i>GND</i>	These two terminals are for power to detectors and other equipment. They are fuse protected by a 1 amp fuse.
<i>Z2</i> <i>Z1</i> <i>+12V</i>	These terminals are zones one and two. Their common terminal is +12V. All normally closed contacts are to be wired in series with the EOL resistor and where normally open contacts are to be wired in parallel with the EOL resistor. The function of the zones and their response times are programmable via the system programming options. If split EOL has been programmed, this will enable 24 hour zones or keyswitch zones to be connected in parallel to zones one and two to act as zones five and six

Glossary Of Terms

<i>Term</i>	<i>Description</i>
<i>Alarm Condition</i>	Is when your alarm system is armed and one of the detection devices are violated. A 24 hour zone (e.g.. Smoke detector) may trigger when your system is armed or disarmed.
<i>Answering Machine Bypass</i>	Answering machine bypass has been incorporated so that it is possible to make a connection with the control panel for remote arming or remote programming operations when there is an answering machine or facsimile machine on the same telephone line.
<i>Armed (System ON)</i>	When the system is in a state ready to accept alarms.
<i>Automatic Arming</i>	Automatic arming allows the system to automatically arm at the same time each day in AWAY Mode or STAY Mode 1.
<i>Automatic Disarming</i>	Automatic disarming allows the system to automatically disarm at the same time each day in AWAY Mode or STAY Mode 1.
<i>AWAY or #</i>	This is the button on your codepad used to execute any given command.
<i>AWAY Mode</i>	Is the mode used to arm your system when you leave your premises.
<i>Codepad</i>	The codepad allows you to perform all functions such as arming, disarming and programming of your alarm system.
<i>Day Alarm</i>	Day alarm allows a combination of zones to be monitored while the system is in the disarmed state.
<i>Detectors</i>	Are devices connected to your alarm system used to cause an alarm condition. Some common forms of detection devices are; passive infrared, smoke, photo electric beams, reed switches and vibration sensors.
<i>Dialler</i>	Is a device that is used for communicating to a monitoring station, mobile phone or pocket pager etc.
<i>Disarmed</i>	Is when your system is in a state that will not accept alarms except for 24 hour zones.
<i>Dual Reporting</i>	Dual reporting allows your control panel to send alarm signals in two different reporting formats (EG: The control panel may send to a monitoring station as well as a mobile phone etc or even to two different monitoring stations).
<i>Dynamic Battery Testing</i>	Is a feature used to monitor and test the condition of your backup battery.
<i>EDMSAT (Satellite Siren)</i>	Is a self contained siren unit complete with flashing blue strobe light and a backup battery. It offers a higher level of security for your alarm system.
<i>Entry Time or Entry Delay</i>	Is the time allowed after entering your premises, to disarm your system before an alarm occurs.
<i>Entry Warning</i>	Is the beeping from your codepad during entry time to remind you to disarm your system.

<i>Term</i>	<i>Description</i>
<i>Exit Time or Exit Delay</i>	Is the amount of time you have to leave your premises after you have armed your system.
<i>External Equipment</i>	Is any device connected to your system such as detectors, codepads and sirens.
<i>Forced Arming</i>	Is a situation where your alarm system is permitted to be armed when one or more zones are unsealed.
<i>Handover Delay</i>	When your system is armed and zone one is violated, the entry delay starts timing. If zone two is then violated the entry delay time is handed over to zone two and so on through zones three and four. This is known as sequential hand over delay.
<i>Hand Held Radio Remote Control</i>	Hand held radio Transmitters can be used to arm and disarm your system or cause a panic alarm.
<i>Lockout Dialler</i>	Lockout dialler means that the dialler will only activate once per zone per arming cycle.
<i>Lockout Siren</i>	Lockout siren means that the sirens will only activate once per zone per arming cycle.
<i>Master Code</i>	Is a numerical code used for arming and disarming the system as well as allowing access to all functions that are programmable through the codepad.
<i>Monitoring Station</i>	Is a secure location where a digital receiver monitors numerous alarm systems and deciphers their alarm transmission reports so that the operator can advise the appropriate authorities to take immediate action.
<i>Panic</i>	This is a type of alarm raised by you to indicate to the monitoring station that there is an emergency situation at your premises.
<i>Phone Controller</i>	Is a device used for arming your system via the telephone line. It is also used to acknowledge domestic alarm reports.
<i>Partitioning</i>	The <i>Solution Ultima 880</i> control panel may be set up to transform your single control panel and split the system into two separate controllable areas. Partitioning is extremely useful when you wish to secure sheds, dual occupancy dwellings, granny flats, shops and offices.
<i>Radio Remote User Codes</i>	A radio user code that is used to arm and disarm the system remotely via hand held Transmitters in AWAY Mode or STAY Mode 1. Remote panic alarms are also allowed.
<i>Sealed</i>	Refers to a zones status. If a zone is sealed, the detection devices are not violated and the zone indicator will be extinguished (i.e.. a reed switch is closed or a detector is on stand by waiting for an intrusion).
<i>Sensor Watch</i>	Sensor watch gives the control panel the ability to recognise that detection devices may have stopped working. This is a feature that monitors the operation of a zone over a programmed time period.
<i>Silent Alarm</i>	When programming your system, it is possible to have an individual zone for silent alarm. This means that when the zone is violated your alarm system will communicate with the monitoring station without sounding the sirens. This can only be programmed by your installer.

<i>Term</i>	<i>Description</i>
<i>STAY Mode 1</i>	Is a condition that automatically isolates certain zones when your system is armed in STAY Mode 1. These zones can only be programmed by your installer.
<i>STAY Mode 2</i>	Is a condition that automatically isolates certain zones when your system is armed in STAY Mode 2. These zones are programmed by the Master Code holder.
<i>Telco Arming Sequence</i>	Telco arming is a feature that automatically diverts your telephone number to another telephone when the system is armed in AWAY Mode - same as using call forwarding.
<i>Telco Disarm Sequence</i>	Telco disarm automatically un-diverts your telephone upon disarming your system.
<i>Unsealed</i>	Refers to zone status. If a zone is unsealed, the detection devices are violated and the zone indicator will be illuminated (i.e.. a reed switch is open or a detector has noted an intrusion).
<i>User Code</i>	A numerical code that is used to arm and disarm the system in AWAY Mode, STAY Mode 1 or STAY Mode 2.
<i>Zones</i>	A monitored input used to trigger an alarm condition. A zone may be set up only to activate an alarm when the system is armed or to operate irrespective of the system being armed or disarmed.
<i>24 Hour Zone</i>	A monitored input where tamper switches and emergency switches may be connected. If at any time, (whether your system is armed or disarmed) one of these switches is violated, an alarm condition will be generated.

Solution Ultima 844/862/880 Wiring Diagram

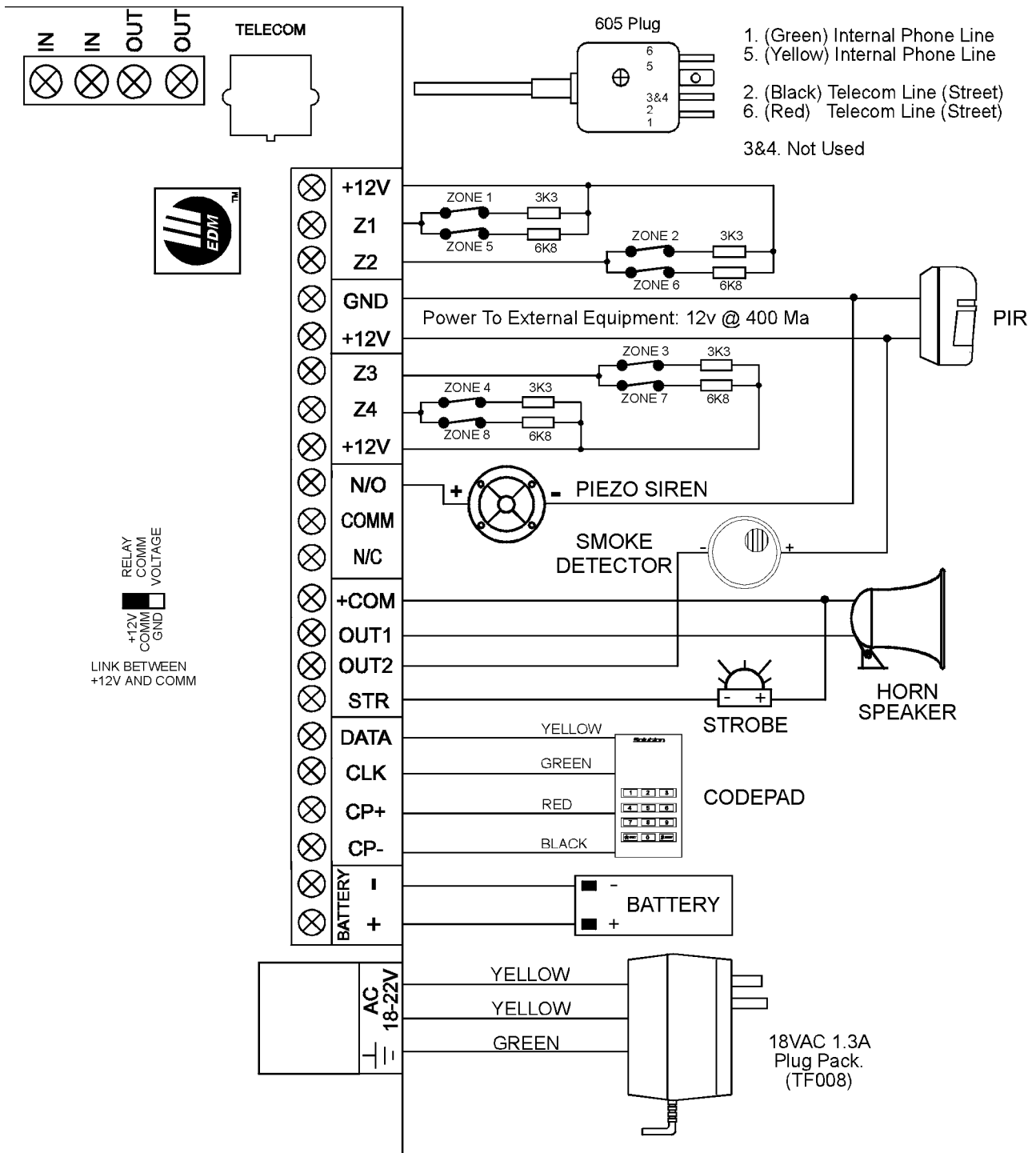

Figure 19: Solution Ultima 844/862/880 Wiring Diagram

Solution Ultima 844/862/880 Component Overlay

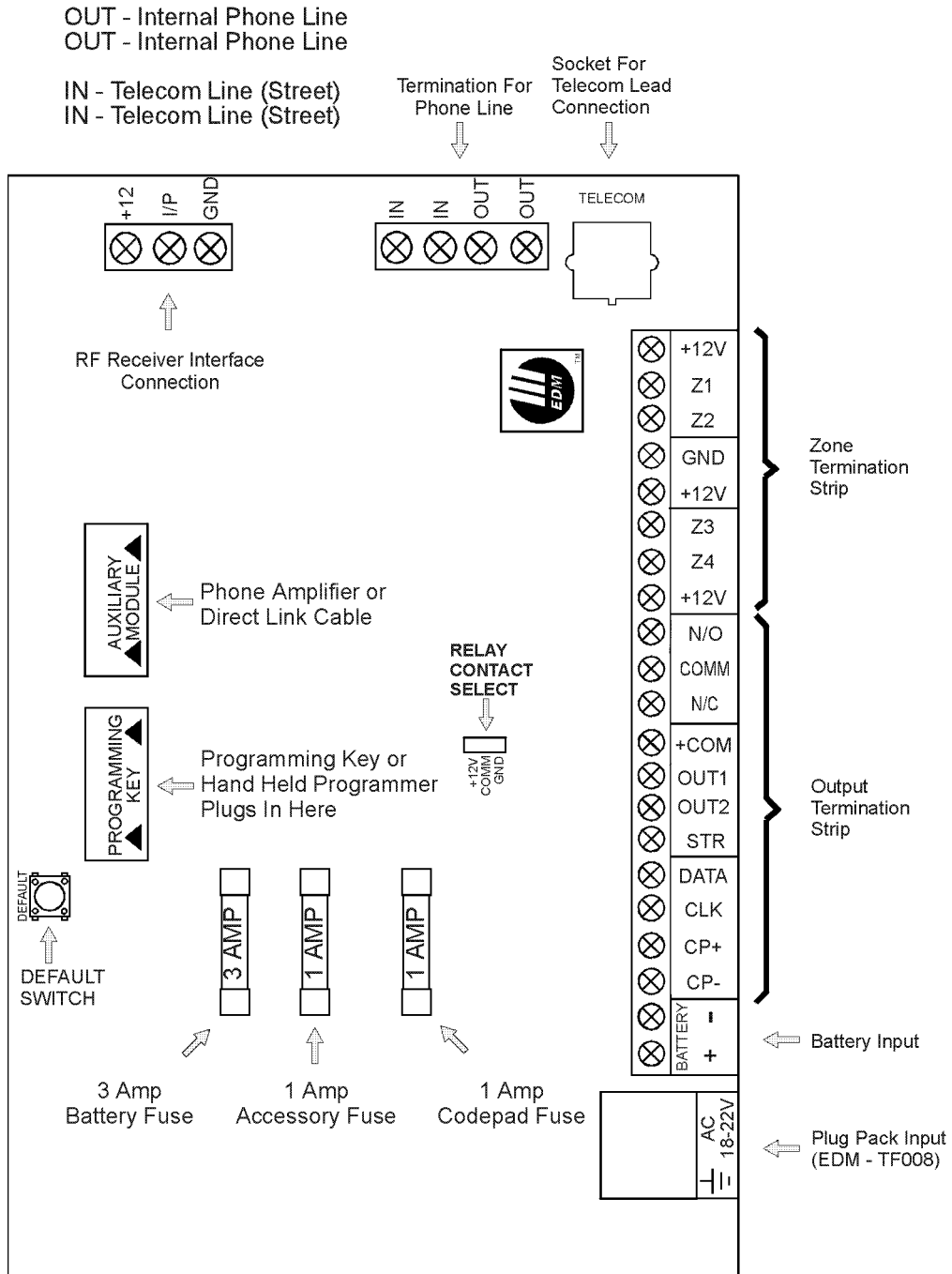
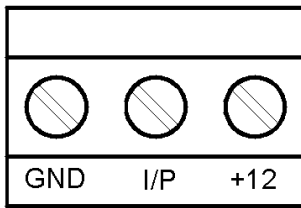

Figure 20: Solution Ultima 844/862/880 Component Overlay

RF3212 Radio Receiver Wiring Diagram

Solution Ultima Control Panel



RF Receiver (RF3212)

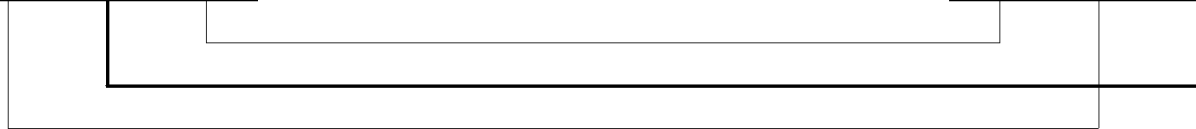
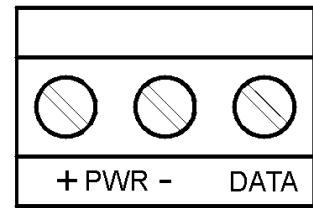

Figure 21: RF Receiver (RF3212) Wiring Diagram

Wiring and Power Up

- Remove power from the control panel.
- Connect the RF Receiver to the control panel as shown above using 0.8mm (22-gauge) or larger wire. Wire length should not exceed 300 meters (1000 feet).
- Apply power to the control panel. The red LED at the centre of the module will turn on.

Operation

The following describes the status of the module based on the LED condition.

LED On – Module is functioning normally.

LED Off – Power failure has occurred or module is not wired correctly.

LED Turns Off Momentarily – Module acknowledged receiving an RF signal from a remote RF device.

Telecom Connection Diagrams

TELECOM CONNECTION DIAGRAM FOR AUSTRALIA

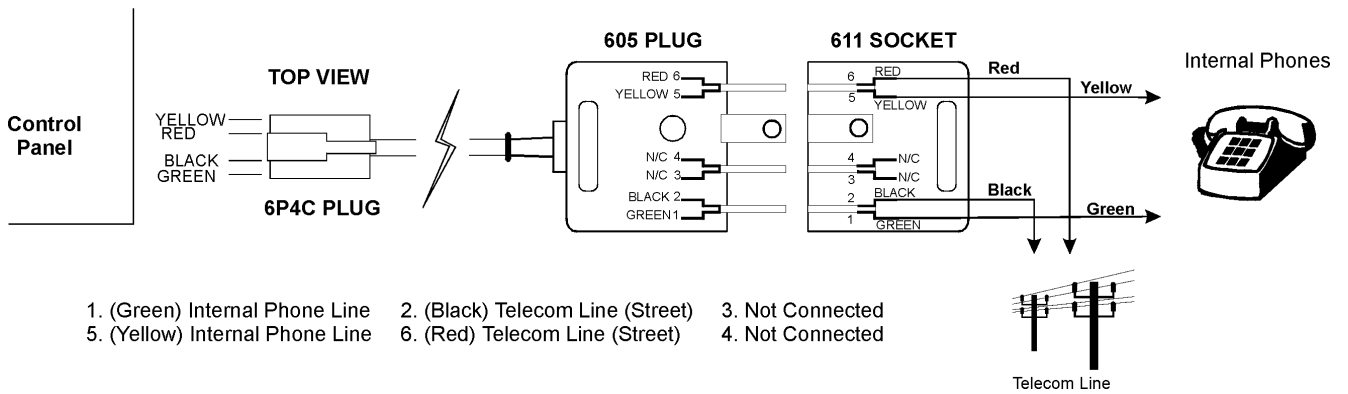

TELECOM CONNECTION DIAGRAM FOR NEW ZEALAND

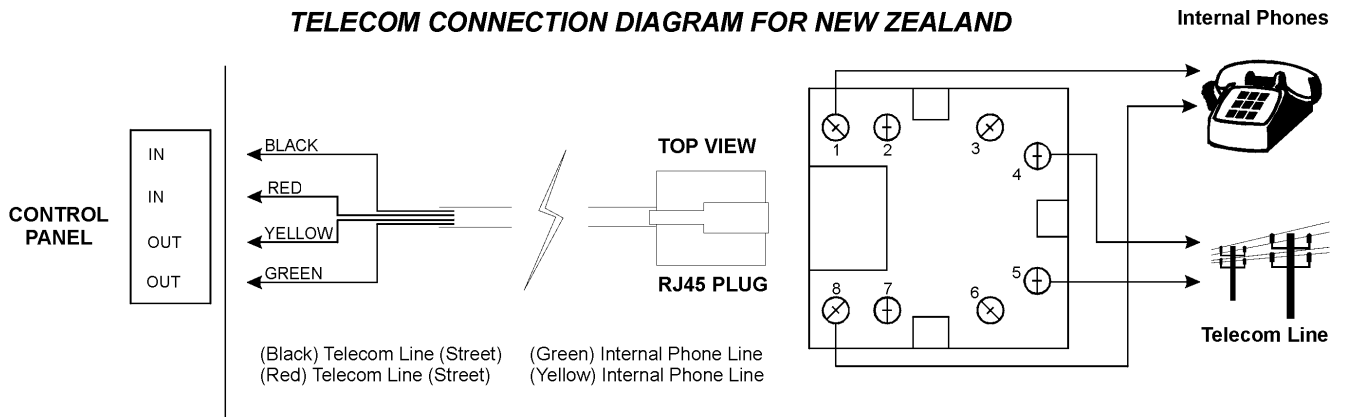

TELECOM CONNECTION DIAGRAM FOR CHINA

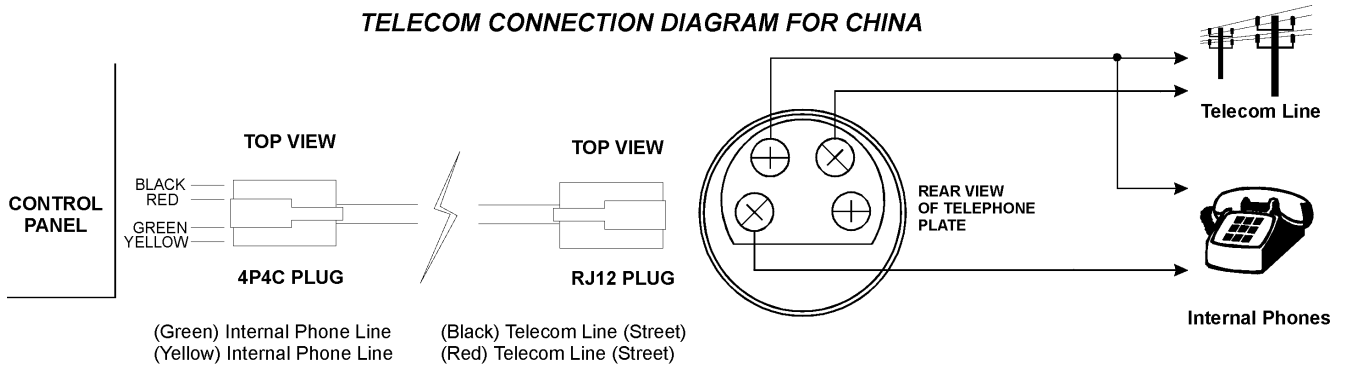

Figure 22: Telecom Connection Diagrams For Solution Ultima 844/862/880

Appendices

This section includes the following:

- *Telephone Anti-Jamming*
- *Test Reports Only When Armed*

Appendix A

Telephone Anti-Jamming

There are many companies today importing American designed products that claim to have Anti-Jamming and believe it or not, they push this feature as if it were a major break through in control panel technology. Well this in fact is not the case at all as most control panels have some sort of Anti-Jamming feature. We can go as far back as the early 1980's where even the 678 diallers incorporated a form of Anti-Jamming as a standard programmable option.

The important thing to note is that as most American designed products are primarily aimed at their local market and telephone networks, when they are imported to Australia their anti-jamming function does not perform as it should.

To clear up just what anti-jamming is and how it works needs some understanding of Telephone Networks. In America either of the two parties (i.e.. the one who initiated the call or the one receiving the call) can clear the line by placing the hand piece back on the hook. If you pick up the hand piece again, dial tone will be received and you will be able to make a new call immediately. This is not so here in Australia.

In Australia, only the calling party can immediately terminate the call. If you receive a call from someone and hang up on them, picking the hand piece back up again to make a new call only reconnects you to the original caller. It will not be possible to make another call until the original caller hangs up or you hang up phone for ninety seconds or longer. So you see Australia is very different and needs a special form of anti-jamming to suit our telephone network.

There are control panels on the market that after making a few call attempts which fail simply hang up and wait for ninety seconds or so, in an attempt to clear the jamming incoming call. This may work in some instances where the caller is not a genuine burglar and is not deliberately trying to jam the control panel. With this simple method of hanging up for ninety seconds we have not only delayed the alarm signal for this time but also the time taken for the original failed call attempts which could easily total 4 minutes. This is bad enough in its own right but even more disturbing is the fact that the initial failed call attempts allow for the establishment of an audio connection between the would be burglar and the control panel. Anyone with a little knowledge of alarm systems will be able to actually trick the dialler into thinking it is talking to a base station thus actually clearing the alarm signal. Pretty frightening when you thought the control panel you were using and recommending to your customers is supposed to have anti-jamming.

At Electronics Design and Manufacturing Pty Limited we take anti-jamming very seriously and have in fact devoted a great deal of time and money researching this problem. Our engineers have come up with the best possible anti-jamming procedure known and patented accordingly {Patent Number 571994}.

Our procedure is very simple and effective because we never answer the burglars phone call and the Telecom Network will automatically clear an unanswered call in approximately ninety seconds. This time will be even shorter if the call is originated through the Mobile-Net Network where it will most likely be in the case of a true burglary.

Once the control panel detects that the phone line has stopped ringing it immediately loops the line and makes its call therefore sending its alarm message successfully. The line is also automatically disconnected from the telephones within the protected premises immediately on an alarm condition by the control panel to further confuse the burglar and eliminate the possibility of the burglar answering the call. As you can see, our method of anti-jamming will in the worst possible case delay the alarm signal by ninety seconds but even more importantly will never allow for an audio connection between the burglar and the control panel.

All dialling products produced by Electronics Design and Manufacturing Pty Limited have incorporated this true anti-jamming feature as standard since 1985 and we do not consider it as an option but a must in any professional security system.

True anti-jamming can only be found in products produced by Electronics Design and Manufacturing Pty Limited and any other manufacturer can only offer second best due to our patent on this very unique and effective procedure.

Appendix B

Test Reports Only When Armed

The *Solution Ultima 844/862/880* control panel allows for test reports to be sent to the base station receiver to verify that the dialler functional. So what you might say, as most alarm diallers allow you to do this.

The one problem with this is that installations that report opening and closing reports will generally also send a test report each day. This call is unnecessary, as a successful opening and closing report means that the dialler is functioning correctly.

The *Solution Ultima 844/862/880* control panel allows you to save time and money by providing test reports only while the system is in the armed state.

Program "LOCATION 4" on page 231 with Option 1 (Send test reports only if the system is armed), and then set the test report time to be in the middle of the day. During Monday to Friday when the premises are generally open and the system disarmed a test report will not be sent. However, on the weekend, the premises will be closed and the system armed, so a test report will be sent at the programmed time thus verifying the operation of the dialler.

At first glance this may not seem to be a big deal but lets do a few sums and you will see just where savings can be made.

Let us assume that the customer wants, needs or has test reports programmed for once a day as well as opening and closing reports. This means that at least three phone calls will be made each week day and one call on Saturday and one call on Sunday.

By using the *Solution Ultima 844/862/880* control panel you will be able to eliminate five calls per week. This means that over one week you will save your customer \$1.25 and over one year you will save them \$65.00.

Not a bad saving, and remember these figures are for local calls only.

Turning the table slightly, a control room with lets say 1000 customers sending the above mentioned reports, can expect to receive some 884,000 phone calls (\$221,000 assuming local calls) just for reporting opening, closing and test reports over a 12 month period.

If you use the *Solution Ultima 844/862/880* control panel, you can effectively cut the calls to 624,000 per year (at a value of \$156,000 assuming local calls), a saving of \$65,000. If we now assume that for each call one line is printed on the logging printer, and that one page is filled per 60 calls. You will be able to save 4333 sheets of paper per year and at approximately \$45 per box this becomes a considerable saving.

As you can see using the *Solution Ultima 844/862/880* control panel will save you money, your customer money and will help conserve our natural resources, in fact, the only people who don't like this feature is Telecom.

Specifications

This section includes the following:

- *Warranty Statement*
- *Specifications*
- *Software Version Number*
- *Advice To Users*
- *New Zealand Telepermit Notes*

Warranty Statement

Electronics Design and Manufacturing Pty Limited warrants this product to be free from defects in material and workmanship for a period of three years from the date of manufacture as indicated by the date stamp and /or the serial number on the product.

Defective units returned by the purchaser at their own expense during this period will be repaired or replaced at the option of the manufacturer. The repair or replacement will be free of charge provided that the defects were not incurred during shipping or handling, or the damage was not due to causes beyond the control of Electronics Design and Manufacturing Pty Limited, such as lightning, excessive voltage, mechanical shock or damage arising out of abuse, alteration or improper application of the equipment.

Year 2000 Compliance

This notice is to confirm that all *Solution Ultima 844/862/880* control panels are not susceptible to, or can be corrupted by the "Year 2000 Millennium Bug".

To date, all *Solution* products that incorporate time keeping functions employ a rotating 100 year calendar. This means that the *Solution* products do not use the century in any time keeping algorithms, only the year within the century.

Specifications

<i>Temperature Range:</i>	0 – 45 Degrees Celsius
<i>Humidity</i>	10% - 95%
<i>Power Source:</i>	TF008 Plug Pack – 240 Volt / 18 Volt AC @ 1.3 Amp
<i>Stand-By Current:</i>	65 mA
<i>Current Draw In Alarm Condition:</i>	115 mA
<i>Current Draw With No Alarm and Codepad Fitted:</i>	105 mA
<i>Back-Up Battery:</i>	Ah / 12 Volt DC Rechargeable Sealed Lead Acid Battery
<i>Dimensions:</i>	306 mm x 262 mm x 84 mm (Packed In Carton)
<i>Weight:</i>	2.5 Kg
<i>Supplier Code:</i>	N771
<i>New Zealand Telepermit:</i>	PTC 211/98/083 – Solution Ultima 880 PTC 211/98/084 – Solution Ultima 862 PTC 211/98/085 – Solution Ultima 844

Software Version Number

LOCATION 999

1. 00

When using the Hand Held Programmer (CC814), you have the ability to display the software version number of the control panel. Refer to Command 999 - Display Panel Type Or Software Version Number on page 117 for more information.

Advice To Users

The Austel permit that has been issued for this product is subject to the following conditions.

- The *Solution Ultima 844/862/880* Control Panel may only be powered by an EDM TF008 Plug Pack (Approval Number Q92128).

New Zealand Telepermit Notes

- The grant of a telepermit for a device in no way indicates Telecom acceptance of responsibility for the correct operation of that device under all operating conditions.
- This equipment shall not be used in any manner that could constitute a nuisance to other Telecom customers.
- Immediately disconnect this equipment should it become physically damaged and arrange for its disposal or repair.
- The send level from this device is set at a fixed level and because of this there may be circumstances where the performance is less than optimal. Before reporting such occurrences as faults, please check the line with a standard telepermitted telephone and do not report a fault if the telephone performance is satisfactory.
- This device is equipped with pulse dialling while the Telecom standard is DTMF tone dialling. There is no guarantee that Telecom lines will always continue to support pulse dialling.

Use of dialling, when this equipment is connected to the same line as other equipment, may give rise to bell tinkle or noise and may also cause a false answer condition. Should such problems occur, the user should NOT contact the Telecom Faults Service.

- This equipment is set up to carry out test calls at pre-determined times. Such test calls will interrupt any other calls that may be set up on the line at the same time. The timing set for such test calls should be discussed with the installer.

The timing set for test calls from this equipment may be subject to drift. If this proves to be inconvenient and your calls are interrupted, then the problem of timing should be discussed with the equipment installer. The matter should NOT be reported as a fault to Telecom Faults Service.

- This equipment shall not be set up to make automatic calls to the Telecom 111 Emergency Service.

This equipment should not be used under any circumstances that may constitute a nuisance to other Telecom customers.

- In the event of any problem with this device, the systems battery, AC mains supply and telephone line should be disconnected. The user is to then arrange with the supplier of the device to make the necessary repairs.

Should the matter be reported to Telecom as a wiring fault and the fault be proven to be due to this product, a call-out charge will be incurred.

Solution Ultima 844
Programming Sheets

Location 000 – 015

Page 139

Primary Telephone Number For Receiver 1

0 0 0 0 0 0 0 0 0 0 0 0 0 0 0 0

Location 016 – 031

Page 139

Secondary Telephone Number For Receiver 1

0 0 0 0 0 0 0 0 0 0 0 0 0 0 0 0

Location 032

Page 140

Handshake Tone For Receiver 1

- 1 = HI-LO Handshake (Contact ID)
- 2 = 1400 Hz (TX @ 1900 Hz)
- 3 = 2300 Hz (Low Speed Sescoa)

- 4 = No Handshake Required
- 5 = Pager

1

Location 033

Page 141

Transmission Format For Receiver 1

- 1 = Contact ID
- 2 = 4 + 2 Express
- 3 = FSK 300 Baud
- 4 = Domestic

- 5 = Basic Pager
- 6 = Reserved
- 7 = Reserved
- 8 = Reserved

1

Location 034 – 039

Page 141

Subscriber ID Number For Receiver 1

0 0 0 0 0 0

Location 040 – 055

Page 142

Primary Telephone Number For Receiver 2

0 0 0 0 0 0 0 0 0 0 0 0 0 0 0 0

Location 056 – 071

Page 142

Secondary Telephone Number For Receiver 2

0 0 0 0 0 0 0 0 0 0 0 0 0 0 0 0

Location 072

Page 143

Handshake Tone For Receiver 2

- 1 = HI-LO Handshake (Contact ID)
- 2 = 1400 Hz (TX @ 1900 Hz)
- 3 = 2300 Hz (Low Speed Sescoa)

- 4 = No Handshake Required
- 5 = Pager

1

Location 073

Page 144

Transmission Format For Receiver 2

- 1 = Contact ID
- 2 = 4 + 2 Express
- 3 = FSK 300 Baud
- 4 = Domestic

- 5 = Basic Pager
- 6 = Reserved
- 7 = Reserved
- 8 = Reserved

1

Location 074 – 079

Page 144

Subscriber ID Number For Receiver 2

0 0 0 0 0 0

Location 080

Page 145

Dialling Format

- 1 = Australian DTMF (5 Digits/Second)
- 2 = Australian Decadic
- 3 = Alternate DTMF & Decadic (AUST)

- 4 = International DTMF
- 5 = Reversed Decadic
- 6 = Alternate DTMF & Reversed Decadic

1

Location 081 – 112

Page 145

Reserved

Location 113 – 142

Page 146

Telco Arming Sequence

0 0

Location 143 – 158

Page 147

Telco Disarming Sequence

0 0

Location 159 – 174

Page 147

Call Back Telephone Number

0 0

Location 175

Page 148

Ring Count

- 0 = Panel Will Not Answer
- 1 – 13 = No Of Rings Until Panel Answers

- 14 = Answering Machine Bypass 2
- 15 = Answering Machine Bypass 1

8

Location 176

Page 149

Telephone Line Fault Options

- 1 = Display FAULT Indicator When Telephone Line Fails
- 2 = Sound Alarm When System Is Armed
- 4 = Sound Alarm When System Is Disarmed
- 8 = Reserved

0

Location 177

Page 153

Dialler Options 1

- 1 = Dialler Reporting Functions Allowed
- 2 = Remote Arming Via The Telephone Allowed
- 4 = Answering Machine Bypass Only When Armed
- 8 = Use Bell 103 For FSK Format (Disabled – CCITT V21)

9

Location 178

Page 154

Dialler Options 2

- 1 = Open/Close Reports Only If Previous Alarm
- 2 = Open/Close Reports When In STAY Mode 1 and STAY Mode 2
- 4 = Delay Siren Until Transmission Complete
- 8 = Extend Time To Wait For Handshake From 30 Seconds To 55 Seconds

0

Location 179

Page 155

Dialler Options 3

- 1 = Set DTMF Dialling Pulses To 1 Digit/Second
- 2 = Lockout Telephone Line Fail Alarm **(New - Software Version 1.03)**
- 4 = Change Decadic Dialling To 60/40
- 8 = Reserved

0

Location 179 (New - Software Version 1.04)

Page 155

Dialler Options 3

- 1 = Set DTMF Dialling Pulses To 1 Digit/Second
- 2 = Lockout Telephone Line Fail Alarm **(New - Software Version 1.03)**
- 4 = Change Decadic Dialling To 60/40
- 8 = External Modem Module (CC811) Required For FSK (V1.09+)

2

Location 180

Page 124/156

Alarm Link Options

- 1 = Upload/Download Allowed
- 2 = Call Back Phone Number Required For Upload/Download
- 4 = Exit Upload/Download Connection On Alarm
- 8 = External Modem Module (CC811) Required For Upload/Download

3

Location 181 – 184

Page 158

Installer Code

1 2 3 4

Location 185 – 264

Page 159

User Codes

	Location 185 - 189	Location 190 - 194	
	User Code 1	User Code 2	
	2 5 8 0 10	15 15 15 15 2	
Location 195 - 199	Location 200 - 204	Location 205 - 209	
User Code 3	User Code 4	User Code 5	
15 15 15 15 2	15 15 15 15 2	15 15 15 15 2	
Location 210 - 214	Location 215 - 219	Location 220 - 224	
User Code 6	User Code 7	User Code 8	
15 15 15 15 2	15 15 15 15 2	0 15 15 15 3	
Location 225 - 229	Location 230 - 234	Location 235 - 239	
Radio Code 9	Radio Code 10	Radio Code 11	
15 15 15 15 2	15 15 15 15 2	15 15 15 15 2	
Location 240 - 244	Location 245 - 249	Location 250 - 254	
Radio Code 12	Radio Code 13	Radio Code 14	
15 15 15 15 2	15 15 15 15 2	15 15 15 15 2	
Location 255 - 259	Location 260 - 264		
Radio Code 15	Radio Code 16		
15 15 15 15 2	15 15 15 15 2		
	15 15 15 15	0	
	User Code	Priority	

Priority	Description	Priority	Description
0	Arm/Disarm	6	Arm/Disarm + Code To Isolate + Open/Close Report
1	Arm Only	8	Arm/Disarm + Master Code Functions
2	Arm/Disarm + Open/Close Report	10	Arm/Disarm + Master Code Functions + Open/Close Report
3	Arm Only + Close Report	12	Arm/Disarm + Master Code Functions + Code To Isolate
4	Arm/Disarm + Code To Isolate	14	Arm/Disarm + Master Code Functions + Code To Isolate + Open/Close Report

Table 161: User Code Priority Levels

Location 265

Page 164

Day Alarm Zones

1 = Zone 1
2 = Zone 2

4 = Zone 3
8 = Zone 4

0

Location 266

Page 166

EOL Resistor Value

0 = No End Of Line Resistor
1 = 1K
2 = 1K5
3 = 2K2
4 = 3K3
5 = 3K9
6 = 4K7
7 = 5K6
8 = 6K8

9 = 10K
10 = 12K
11 = 22K
12 = Reserved
13 = Reserved
14 = Split EOL (3K3/6K8) With Tamper (1K)
15 = Split EOL (3K3/6K8) – Six Burglary Zones and Two 24 Hour Zones

15

Location 267 – 322

Page 170

Zones

	<i>Zone 1</i> Location 267 - 273	<i>Zone 2</i> Location 274 - 280																					
	<table border="1" style="border-collapse: collapse; width: 100px; height: 20px;"><tr><td>2</td><td>0</td><td>0</td><td>1</td><td>14</td><td>1</td><td>1</td></tr></table>	2	0	0	1	14	1	1	<table border="1" style="border-collapse: collapse; width: 100px; height: 20px;"><tr><td>1</td><td>0</td><td>0</td><td>1</td><td>14</td><td>1</td><td>1</td></tr></table>	1	0	0	1	14	1	1							
2	0	0	1	14	1	1																	
1	0	0	1	14	1	1																	
<i>Zone 3</i> Location 281 - 287	<i>Zone 4</i> Location 288 - 294	<i>Zone 5</i> Location 295 – 301																					
<table border="1" style="border-collapse: collapse; width: 100px; height: 20px;"><tr><td>1</td><td>0</td><td>0</td><td>1</td><td>14</td><td>1</td><td>1</td></tr></table>	1	0	0	1	14	1	1	<table border="1" style="border-collapse: collapse; width: 100px; height: 20px;"><tr><td>1</td><td>0</td><td>0</td><td>1</td><td>14</td><td>1</td><td>1</td></tr></table>	1	0	0	1	14	1	1	<table border="1" style="border-collapse: collapse; width: 100px; height: 20px;"><tr><td>12</td><td>0</td><td>0</td><td>1</td><td>12</td><td>1</td><td>1</td></tr></table>	12	0	0	1	12	1	1
1	0	0	1	14	1	1																	
1	0	0	1	14	1	1																	
12	0	0	1	12	1	1																	
<i>Zone 6</i> Location 302 - 308	<i>Zone 7</i> Location 309 - 315	<i>Zone 8</i> Location 316 - 322																					
<table border="1" style="border-collapse: collapse; width: 100px; height: 20px;"><tr><td>12</td><td>0</td><td>0</td><td>1</td><td>12</td><td>1</td><td>1</td></tr></table>	12	0	0	1	12	1	1	<table border="1" style="border-collapse: collapse; width: 100px; height: 20px;"><tr><td>13</td><td>0</td><td>0</td><td>1</td><td>12</td><td>1</td><td>1</td></tr></table>	13	0	0	1	12	1	1	<table border="1" style="border-collapse: collapse; width: 100px; height: 20px;"><tr><td>9</td><td>0</td><td>0</td><td>1</td><td>12</td><td>1</td><td>1</td></tr></table>	9	0	0	1	12	1	1
12	0	0	1	12	1	1																	
13	0	0	1	12	1	1																	
9	0	0	1	12	1	1																	
<table border="1" style="border-collapse: collapse; width: 20px; height: 20px;"><tr><td> </td></tr></table>		<table border="1" style="border-collapse: collapse; width: 20px; height: 20px;"><tr><td> </td></tr></table>		<table border="1" style="border-collapse: collapse; width: 20px; height: 20px;"><tr><td> </td></tr></table>		<table border="1" style="border-collapse: collapse; width: 20px; height: 20px;"><tr><td> </td></tr></table>		<table border="1" style="border-collapse: collapse; width: 20px; height: 20px;"><tr><td> </td></tr></table>		<table border="1" style="border-collapse: collapse; width: 20px; height: 20px;"><tr><td> </td></tr></table>		<table border="1" style="border-collapse: collapse; width: 20px; height: 20px;"><tr><td> </td></tr></table>											
<i>Zone Type</i>	<i>Zone Pulse Count</i>	<i>Zone Pulse Count Time</i>	<i>Zone Option 1</i>	<i>Zone Option 2</i>	<i>Report Code</i>	<i>Dialler Options</i>																	

Zone Types

There are fifteen different zone types to choose from. Each zone contains eight locations. Zones 1 to 4 are fully programmable whereas zones 5 to 8 may only be programmed to any 24 hour zone type.

Zone Type	Description	Zone Type	Description
0	Instant	8	24 Hour Hold-Up
1	Handover	9	24 Hour Tamper
2	Delay-1	10	Reserved
3	Delay-2	11	Keyswitch
4	Reserved	12	24 Hour Burglary
5	Reserved	13	24 Hour Fire
6	24 Hour Medical	14	Chime Only
7	24 Hour Panic	15	Zone Not Used

Table 162: Available Zone Types

Zone Pulse Count Settings

The pulse count settings for each zone can be programmed between 0 - 15.

Zone Pulse Count Time

Zone pulse count time is the time frame or period over which the number of pulses must register.

<i>20 ms Loop Response Time Zone Pulse Count Time</i>		<i>150 ms Loop Response Time Zone Pulse Count Time</i>	
0	0.5 Second	8	20 Seconds
1	1 Second	9	30 Seconds
2	2 Seconds	10	40 Seconds
3	3 Seconds	11	50 Seconds
4	4 Seconds	12	60 Seconds
5	5 Seconds	13	90 Seconds
6	10 Seconds	14	120 Seconds
7	15 Seconds	15	200 Seconds

Table 163: Zone Pulse Count Time Options

Zone Options 1

<i>Option</i>	<i>Description</i>
1	Lockout Siren/Lockout Dialler
2	Delay Alarm Reporting
4	Silent Alarm
8	Sensor Watch

Table 164: Zone Options 1

Zone Options 2

<i>Option</i>	<i>Description</i>
1	Isolated In STAY Mode 1
2	Zone Isolation Allowed
4	Forced Arming Allowed
8	Enable Zone Restore Report

Table 165: Zone Options 2

Zone Dialler Options

<i>Option</i>	<i>Description</i>
0	No Report Required
1	Receiver 1
2	Receiver 2
4	Receiver 1 + 2
8	Receiver 2 Only When Receiver 1 Fails

Table 166: Zone Dialler Options

Zone Descriptions

Use this table as a reference to indicate what each zone is connected to.

<i>Zone</i>	<i>Description</i>	<i>Zone</i>	<i>Description</i>
1		5	
2		6	
3		7	
4		8	

Table 167: Zone Descriptions

Location 323 <i>Swinger Shutdown Count For Siren</i>			Page 181	3
Location 324 <i>Swinger Shutdown Count For Dialler</i>			Page 182	6
Location 325 – 326 <i>Zone Status - Zone Tamper Report</i>	Location 325 Location 326	Zone Tamper Report Zone Tamper Restore Report	Page 184	0 0
Location 327 – 328 <i>Zone Status - Walk Test Report</i>	Location 327 Location 328	Walk Test Enable Report Walk Test Disable Report	Page 184	0 0
Location 329 – 330 <i>Zone Status - Bypass Reports</i>	Location 329 Location 330	Zone Bypass Report Zone Bypass Restore Report	Page 185	9 8
Location 331 – 332 <i>Zone Status - Trouble Reports</i>	Location 331 Location 332	Zone Trouble Report Zone Trouble Restore Report	Page 185	2 3
Location 333 – 334 <i>Zone Status - Sensor Watch Reports</i>	Location 333 Location 334	Sensor Watch Report Sensor Watch Restore Report	Page 186	4 5
Location 335 <i>Zone Status - Alarm Restore Code</i>			Page 186	14
Location 336 <i>Zone Status Reporting Options</i>		0 = No Report Required 1 = Receiver 1 2 = Receiver 2 4 = Receiver 1 + 2 8 = Receiver 2 Only When Receiver 1 Fails	Page 186	1
Location 337 <i>RF Supervision Time</i>	Location 337	Increments Of 6 Hours (0 – 90 Hours)	Page 187	0
Location 338 – 339 <i>RF Low Battery Report</i>	Location 338 Location 339	RF Low Battery Report RF Low Battery Restore Report	Page 187	6 8
Location 340 – 341 <i>RF Receiver Trouble Report</i>	Location 340 Location 341	RF Receiver Trouble Report (Tens Digit) RF Receiver Trouble Report (Units Digit)	Page 188	7 9
Location 342 – 343 <i>RF Receiver Trouble Restore Report</i>	Location 342 Location 343	RF Receiver Trouble Restore Report (Tens Digit) RF Receiver Trouble Restore Report (Units Digit)	Page 188	7 11
Location 344 <i>RF Dialler Options</i>		0 = No Report Required 1 = Receiver 1 2 = Receiver 2 4 = Receiver 1 + 2 8 = Receiver 2 Only When Receiver 1 Fails	Page 188	1
Location 345 – 346 <i>Open/Close Reports</i>	Location 345 Location 346	Opening Report Closing Report	Page 189	11 12
Location 347 <i>Open/Close Reporting Options</i>		0 = No Report Required 1 = Receiver 1 2 = Receiver 2 4 = Receiver 1 + 2 8 = Receiver 2 Only When Receiver 1 Fails	Page 189	1
Location 348 <i>Codepad Duress Report</i>			Page 190	6
Location 349 – 350 <i>Codepad Panic Report</i>			Page 190	7 15
Location 351 – 352 <i>Codepad Fire Report</i>			Page 191	7 14

Location 353 – 354
Codepad Medical Report

Page 191

7	13
---	----

Location 355
Codepad Reporting Options

- 0 = No Report Required
- 1 = Receiver 1
- 2 = Receiver 2
- 4 = Receiver 1 + 2
- 8 = Receiver 2 Only When Receiver 1 Fails

Page 192

1

Location 356 – 357
System Status – Fuse Fail Report

Page 192

10	3
----	---

Location 358 – 359
System Status – Fuse Fail Restore Report

Page 192

10	8
----	---

Location 360 – 361
System Status – AC Fail Report

Page 193

10	2
----	---

Location 362 – 363
System Status - AC Fail Restore Report

Page 193

10	7
----	---

Location 364 – 365
System Status - Low Battery Report

Page 194

10	1
----	---

Location 366 – 367
System Status - Low Battery Restore Report

Page 194

10	6
----	---

Location 368 – 370
System Status – Access Denied

- Location 368 Code Retries
- Location 369 Reporting Code – Tens Digit
- Location 370 Reporting Code – Units Digit

Page 195

6	7	12
---	---	----

Location 371
System Status Reporting Options

- 0 = No Report Required
- 1 = Receiver 1
- 2 = Receiver 2
- 4 = Receiver 1 + 2
- 8 = Receiver 2 Only When Receiver 1 Fails

Page 196

1

Location 372 – 378
Test Reporting Time

- Location 372 Actual Hour Of The Day (Tens Digit)
- Location 373 Actual Hour Of The Day (Units Digit)
- Location 374 Actual Minute Of The Day (Tens Digit)
- Location 375 Actual Minute Of The Day (Units Digit)
- Location 376 Test Report Code (Tens Digit)
- Location 377 Test Report Code (Units Digit)
- Location 378 Repeat Interval In Days

0	0	0	0	7	1	0
---	---	---	---	---	---	---

Page 197

Location 379
Test Reporting Dialler Options

- 0 = No Report Required
- 1 = Receiver 1
- 2 = Receiver 2
- 4 = Receiver 1 + 2
- 8 = Receiver 2 Only When Receiver 1 Fails

Page 197

1

Location 380 – 409
Output Configurations

Page 200

Output 1

1	14	0	0	0	0
---	----	---	---	---	---

Location 380 - 385

Default For Horn Speaker

Output 2

2	7	10	2	1	5
---	---	----	---	---	---

Location 386 - 391

Default For Fire Alarm Verification

Strobe

2	0	6	4	0	8
---	---	---	---	---	---

Location 392 – 397

Default For Strobe (Reset In 8 Hrs)

Relay

1	15	1	0	0	0
---	----	---	---	---	---

Location 398 – 403

Default For Sirens Running

Codepad

0	13	2	1	0	1
---	----	---	---	---	---

Location 404 – 409

Default For Entry/Exit Warning + Day Alarm



Event Type



Polarity



Time Base



Time Multiplier

Location 410 – 411 <i>Entry Timer 1</i>	Location 410 Location 411	Increments Of 1 Second (0 - 15 Sec's) Increments Of 16 Seconds (0 - 240 Sec's)	Page 216 <table border="1"><tr><td>4</td><td>1</td></tr></table>	4	1		
4	1						
Location 412 – 413 <i>Entry Timer 2</i>	Location 412 Location 413	Increments Of 1 Second (0 - 15 Sec's) Increments Of 16 Seconds (0 - 240 Sec's)	Page 216 <table border="1"><tr><td>8</td><td>2</td></tr></table>	8	2		
8	2						
Location 414 – 415 <i>Exit Time</i>	Location 414 Location 415	Increments Of 1 Second (0 - 15 Sec's) Increments Of 16 Seconds (0 - 240 Sec's)	Page 217 <table border="1"><tr><td>12</td><td>3</td></tr></table>	12	3		
12	3						
Location 416 – 417 <i>Entry Guard Time For STAY Mode</i>	Location 416 Location 417	Increments Of 1 Second (0 - 15 Sec's) Increments Of 16 Seconds (0 - 240 Sec's)	Page 217 <table border="1"><tr><td>0</td><td>0</td></tr></table>	0	0		
0	0						
Location 418 – 419 <i>Delay Alarm Reporting Time</i>	Location 418 Location 419	Increments Of 1 Second (0 - 15 Sec's) Increments Of 16 Seconds (0 - 240 Sec's)	Page 217 <table border="1"><tr><td>0</td><td>0</td></tr></table>	0	0		
0	0						
Location 420 - 421 <i>Sensor Watch Time</i>	Location 420 Location 421	Increments Of Days (Tens Digit) Increments Of Days (Units Digit)	Page 218 <table border="1"><tr><td>0</td><td>0</td></tr></table>	0	0		
0	0						
Location 422 <i>Codepad Lockout Time</i>	Location 422	Increments Of 10 Seconds	Page 218 <table border="1"><tr><td>0</td></tr></table>	0			
0							
Location 423 <i>Siren Run Time</i>	Location 423	Increments Of 1 Minute (0 – 15 Min's)	Page 219 <table border="1"><tr><td>5</td></tr></table>	5			
5							
Location 424 <i>Siren Sound Rate (Slow <-Sound-> Fast)</i>			Page 219 <table border="1"><tr><td>7</td></tr></table>	7			
7							
Location 425 <i>Auto Arming Pre-Alert Time</i>	Location 425	Increments Of 5 Minutes	Page 220 <table border="1"><tr><td>1</td></tr></table>	1			
1							
Location 426 – 429 <i>Auto Arming Time</i>	Location 426 Location 427 Location 428 Location 429	Hour Of The Day (Tens Digit) Hour Of The Day (Units Digit) Minute Of The Day (Tens Digit) Minute Of The Day (Units Digit)	Page 220 <table border="1"><tr><td>0</td><td>0</td><td>0</td><td>0</td></tr></table>	0	0	0	0
0	0	0	0				
Location 430 - 433 <i>Auto Disarming Time</i>	Location 430 Location 431 Location 432 Location 433	Hour Of The Day (Tens Digit) Hour Of The Day (Units Digit) Minute Of The Day (Tens Digit) Minute Of The Day (Units Digit)	Page 221 <table border="1"><tr><td>0</td><td>0</td><td>0</td><td>0</td></tr></table>	0	0	0	0
0	0	0	0				
Location 434 <i>Kiss-Off Wait Time</i>	Location 434	Increments Of 500 ms (500 ms – 8 Sec's)	Page 221 <table border="1"><tr><td>3</td></tr></table>	3			
3							
Location 435 <i>Speaker Beep Volume</i>	Location 435	0 = No Beeps / 15 = Loudest Beeps	Page 221 <table border="1"><tr><td>13</td></tr></table>	13			
13							
Location 436 <i>System Options 1</i>		1 = EDM Smart Lockout Allowed 2 = Horn Speaker Monitor 4 = Strobe Indications For Radio Arm/Disarm 8 = Assign Button 4 On Transmitter To Operate STAY Mode 1	Page 227 <table border="1"><tr><td>1</td></tr></table>	1			
1							
Location 437 <i>System Options 2</i>		1 = Codepad Panic To Be Silent 2 = Codepad Fire To Be Silent 4 = Codepad Medical To Be Silent 8 = Access Denied To Be Silent	Page 228 <table border="1"><tr><td>0</td></tr></table>	0			
0							
Location 438 <i>System Options 3</i>		1 = AC Fail After 1 Hour (Disabled = After 2 Minutes) 2 = Ignore AC Fail 4 = Pulse Count Handover Allowed 8 = Handover Delay To Be Sequential	Page 229 <table border="1"><tr><td>8</td></tr></table>	8			
8							
Location 439 <i>System Options 4</i>		1 = Panel To Power Up Disarmed (If Power Reset) 2 = Arm/Disarm Tracking On Power Up 4 = Internal Crystal To Keep Time 8 = Keyswitch Interface, Night Arm Station Or RE005 Installed	Page 230 <table border="1"><tr><td>0</td></tr></table>	0			
0							

Location 440 <i>Consumer Options 1</i>	1 = Test Reports Only When Armed 2 = Test Report After Siren Reset 4 = Auto Arm In STAY Mode 1 8 = STAY Indicator To Display Day Alarm Status	Page 231	0
Location 441 <i>Consumer Options 2</i>	1 = Codepad Display Extinguish After 60 Seconds 2 = Single Button Arming Allowed (AWAY Mode, STAY Mode 1 & 2) 4 = Single Button Disarming Allowed (STAY Mode 1 & 2) 8 = Alarm Memory Reset On Disarm	Page 232	2
Location 442 <i>Consumer Options 3</i>	1 = Codepad Fault Alarm Beeps Allowed 2 = Use Digit 3 For Codepad Duress Instead Of Digit 9 4 = Alarms Activate Siren & Strobe In STAY Mode 1 and 2 8 = Zone Tamper Alarms To Be Silent	Page 233	5
Location 443 <i>Radio Input Options</i>	1 = DS 304 MHz Receiver (RF3212) 2 = Latching Keypad Input 3 = Momentary Keypad Input 4 = Reserved	Page 234	0
Location 478 – 525 <i>Domestic Telephone Numbers</i>		Page 127	
Location 526 <i>Reserved</i>			0
Location 527 <i>RF Options</i>	1 = Sound Siren On RF Receiver Fail 2 = Sound Siren On RF Receiver Tamper / Jamming 4 = Unseal Zone That Fails Supervision (Only If Supervision Enabled) 8 = Enable RF Jamming Monitoring	Page 250	0
Location 528 – 535 <i>RF Device Mapping (Devices 1 – 8)</i>		Page 250	1 2 3 4 5 6 7 8
Location 536 – 543 <i>RF Device Mapping (Devices 9 – 16)</i>		Page 250	0 0 0 0 0 0 0 0
Location 801 – 808 <i>RF Device Signal Strength (Devices 1 – 8 Read Only)</i>		Page 251	0 0 0 0 0 0 0 0
Location 809 – 816 <i>RF Device Signal Strength (Devices 9 – 16 Read Only)</i>		Page 251	0 0 0 0 0 0 0 0
Location 900 <i>Disable Factory Default</i>	0 = Defaulting Enabled 15 = Defaulting Disabled	Page 118	0
Location 901 – 904 <i>System Time</i>	Location 901 Hour Of The Day (Tens Digit) Location 902 Hour Of The Day (Units Digit) Location 903 Minute Of The Day (Tens Digit) Location 904 Minute Of The Day (Units Digit)	Page 222	0 0 0 0
Location 905 – 910 <i>System Date</i>	Location 905 Day Of The Month (Tens Digit) Location 906 Day Of The Month (Units Digit) Location 907 Month Of The Year (Tens Digit) Location 908 Month Of The Year (Units Digit) Location 909 Year (Tens Digit) Location 910 Year (Units Digit)	Page 223	0 1 0 1 0 1

Solution Ultima 862
Programming Sheets

Location 000 – 015

Page 139

Primary Telephone Number For Receiver 1

0 0 0 0 0 0 0 0 0 0 0 0 0 0 0 0

Location 016 – 031

Page 139

Secondary Telephone Number For Receiver 1

0 0 0 0 0 0 0 0 0 0 0 0 0 0 0 0

Location 032

Page 140

Handshake Tone For Receiver 1

- 1 = HI-LO Handshake (Contact ID)
- 2 = 1400 Hz (TX @ 1900 Hz)
- 3 = 2300 Hz (Low Speed Sescoa)

- 4 = No Handshake Required
- 5 = Pager

1

Location 033

Page 141

Transmission Format For Receiver 1

- 1 = Contact ID
- 2 = 4 + 2 Express
- 3 = FSK 300 Baud
- 4 = Domestic

- 5 = Basic Pager
- 6 = Reserved
- 7 = Reserved
- 8 = Reserved

1

Location 034 – 039

Page 141

Subscriber ID Number For Receiver 1

0 0 0 0 0 0

Location 040 – 055

Page 142

Primary Telephone Number For Receiver 2

0 0 0 0 0 0 0 0 0 0 0 0 0 0 0 0

Location 056 – 071

Page 142

Secondary Telephone Number For Receiver 2

0 0 0 0 0 0 0 0 0 0 0 0 0 0 0 0

Location 072

Page 143

Handshake Tone For Receiver 2

- 1 = HI-LO Handshake (Contact ID)
- 2 = 1400 Hz (TX @ 1900 Hz)
- 3 = 2300 Hz (Low Speed Sescoa)

- 4 = No Handshake Required
- 5 = Pager

1

Location 073

Page 144

Transmission Format For Receiver 2

- 1 = Contact ID
- 2 = 4 + 2 Express
- 3 = FSK 300 Baud
- 4 = Domestic

- 5 = Basic Pager
- 6 = Reserved
- 7 = Reserved
- 8 = Reserved

1

Location 074 – 079

Page 144

Subscriber ID Number For Receiver 2

0 0 0 0 0 0

Location 080

Page 145

Dialling Format

- 1 = Australian DTMF (5 Digits/Second)
- 2 = Australian Decadic
- 3 = Alternate DTMF & Decadic (AUST)

- 4 = International DTMF
- 5 = Reversed Decadic
- 6 = Alternate DTMF & Reversed Decadic

1

Location 081 – 112

Page 145

Reserved

Location 113 – 142

Page 146

Telco Arming Sequence

0 0

Location 143 – 158

Page 147

Telco Disarming Sequence

0 0 0 0 0 0 0 0 0 0 0 0 0 0 0 0 0 0

Location 159 – 174

Page 147

Call Back Telephone Number

0 0 0 0 0 0 0 0 0 0 0 0 0 0 0 0

Location 175

Page 148

Ring Count

- 0 = Panel Will Not Answer
- 1 – 13 = No Of Rings Until Panel Answers

- 14 = Answering Machine Bypass 2
- 15 = Answering Machine Bypass 1

8

Location 176

Page 149

Telephone Line Fault Options

- 1 = Display FAULT Indicator When Telephone Line Fails
- 2 = Sound Alarm When System Is Armed
- 4 = Sound Alarm When System Is Disarmed
- 8 = Reserved

0

Location 177 Page 153
Dialler Options 1
 1 = Dialler Reporting Functions Allowed
 2 = Remote Arming Via The Telephone Allowed
 4 = Answering Machine Bypass Only When Armed
 8 = Use Bell 103 For FSK Format (Disabled – CCITT V21) 9

Location 178 Page 154
Dialler Options 2
 1 = Open/Close Reports Only If A Previous Alarm Has Occurred
 2 = Open/Close Reports When In STAY Mode 1 and STAY Mode 2
 4 = Delay Siren Until Transmission Complete
 8 = Extend Time To Wait For Handshake From 30 Seconds To 55 Seconds 0

Location 179 Page 155
Dialler Options 3
 1 = Set DTMF Dialling Pulses To 1 Digit/Second
 2 = Lockout Telephone Line Fail Alarm **(New - Software Version 1.03)**
 4 = Change Decadic Dialling To 60/40
 8 = Reserved 0

Location 179 **(New - Software Version 1.04)** Page 155
Dialler Options 3
 1 = Set DTMF Dialling Pulses To 1 Digit/Second
 2 = Lockout Telephone Line Fail Alarm **(New - Software Version 1.03)**
 4 = Change Decadic Dialling To 60/40
 8 = External Modem Module (CC811) Required For FSK (V1.09+) 2

Location 180 Page 124/156
Alarm Link Options
 1 = Upload/Download Allowed
 2 = Call Back Phone Number Required For Upload/Download
 4 = Exit Upload/Download Connection On Alarm
 8 = External Modem Module (CC811) Required For Upload/Download 3

Location 181 – 184 Page 158
Installer Code
1 2 3 4

Location 185 – 264 Page 159
User Codes

	Location 185 - 189	Location 190 - 194	
	User Code 1 2 5 8 0 10	User Code 2 15 15 15 15 2	
Location 195 - 199	Location 200 - 204	Location 205 - 209	
User Code 3 15 15 15 15 2	User Code 4 15 15 15 15 2	User Code 5 15 15 15 15 2	
Location 210 - 214	Location 215 - 219	Location 220 - 224	
User Code 6 15 15 15 15 2	User Code 7 15 15 15 15 2	User Code 8 0 15 15 15 3	
Location 225 - 229	Location 230 - 234	Location 235 - 239	
Radio Code 9 15 15 15 15 2	Radio Code 10 15 15 15 15 2	Radio Code 11 15 15 15 15 2	
Location 240 - 244	Location 245 - 249	Location 250 - 254	
Radio Code 12 15 15 15 15 2	Radio Code 13 15 15 15 15 2	Radio Code 14 15 15 15 15 2	
Location 255 - 259	Location 260 - 264		
Radio Code 15 15 15 15 15 2	Radio Code 16 15 15 15 15 2		
	15 15 15 15	0	
	User Code	Priority	

Priority	Description	Priority	Description
0	Arm/Disarm	6	Arm/Disarm + Code To Isolate + Open/Close Report
1	Arm Only	8	Arm/Disarm + Master Code Functions
2	Arm/Disarm + Open/Close Report	10	Arm/Disarm + Master Code Functions + Open/Close Report
3	Arm Only + Close Report	12	Arm/Disarm + Master Code Functions + Code To Isolate
4	Arm/Disarm + Code To Isolate	14	Arm/Disarm + Master Code Functions + Code To Isolate + Open/Close Report

Table 168: User Code Priority Levels

Location 265

Page 164

Day Alarm Zones

1 = Zone 1
2 = Zone 2

4 = Zone 3
8 = Zone 4

0

Location 266

Page 166

EOL Resistor Value

0 = No End Of Line Resistor
1 = 1K
2 = 1K5
3 = 2K2
4 = 3K3
5 = 3K9
6 = 4K7
7 = 5K6
8 = 6K8

9 = 10K
10 = 12K
11 = 22K
12 = Reserved
13 = Reserved
14 = Split EOL (3K3/6K8) With Tamper (1K)
15 = Split EOL (3K3/6K8) – Six Burglary Zones and Two 24 Hour Zones

15

Location 267 – 322

Page 170

Zones

	<i>Zone 1</i> Location 267 - 273	<i>Zone 2</i> Location 274 - 280																					
	<table border="1" style="border-collapse: collapse; width: 100px; height: 20px;"><tr><td>2</td><td>0</td><td>0</td><td>1</td><td>14</td><td>1</td><td>1</td></tr></table>	2	0	0	1	14	1	1	<table border="1" style="border-collapse: collapse; width: 100px; height: 20px;"><tr><td>1</td><td>0</td><td>0</td><td>1</td><td>14</td><td>1</td><td>1</td></tr></table>	1	0	0	1	14	1	1							
2	0	0	1	14	1	1																	
1	0	0	1	14	1	1																	
<i>Zone 3</i> Location 281 - 287	<i>Zone 4</i> Location 288 - 294	<i>Zone 5</i> Location 295 – 301																					
<table border="1" style="border-collapse: collapse; width: 100px; height: 20px;"><tr><td>1</td><td>0</td><td>0</td><td>1</td><td>14</td><td>1</td><td>1</td></tr></table>	1	0	0	1	14	1	1	<table border="1" style="border-collapse: collapse; width: 100px; height: 20px;"><tr><td>1</td><td>0</td><td>0</td><td>1</td><td>14</td><td>1</td><td>1</td></tr></table>	1	0	0	1	14	1	1	<table border="1" style="border-collapse: collapse; width: 100px; height: 20px;"><tr><td>0</td><td>0</td><td>0</td><td>1</td><td>14</td><td>1</td><td>1</td></tr></table>	0	0	0	1	14	1	1
1	0	0	1	14	1	1																	
1	0	0	1	14	1	1																	
0	0	0	1	14	1	1																	
<i>Zone 6</i> Location 302 - 308	<i>Zone 7</i> Location 309 - 315	<i>Zone 8</i> Location 316 - 322																					
<table border="1" style="border-collapse: collapse; width: 100px; height: 20px;"><tr><td>0</td><td>0</td><td>0</td><td>1</td><td>14</td><td>1</td><td>1</td></tr></table>	0	0	0	1	14	1	1	<table border="1" style="border-collapse: collapse; width: 100px; height: 20px;"><tr><td>13</td><td>0</td><td>0</td><td>1</td><td>12</td><td>1</td><td>1</td></tr></table>	13	0	0	1	12	1	1	<table border="1" style="border-collapse: collapse; width: 100px; height: 20px;"><tr><td>9</td><td>0</td><td>0</td><td>1</td><td>12</td><td>1</td><td>1</td></tr></table>	9	0	0	1	12	1	1
0	0	0	1	14	1	1																	
13	0	0	1	12	1	1																	
9	0	0	1	12	1	1																	
<table border="1" style="border-collapse: collapse; width: 20px; height: 20px;"><tr><td> </td></tr></table>		<table border="1" style="border-collapse: collapse; width: 20px; height: 20px;"><tr><td> </td></tr></table>		<table border="1" style="border-collapse: collapse; width: 20px; height: 20px;"><tr><td> </td></tr></table>		<table border="1" style="border-collapse: collapse; width: 20px; height: 20px;"><tr><td> </td></tr></table>		<table border="1" style="border-collapse: collapse; width: 20px; height: 20px;"><tr><td> </td></tr></table>		<table border="1" style="border-collapse: collapse; width: 20px; height: 20px;"><tr><td> </td></tr></table>		<table border="1" style="border-collapse: collapse; width: 20px; height: 20px;"><tr><td> </td></tr></table>											
<i>Zone Type</i>	<i>Zone Pulse Count</i>	<i>Zone Pulse Count Time</i>	<i>Zone Option 1</i>	<i>Zone Option 2</i>	<i>Report Code</i>	<i>Dialler Options</i>																	

Zone Types

There are fifteen different zone types to choose from. Each zone contains eight locations. Zones 1 to 6 are fully programmable whereas zones 7 and 8 may only be programmed to any 24 hour zone type.

Zone Type	Description	Zone Type	Description
0	Instant	8	24 Hour Hold-Up
1	Handover	9	24 Hour Tamper
2	Delay-1	10	Reserved
3	Delay-2	11	Keyswitch
4	Reserved	12	24 Hour Burglary
5	Reserved	13	24 Hour Fire
6	24 Hour Medical	14	Chime Only
7	24 Hour Panic	15	Zone Not Used

Table 169: Available Zone Types

Zone Pulse Count Settings

The pulse count settings for each zone can be programmed between 0 - 15.

Zone Pulse Count Time

Zone pulse count time is the time frame or period over which the number of pulses must register.

<i>20 ms Loop Response Time Zone Pulse Count Time</i>		<i>150 ms Loop Response Time Zone Pulse Count Time</i>	
0	0.5 Second	8	20 Seconds
1	1 Second	9	30 Seconds
2	2 Seconds	10	40 Seconds
3	3 Seconds	11	50 Seconds
4	4 Seconds	12	60 Seconds
5	5 Seconds	13	90 Seconds
6	10 Seconds	14	120 Seconds
7	15 Seconds	15	200 Seconds

Table 170: Zone Pulse Count Time Options

Zone Options 1

<i>Option</i>	<i>Description</i>
1	Lockout Siren/Lockout Dialler
2	Delay Alarm Reporting
4	Silent Alarm
8	Sensor Watch

Table 171: Zone Options 1

Zone Options 2

<i>Option</i>	<i>Description</i>
1	Isolated In STAY Mode 1
2	Zone Isolation Allowed
4	Forced Arming Allowed
8	Enable Zone Restore Report

Table 172: Zone Options 2

Zone Dialler Options

<i>Option</i>	<i>Description</i>
0	No Report Required
1	Receiver 1
2	Receiver 2
4	Receiver 1 + 2
8	Receiver 2 Only When Receiver 1 Fails

Table 173: Zone Dialler Options

Zone Descriptions

Use this table as a reference to indicate what each zone is connected to.

<i>Zone</i>	<i>Description</i>	<i>Zone</i>	<i>Description</i>
1		5	
2		6	
3		7	
4		8	

Table 174: Zone Descriptions

Location 323 <i>Swinger Shutdown Count For Siren</i>			Page 181	3
Location 324 <i>Swinger Shutdown Count For Dialler</i>			Page 182	6
Location 325 – 326 <i>Zone Status - Zone Tamper Report</i>	Location 325 Location 326	Zone Tamper Report Zone Tamper Restore Report	Page 184	0 0
Location 327 – 328 <i>Zone Status - Walk Test Report</i>	Location 327 Location 328	Walk Test Enable Report Walk Test Disable Report	Page 184	0 0
Location 329 – 330 <i>Zone Status - Bypass Reports</i>	Location 329 Location 330	Zone Bypass Report Zone Bypass Restore Report	Page 185	9 8
Location 331 – 332 <i>Zone Status - Trouble Reports</i>	Location 331 Location 332	Zone Trouble Report Zone Trouble Restore Report	Page 185	2 3
Location 333 – 334 <i>Zone Status - Sensor Watch Reports</i>	Location 333 Location 334	Sensor Watch Report Sensor Watch Restore Report	Page 186	4 5
Location 335 <i>Zone Status - Alarm Restore Code</i>			Page 186	14
Location 336 <i>Zone Status Reporting Options</i>		0 = No Report Required 1 = Receiver 1 2 = Receiver 2 4 = Receiver 1 + 2 8 = Receiver 2 Only When Receiver 1 Fails	Page 186	1
Location 337 <i>RF Supervision Time</i>	Location 337	Increments Of 6 Hours (0 – 90 Hours)	Page 187	0
Location 338 – 339 <i>RF Low Battery Report</i>	Location 338 Location 339	RF Low Battery Report RF Low Battery Restore Report	Page 187	6 8
Location 340 – 341 <i>RF Receiver Trouble Report</i>	Location 340 Location 341	RF Receiver Trouble Report (Tens Digit) RF Receiver Trouble Report (Units Digit)	Page 188	7 12
Location 342 – 343 <i>RF Receiver Trouble Restore Report</i>	Location 342 Location 343	RF Receiver Trouble Restore Report (Tens Digit) RF Receiver Trouble Restore Report (Units Digit)	Page 188	7 11
Location 344 <i>RF Dialler Options</i>		0 = No Report Required 1 = Receiver 1 2 = Receiver 2 4 = Receiver 1 + 2 8 = Receiver 2 Only When Receiver 1 Fails	Page 188	1
Location 345 – 346 <i>Open/Close Reports</i>	Location 345 Location 346	Opening Report Closing Report	Page 189	11 12
Location 347 <i>Open/Close Reporting Options</i>		0 = No Report Required 1 = Receiver 1 2 = Receiver 2 4 = Receiver 1 + 2 8 = Receiver 2 Only When Receiver 1 Fails	Page 189	1
Location 348 <i>Codepad Duress Report</i>			Page 190	6
Location 349 – 350 <i>Codepad Panic Report</i>			Page 190	7 15
Location 351 – 352 <i>Codepad Fire Report</i>			Page 191	7 14

Location 353 – 354
Codepad Medical Report

Page 191
7 13

Location 355
Codepad Reporting Options

- 0 = No Report Required
- 1 = Receiver 1
- 2 = Receiver 2
- 4 = Receiver 1 + 2
- 8 = Receiver 2 Only When Receiver 1 Fails

Page 192
1

Location 356 – 357
System Status – Fuse Fail Report

Page 192
10 3

Location 358 – 359
System Status – Fuse Fail Restore Report

Page 192
10 8

Location 360 – 361
System Status – AC Fail Report

Page 193
10 2

Location 362 – 363
System Status - AC Fail Restore Report

Page 193
10 7

Location 364 – 365
System Status - Low Battery Report

Page 194
10 1

Location 366 – 367
System Status - Low Battery Restore Report

Page 194
10 6

Location 368 – 370
System Status – Access Denied

- Location 368 Code Retries
- Location 369 Reporting Code – Tens Digit
- Location 370 Reporting Code – Units Digit

Page 195
6 7 12

Location 371
System Status Reporting Options

- 0 = No Report Required
- 1 = Receiver 1
- 2 = Receiver 2
- 4 = Receiver 1 + 2
- 8 = Receiver 2 Only When Receiver 1 Fails

Page 196
1

Location 372 – 378
Test Reporting Time

- Location 372 Actual Hour Of The Day (Tens Digit)
- Location 373 Actual Hour Of The Day (Units Digit)
- Location 374 Actual Minute Of The Day (Tens Digit)
- Location 375 Actual Minute Of The Day (Units Digit)
- Location 376 Test Report Code (Tens Digit)
- Location 377 Test Report Code (Units Digit)
- Location 378 Repeat Interval In Days

0 0 0 0 7 1 0

Page 197

Location 379
Test Reporting Dialler Options

- 0 = No Report Required
- 1 = Receiver 1
- 2 = Receiver 2
- 4 = Receiver 1 + 2
- 8 = Receiver 2 Only When Receiver 1 Fails

Page 197
1

Location 380 – 409
Output Configurations

Page 200

Output 1

1	14	0	0	0	0
---	----	---	---	---	---

Location 380 - 385

Default For
Horn Speaker

Output 2

2	7	10	2	1	5
---	---	----	---	---	---

Location 386 - 391

Default For
Fire Alarm Verification

Strobe

2	0	6	4	0	8
---	---	---	---	---	---

Location 392 – 397

Default For Strobe
(Reset In 8 Hrs)

Relay

1	15	1	0	0	0
---	----	---	---	---	---

Location 398 – 403

Default For
Sirens Running

Codepad

0	13	2	1	0	1
---	----	---	---	---	---

Location 404 – 409

Default For Entry/Exit
Warning + Day Alarm



Event Type



Polarity



Time Base



Time Multiplier

Location 410 – 411 <i>Entry Timer 1</i>	Location 410 Location 411	Increments Of 1 Second (0 - 15 Sec's) Increments Of 16 Seconds (0 - 240 Sec's)	Page 216 <table border="1"><tr><td>4</td><td>1</td></tr></table>	4	1		
4	1						
Location 412 – 413 <i>Entry Timer 2</i>	Location 412 Location 413	Increments Of 1 Second (0 - 15 Sec's) Increments Of 16 Seconds (0 - 240 Sec's)	Page 216 <table border="1"><tr><td>8</td><td>2</td></tr></table>	8	2		
8	2						
Location 414 – 415 <i>Exit Time</i>	Location 414 Location 415	Increments Of 1 Second (0 - 15 Sec's) Increments Of 16 Seconds (0 - 240 Sec's)	Page 217 <table border="1"><tr><td>12</td><td>3</td></tr></table>	12	3		
12	3						
Location 416 – 417 <i>Entry Guard Time For STAY Mode</i>	Location 416 Location 417	Increments Of 1 Second (0 - 15 Sec's) Increments Of 16 Seconds (0 - 240 Sec's)	Page 217 <table border="1"><tr><td>0</td><td>0</td></tr></table>	0	0		
0	0						
Location 418 – 419 <i>Delay Alarm Reporting Time</i>	Location 418 Location 419	Increments Of 1 Second (0 - 15 Sec's) Increments Of 16 Seconds (0 - 240 Sec's)	Page 217 <table border="1"><tr><td>0</td><td>0</td></tr></table>	0	0		
0	0						
Location 420 - 421 <i>Sensor Watch Time</i>	Location 420 Location 421	Increments Of Days (Tens Digit) Increments Of Days (Units Digit)	Page 218 <table border="1"><tr><td>0</td><td>0</td></tr></table>	0	0		
0	0						
Location 422 <i>Codepad Lockout Time</i>	Location 422	Increments Of 10 Seconds	Page 218 <table border="1"><tr><td>0</td></tr></table>	0			
0							
Location 423 <i>Siren Run Time</i>	Location 423	Increments Of 1 Minute (0 – 15 Min's)	Page 219 <table border="1"><tr><td>5</td></tr></table>	5			
5							
Location 424 <i>Siren Sound Rate (Slow <-Sound-> Fast)</i>			Page 219 <table border="1"><tr><td>7</td></tr></table>	7			
7							
Location 425 <i>Auto Arming Pre-Alert Time</i>	Location 425	Increments Of 5 Minutes	Page 220 <table border="1"><tr><td>1</td></tr></table>	1			
1							
Location 426 – 429 <i>Auto Arming Time</i>	Location 426 Location 427 Location 428 Location 429	Hour Of The Day (Tens Digit) Hour Of The Day (Units Digit) Minute Of The Day (Tens Digit) Minute Of The Day (Units Digit)	Page 220 <table border="1"><tr><td>0</td><td>0</td><td>0</td><td>0</td></tr></table>	0	0	0	0
0	0	0	0				
Location 430 - 433 <i>Auto Disarming Time</i>	Location 430 Location 431 Location 432 Location 433	Hour Of The Day (Tens Digit) Hour Of The Day (Units Digit) Minute Of The Day (Tens Digit) Minute Of The Day (Units Digit)	Page 221 <table border="1"><tr><td>0</td><td>0</td><td>0</td><td>0</td></tr></table>	0	0	0	0
0	0	0	0				
Location 434 <i>Kiss-Off Wait Time</i>	Location 434	Increments Of 500 ms (500 ms – 8 Sec's)	Page 221 <table border="1"><tr><td>3</td></tr></table>	3			
3							
Location 435 <i>Speaker Beep Volume</i>	Location 435	0 = No Beeps / 15 = Loudest Beeps	Page 221 <table border="1"><tr><td>13</td></tr></table>	13			
13							
Location 436 <i>System Options 1</i>	1 = EDM Smart Lockout Allowed 2 = Horn Speaker Monitor 4 = Strobe Indications For Radio Arm/Disarm 8 = Assign Button 4 On Transmitter To Operate STAY Mode 1		Page 227 <table border="1"><tr><td>1</td></tr></table>	1			
1							
Location 437 <i>System Options 2</i>	1 = Codepad Panic To Be Silent 2 = Codepad Fire To Be Silent 4 = Codepad Medical To Be Silent 8 = Access Denied To Be Silent		Page 228 <table border="1"><tr><td>0</td></tr></table>	0			
0							
Location 438 <i>System Options 3</i>	1 = AC Fail After 1 Hour (Disabled = After 2 Minutes) 2 = Ignore AC Fail 4 = Pulse Count Handover Allowed 8 = Handover Delay To Be Sequential		Page 229 <table border="1"><tr><td>8</td></tr></table>	8			
8							
Location 439 <i>System Options 4</i>	1 = Panel To Power Up Disarmed (If Power Reset) 2 = Arm/Disarm Tracking On Power Up 4 = Internal Crystal To Keep Time 8 = Keyswitch Interface, Night Arm Station Or RE005 Installed		Page 230 <table border="1"><tr><td>0</td></tr></table>	0			
0							

Location 440 <i>Consumer Options 1</i>	1 = Test Reports Only When Armed 2 = Test Report After Siren Reset 4 = Auto Arm In STAY Mode 1 8 = STAY Indicator To Display Day Alarm Status	Page 231	<input type="text" value="0"/>
Location 441 <i>Consumer Options 2</i>	1 = Codepad Display Extinguish After 60 Seconds 2 = Single Button Arming Allowed (AWAY Mode, STAY Mode 1 & 2) 4 = Single Button Disarming Allowed (STAY Mode 1 & 2) 8 = Alarm Memory Reset On Disarm	Page 232	<input type="text" value="2"/>
Location 442 <i>Consumer Options 3</i>	1 = Codepad Fault Alarm Beeps Allowed 2 = Use Digit 3 For Codepad Duress Instead Of Digit 9 4 = Alarms Activate Siren & Strobe In STAY Mode 1 and STAY Mode 2 8 = Zone Tamper Alarms To Be Silent	Page 233	<input type="text" value="5"/>
Location 443 <i>Radio Input Options</i>	1 = DS 304 MHz Receiver (RF3212) 2 = Latching Keypad Input 3 = Momentary Keypad Input 4 = Reserved	Page 234	<input type="text" value="0"/>
Location 478 – 525 <i>Domestic Telephone Numbers</i>		Page 127	
Location 526 <i>Reserved</i>			<input type="text" value="0"/>
Location 527 <i>RF Options</i>	1 = Sound Siren On RF Receiver Fail 2 = Sound Siren On RF Receiver Tamper / Jamming 4 = Unseal Zone That Fails Supervision (Only If Supervision Enabled) 8 = Enable RF Jamming Monitoring	Page 250	<input type="text" value="0"/>
Location 528 – 535 <i>RF Device Mapping (Devices 1 – 8)</i>		Page 250	<input type="text" value="1"/> <input type="text" value="2"/> <input type="text" value="3"/> <input type="text" value="4"/> <input type="text" value="5"/> <input type="text" value="6"/> <input type="text" value="7"/> <input type="text" value="8"/>
Location 536 – 543 <i>RF Device Mapping (Devices 9 – 16)</i>		Page 250	<input type="text" value="0"/> <input type="text" value="0"/> <input type="text" value="0"/> <input type="text" value="0"/> <input type="text" value="0"/> <input type="text" value="0"/> <input type="text" value="0"/> <input type="text" value="0"/>
Location 801 – 808 <i>RF Device Signal Strength (Devices 1 – 8 Read Only)</i>		Page 251	<input type="text" value="0"/> <input type="text" value="0"/> <input type="text" value="0"/> <input type="text" value="0"/> <input type="text" value="0"/> <input type="text" value="0"/> <input type="text" value="0"/> <input type="text" value="0"/>
Location 809 – 816 <i>RF Device Signal Strength (Devices 9 – 16 Read Only)</i>		Page 251	<input type="text" value="0"/> <input type="text" value="0"/> <input type="text" value="0"/> <input type="text" value="0"/> <input type="text" value="0"/> <input type="text" value="0"/> <input type="text" value="0"/> <input type="text" value="0"/>
Location 900 <i>Disable Factory Default</i>	0 = Defaulting Enabled 15 = Defaulting Disabled	Page 118	<input type="text" value="0"/>
Location 901 – 904 <i>System Time</i>	Location 901 Hour Of The Day (Tens Digit) Location 902 Hour Of The Day (Units Digit) Location 903 Minute Of The Day (Tens Digit) Location 904 Minute Of The Day (Units Digit)	Page 222	<input type="text" value="0"/> <input type="text" value="0"/> <input type="text" value="0"/> <input type="text" value="0"/>
Location 905 – 910 <i>System Date</i>	Location 905 Day Of The Month (Tens Digit) Location 906 Day Of The Month (Units Digit) Location 907 Month Of The Year (Tens Digit) Location 908 Month Of The Year (Units Digit) Location 909 Year (Tens Digit) Location 910 Year (Units Digit)	Page 223	<input type="text" value="0"/> <input type="text" value="1"/> <input type="text" value="0"/> <input type="text" value="1"/> <input type="text" value="0"/> <input type="text" value="1"/>

Solution Ultima 880
Programming Sheets

Location 000 – 015

Page 139

Primary Telephone Number For Receiver 1

0 0 0 0 0 0 0 0 0 0 0 0 0 0 0 0

Location 016 – 031

Page 139

Secondary Telephone Number For Receiver 1

0 0 0 0 0 0 0 0 0 0 0 0 0 0 0 0

Location 032

Page 140

Handshake Tone For Receiver 1

- 1 = HI-LO Handshake (Contact ID)
- 2 = 1400 Hz (TX @ 1900 Hz)
- 3 = 2300 Hz (Low Speed Sescoa)

- 4 = No Handshake Required
- 5 = Pager

1

Location 033

Page 141

Transmission Format For Receiver 1

- 1 = Contact ID
- 2 = 4 + 2 Express
- 3 = FSK 300 Baud
- 4 = Domestic

- 5 = Basic Pager
- 6 = Reserved
- 7 = Reserved
- 8 = Reserved

1

Location 034 – 039

Page 141

Subscriber ID Number For Receiver 1

0 0 0 0 0 0

Location 040 – 055

Page 142

Primary Telephone Number For Receiver 2

0 0 0 0 0 0 0 0 0 0 0 0 0 0 0 0

Location 056 – 071

Page 142

Secondary Telephone Number For Receiver 2

0 0 0 0 0 0 0 0 0 0 0 0 0 0 0 0

Location 072

Page 143

Handshake Tone For Receiver 2

- 1 = HI-LO Handshake (Contact ID)
- 2 = 1400 Hz (TX @ 1900 Hz)
- 3 = 2300 Hz (Low Speed Sescoa)

- 4 = No Handshake Required
- 5 = Pager

1

Location 073

Page 144

Transmission Format For Receiver 2

- 1 = Contact ID
- 2 = 4 + 2 Express
- 3 = FSK 300 Baud
- 4 = Domestic

- 5 = Basic Pager
- 6 = Reserved
- 7 = Reserved
- 8 = Reserved

1

Location 074 – 079

Page 144

Subscriber ID Number For Receiver 2

0 0 0 0 0 0

Location 080

Page 145

Dialling Format

- 1 = Australian DTMF (5 Digits/Second)
- 2 = Australian Decadic
- 3 = Alternate DTMF & Decadic (AUST)

- 4 = International DTMF
- 5 = Reversed Decadic
- 6 = Alternate DTMF & Reversed Decadic

1

Location 081 – 112

Page 145

Reserved

Location 113 – 142

Page 146

Telco Arming Sequence

0 0

Location 143 – 158

Page 147

Telco Disarming Sequence

0 0 0 0 0 0 0 0 0 0 0 0 0 0 0 0 0 0

Location 159 – 174

Page 147

Call Back Telephone Number

0 0 0 0 0 0 0 0 0 0 0 0 0 0 0 0

Location 175

Page 148

Ring Count

- 0 = Panel Will Not Answer
- 1 – 13 = No Of Rings Until Panel Answers

- 14 = Answering Machine Bypass 2
- 15 = Answering Machine Bypass 1

8

Location 176

Page 149

Telephone Line Fault Options

- 1 = Display FAULT Indicator When Telephone Line Fails
- 2 = Sound Alarm When System Is Armed
- 4 = Sound Alarm When System Is Disarmed
- 8 = Reserved

0

Location 748 - 749

Page 150

Ring Burst Count

- Location 748 Increments Of 5 ms
- Location 749 Increments Of 80 ms

4 6

Location 177 Page 153
Dialler Options 1
 1 = Dialler Reporting Functions Allowed
 2 = Remote Arming Via The Telephone Allowed
 4 = Answering Machine Bypass Only When Armed
 8 = Use Bell 103 For FSK Format (Disabled – CCITT V21) 9

Location 178 Page 154
Dialler Options 2
 1 = Open/Close Reports Only If Previous Alarm
 2 = Open/Close Reports For STAY Mode 1 and STAY Mode 2
 4 = Delay Siren Until Transmission Complete
 8 = Extend Time To Wait For Handshake From 30 Seconds To 55 Seconds 0

Location 179 Page 155
Dialler Options 3
 1 = Set DTMF Dialling Pulses To 1 Digit/Second
 2 = Lockout Telephone Line Fail Alarm **(New - Software Version 1.03)**
 4 = Change Decadic Dialling To 60/40
 8 = Reserved 0

Location 179 **(New - Software Version 1.04)** Page 155
Dialler Options 3
 1 = Set DTMF Dialling Pulses To 1 Digit/Second
 2 = Lockout Telephone Line Fail Alarm **(New - Software Version 1.03)**
 4 = Change Decadic Dialling To 60/40
 8 = External Modem Module (CC811) Required For FSK (V1.09+) 2

Location 180 Page 124/156
Alarm Link Options
 1 = Upload/Download Allowed
 2 = Call Back Phone Number Required For Upload/Download
 4 = Exit Upload/Download Connection On Alarm
 8 = External Modem Module (CC811) Required For Upload/Download 3

Location 181 – 184 Page 158
Installer Code
1 2 3 4

Location 185 – 264 Page 159
User Codes

	Location 185 - 189		Location 190 - 194																	
	User Code 1	2	5	8	0	10	User Code 2	15	15	15	15	2								
Location 195 - 199	User Code 3	15	15	15	15	2	Location 200 - 204	User Code 4	15	15	15	15	2	Location 205 - 209	User Code 5	15	15	15	15	2
Location 210 - 214	User Code 6	15	15	15	15	2	Location 215 - 219	User Code 7	15	15	15	15	2	Location 220 - 224	User Code 8	0	15	15	15	3
Location 225 - 229	Radio Code 9	15	15	15	15	2	Location 230 - 234	Radio Code 10	15	15	15	15	2	Location 235 - 239	Radio Code 11	15	15	15	15	2
Location 240 - 244	Radio Code 12	15	15	15	15	2	Location 245 - 249	Radio Code 13	15	15	15	15	2	Location 250 - 254	Radio Code 14	15	15	15	15	2
Location 255 - 259	Radio Code 15	15	15	15	15	2	Location 260 - 264	Radio Code 16	15	15	15	15	2							
		15	15	15	15	0														
	User Code					Priority														

Priority	Description	Priority	Description
0	Arm/Disarm	6	Arm/Disarm + Code To Isolate + Open/Close Report
1	Arm Only	8	Arm/Disarm + Master Code Functions
2	Arm/Disarm + Open/Close Report	10	Arm/Disarm + Master Code Functions + Open/Close Report
3	Arm Only + Close Report	12	Arm/Disarm + Master Code Functions + Code To Isolate
4	Arm/Disarm + Code To Isolate	14	Arm/Disarm + Master Code Functions + Code To Isolate + Open/Close Report

Table 175: User Code Priority Levels

Location 265

Page 164

Day Alarm Zones

1 = Zone 1
2 = Zone 2

4 = Zone 3
8 = Zone 4

0

Location 266

Page 166

EOL Resistor Value

0 = No End Of Line Resistor
1 = 1K
2 = 1K5
3 = 2K2
4 = 3K3
5 = 3K9
6 = 4K7
7 = 5K6
8 = 6K8

9 = 10K
10 = 12K
11 = 22K
12 = Reserved
13 = Reserved
14 = Split EOL (3K3/6K8) With Tamper (1K)
15 = Split EOL (3K3/6K8) – Six Burglary Zones and Two 24 Hour Zones

15

Location 267 – 322

Page 170

Zones

	<i>Zone 1</i> Location 267 - 273	<i>Zone 2</i> Location 274 - 280
	2 0 0 1 14 1 1	1 0 0 1 14 1 1
<i>Zone 3</i> Location 281 - 287	<i>Zone 4</i> Location 288 - 294	<i>Zone 5</i> Location 295 - 301
1 0 0 1 14 1 1	1 0 0 1 14 1 1	0 0 0 1 14 1 1
<i>Zone 6</i> Location 302 - 308	<i>Zone 7</i> Location 309 - 315	<i>Zone 8</i> Location 316 - 322
0 0 0 1 14 1 1	0 0 0 1 14 1 1	9 0 0 1 12 1 1
<input type="checkbox"/>	<input type="checkbox"/>	<input type="checkbox"/>
<i>Zone Type</i>	<i>Zone Pulse Count</i>	<i>Zone Pulse Count Time</i>
	<input type="checkbox"/>	<input type="checkbox"/>
	<i>Zone Option 1</i>	<i>Zone Option 2</i>
	<input type="checkbox"/>	<input type="checkbox"/>
	<i>Report Code</i>	<i>Dialler Options</i>

Zone Types

There are fifteen different zone types to choose from. Each zone contains eight locations. Zones 1 to 8 are fully programmable.

<i>Zone Type</i>	<i>Description</i>	<i>Zone Type</i>	<i>Description</i>
0	Instant	8	24 Hour Hold-Up
1	Handover	9	24 Hour Tamper
2	Delay-1	10	Reserved
3	Delay-2	11	Keyswitch
4	Reserved	12	24 Hour Burglary
5	Reserved	13	24 Hour Fire
6	24 Hour Medical	14	Chime Only
7	24 Hour Panic	15	Zone Not Used

Table 176: Available Zone Types

Zone Pulse Count Settings

The pulse count settings for each zone can be programmed between 0 - 15.

Zone Pulse Count Time

Zone pulse count time is the time frame or period over which the number of pulses must register.

<i>20 ms Loop Response Time Zone Pulse Count Time</i>		<i>150 ms Loop Response Time Zone Pulse Count Time</i>	
0	0.5 Second	8	20 Seconds
1	1 Second	9	30 Seconds
2	2 Seconds	10	40 Seconds
3	3 Seconds	11	50 Seconds
4	4 Seconds	12	60 Seconds
5	5 Seconds	13	90 Seconds
6	10 Seconds	14	120 Seconds
7	15 Seconds	15	200 Seconds

Table 177: Zone Pulse Count Time Options

Zone Options 1

<i>Option</i>	<i>Description</i>
1	Lockout Siren/Lockout Dialler
2	Delay Alarm Reporting
4	Silent Alarm
8	Sensor Watch

Table 178: Zone Options 1

Zone Options 2

<i>Option</i>	<i>Description</i>
1	Isolated In STAY Mode 1
2	Zone Isolation Allowed
4	Forced Arming Allowed
8	Enable Zone Restore Report

Table 179: Zone Options 2

Zone Dialler Options

<i>Option</i>	<i>Description</i>
0	No Report Required
1	Receiver 1
2	Receiver 2
4	Receiver 1 + 2
8	Receiver 2 Only When Receiver 1 Fails

Table 180: Zone Dialler Options

Zone Descriptions

Use this table as a reference to indicate what each zone is connected to.

<i>Zone</i>	<i>Description</i>	<i>Zone</i>	<i>Description</i>
1		5	
2		6	
3		7	
4		8	

Table 181: Zone Descriptions

Location 323 <i>Swinger Shutdown Count For Siren</i>			Page 181	3
Location 324 <i>Swinger Shutdown Count For Dialler</i>			Page 182	6
Location 325 – 326 <i>Zone Status - Zone Tamper Report</i>	Location 325 Location 326	Zone Tamper Report Zone Tamper Restore Report	Page 184	0 0
Location 327 – 328 <i>Zone Status - Walk Test Report</i>	Location 327 Location 328	Walk Test Enable Report Walk Test Disable Report	Page 184	0 0
Location 329 – 330 <i>Zone Status - Bypass Reports</i>	Location 329 Location 330	Zone Bypass Report Zone Bypass Restore Report	Page 185	9 8
Location 331 – 332 <i>Zone Status - Trouble Reports</i>	Location 331 Location 332	Zone Trouble Report Zone Trouble Restore Report	Page 185	2 3
Location 333 – 334 <i>Zone Status - Sensor Watch Reports</i>	Location 333 Location 334	Sensor Watch Report Sensor Watch Restore Report	Page 186	4 5
Location 335 <i>Zone Status - Alarm Restore Code</i>			Page 186	14
Location 336 <i>Zone Status Reporting Options</i>		0 = No Report Required 1 = Receiver 1 2 = Receiver 2 4 = Receiver 1 + 2 8 = Receiver 2 Only When Receiver 1 Fails	Page 186	1
Location 337 <i>RF Supervision Time</i>	Location 337	Increments Of 6 Hours (0 – 90 Hours)	Page 187	0
Location 338 – 339 <i>RF Low Battery Report</i>	Location 338 Location 339	RF Low Battery Report RF Low Battery Restore Report	Page 187	6 8
Location 340 – 341 <i>RF Receiver Trouble Report</i>	Location 340 Location 341	RF Receiver Trouble Report (Tens Digit) RF Receiver Trouble Report (Units Digit)	Page 188	7 9
Location 342 – 343 <i>RF Receiver Trouble Restore Report</i>	Location 342 Location 343	RF Receiver Trouble Restore Report (Tens Digit) RF Receiver Trouble Restore Report (Units Digit)	Page 188	7 11
Location 344 <i>RF Dialler Options</i>		0 = No Report Required 1 = Receiver 1 2 = Receiver 2 4 = Receiver 1 + 2 8 = Receiver 2 Only When Receiver 1 Fails	Page 188	1
Location 345 – 346 <i>Open/Close Reports</i>	Location 345 Location 346	Opening Report Closing Report	Page 189	11 12
Location 347 <i>Open/Close Reporting Options</i>		0 = No Report Required 1 = Receiver 1 2 = Receiver 2 4 = Receiver 1 + 2 8 = Receiver 2 Only When Receiver 1 Fails	Page 189	1
Location 348 <i>Codepad Duress Report</i>			Page 190	6
Location 349 – 350 <i>Codepad Panic Report</i>			Page 190	7 15
Location 351 – 352 <i>Codepad Fire Report</i>			Page 191	7 14

Location 353 – 354
Codepad Medical Report

Page 191

7	13
---	----

Location 355
Codepad Reporting Options

- 0 = No Report Required
- 1 = Receiver 1
- 2 = Receiver 2
- 4 = Receiver 1 + 2
- 8 = Receiver 2 Only When Receiver 1 Fails

Page 192

1

Location 356 – 357
System Status – Fuse Fail Report

Page 192

10	3
----	---

Location 358 – 359
System Status – Fuse Fail Restore Report

Page 192

10	8
----	---

Location 360 – 361
System Status – AC Fail Report

Page 193

10	2
----	---

Location 362 – 363
System Status - AC Fail Restore Report

Page 193

10	7
----	---

Location 364 – 365
System Status - Low Battery Report

Page 194

10	1
----	---

Location 366 – 367
System Status - Low Battery Restore Report

Page 194

10	6
----	---

Location 368 – 370
System Status – Access Denied

- Location 368 Code Retries
- Location 369 Reporting Code – Tens Digit
- Location 370 Reporting Code – Units Digit

Page 195

6	7	12
---	---	----

Location 371
System Status Reporting Options

- 0 = No Report Required
- 1 = Receiver 1
- 2 = Receiver 2
- 4 = Receiver 1 + 2
- 8 = Receiver 2 Only When Receiver 1 Fails

Page 196

1

Location 372 – 378
Test Reporting Time

- Location 372 Actual Hour Of The Day (Tens Digit)
- Location 373 Actual Hour Of The Day (Units Digit)
- Location 374 Actual Minute Of The Day (Tens Digit)
- Location 375 Actual Minute Of The Day (Units Digit)
- Location 376 Test Report Code (Tens Digit)
- Location 377 Test Report Code (Units Digit)
- Location 378 Repeat Interval In Days

0	0	0	0	7	1	0
---	---	---	---	---	---	---

Page 197

Location 379
Test Reporting Dialler Options

- 0 = No Report Required
- 1 = Receiver 1
- 2 = Receiver 2
- 4 = Receiver 1 + 2
- 8 = Receiver 2 Only When Receiver 1 Fails

Page 197

1

Location 380 – 409
Output Configurations

Page 200

Output 1

1	14	0	0	0	0
---	----	---	---	---	---

Location 380 - 385

Default For
Horn Speaker

Output 2

2	7	10	2	1	5
---	---	----	---	---	---

Location 386 - 391

Default For
Fire Alarm Verification

Strobe

2	0	6	4	0	8
---	---	---	---	---	---

Location 392 – 397

Default For Strobe
(Reset In 8 Hrs)

Relay

1	15	1	0	0	0
---	----	---	---	---	---

Location 398 – 403

Default For
Sirens Running

Codepad

0	13	2	1	0	1
---	----	---	---	---	---

Location 404 – 409

Default For Entry/Exit
Warning + Day Alarm



Event Type



Polarity



Time Base



Time Multiplier

Location 410 – 411 <i>Entry Timer 1</i>	Location 410 Location 411	Increments Of 1 Second (0 - 15 Sec's) Increments Of 16 Seconds (0 - 240 Sec's)	Page 216 <table border="1"><tr><td>4</td><td>1</td></tr></table>	4	1		
4	1						
Location 412 – 413 <i>Entry Timer 2</i>	Location 412 Location 413	Increments Of 1 Second (0 - 15 Sec's) Increments Of 16 Seconds (0 - 240 Sec's)	Page 216 <table border="1"><tr><td>8</td><td>2</td></tr></table>	8	2		
8	2						
Location 414 – 415 <i>Exit Time</i>	Location 414 Location 415	Increments Of 1 Second (0 - 15 Sec's) Increments Of 16 Seconds (0 - 240 Sec's)	Page 217 <table border="1"><tr><td>12</td><td>3</td></tr></table>	12	3		
12	3						
Location 416 – 417 <i>Entry Guard Time For STAY Mode</i>	Location 416 Location 417	Increments Of 1 Second (0 - 15 Sec's) Increments Of 16 Seconds (0 - 240 Sec's)	Page 217 <table border="1"><tr><td>0</td><td>0</td></tr></table>	0	0		
0	0						
Location 418 – 419 <i>Delay Alarm Reporting Time</i>	Location 418 Location 419	Increments Of 1 Second (0 - 15 Sec's) Increments Of 16 Seconds (0 - 240 Sec's)	Page 217 <table border="1"><tr><td>0</td><td>0</td></tr></table>	0	0		
0	0						
Location 420 - 421 <i>Sensor Watch Time</i>	Location 420 Location 421	Increments Of Days (Tens Digit) Increments Of Days (Units Digit)	Page 218 <table border="1"><tr><td>0</td><td>0</td></tr></table>	0	0		
0	0						
Location 422 <i>Codepad Lockout Time</i>	Location 422	Increments Of 10 Seconds	Page 218 <table border="1"><tr><td>0</td></tr></table>	0			
0							
Location 423 <i>Siren Run Time</i>	Location 423	Increments Of 1 Minute (0 – 15 Min's)	Page 219 <table border="1"><tr><td>5</td></tr></table>	5			
5							
Location 424 <i>Siren Sound Rate (Slow <-Sound-> Fast)</i>			Page 219 <table border="1"><tr><td>7</td></tr></table>	7			
7							
Location 425 <i>Auto Arming Pre-Alert Time</i>	Location 425	Increments Of 5 Minutes	Page 220 <table border="1"><tr><td>1</td></tr></table>	1			
1							
Location 426 – 429 <i>Auto Arming Time</i>	Location 426 Location 427 Location 428 Location 429	Hour Of The Day (Tens Digit) Hour Of The Day (Units Digit) Minute Of The Day (Tens Digit) Minute Of The Day (Units Digit)	Page 220 <table border="1"><tr><td>0</td><td>0</td><td>0</td><td>0</td></tr></table>	0	0	0	0
0	0	0	0				
Location 430 - 433 <i>Auto Disarming Time</i>	Location 430 Location 431 Location 432 Location 433	Hour Of The Day (Tens Digit) Hour Of The Day (Units Digit) Minute Of The Day (Tens Digit) Minute Of The Day (Units Digit)	Page 221 <table border="1"><tr><td>0</td><td>0</td><td>0</td><td>0</td></tr></table>	0	0	0	0
0	0	0	0				
Location 434 <i>Kiss-Off Wait Time</i>	Location 434	Increments Of 500 ms (500 ms – 8 Sec's)	Page 221 <table border="1"><tr><td>3</td></tr></table>	3			
3							
Location 435 <i>Speaker Beep Volume</i>	Location 435	0 = No Beeps / 15 = Loudest Beeps	Page 221 <table border="1"><tr><td>13</td></tr></table>	13			
13							
Location 436 <i>System Options 1</i>	1 = EDM Smart Lockout Allowed 2 = Horn Speaker Monitor 4 = Strobe Indications For Radio Arm/Disarm 8 = Assign Button 4 On Transmitter To Operate STAY Mode 1		Page 227 <table border="1"><tr><td>1</td></tr></table>	1			
1							
Location 437 <i>System Options 2</i>	1 = Codepad Panic To Be Silent 2 = Codepad Fire To Be Silent 4 = Codepad Medical To Be Silent 8 = Access Denied To Be Silent		Page 228 <table border="1"><tr><td>0</td></tr></table>	0			
0							
Location 438 <i>System Options 3</i>	1 = AC Fail After 1 Hour (Disabled = After 2 Minutes) 2 = Ignore AC Fail 4 = Pulse Count Handover Allowed 8 = Handover Delay To Be Sequential		Page 229 <table border="1"><tr><td>8</td></tr></table>	8			
8							
Location 439 <i>System Options 4</i>	1 = Panel To Power Up Disarmed (If Power Reset) 2 = Arm/Disarm Tracking On Power Up 4 = Internal Crystal To Keep Time 8 = Keyswitch Interface, Night Arm Station Or RE005 Installed		Page 230 <table border="1"><tr><td>0</td></tr></table>	0			
0							

Location 440 Page 231
Consumer Options 1
 1 = Test Reports Only When Armed
 2 = Test Report After Siren Reset
 4 = Auto Arm In STAY Mode 1
 8 = STAY Indicator To Display Day Alarm Status 0

Location 441 Page 232
Consumer Options 2
 1 = Codepad Extinguish Mode
 2 = Single Button Arming Allowed (AWAY Mode, STAY Mode 1 & 2)
 4 = Single Button Disarming From STAY Mode 1 & 2)
 8 = Alarm Memory Reset On Disarm 2

Location 442 Page 233
Consumer Options 3
 1 = Codepad Fault Alarm Beeps Allowed
 2 = Use Digit 3 For Codepad Duress Instead Of Digit 9
 4 = Alarms Activate Siren & Strobe In STAY Mode 1 and STAY Mode 2
 8 = Zone Tamper Alarms To Be Silent 5

Location 443 Page 234
Radio Input Options
 1 = DS 304 MHz Receiver (RF3212)
 2 = Latching Keyswitch Input
 3 = Momentary Keyswitch Input
 4 = Reserved 0

Location 444 Page 241
Partitioning Options 1
 1 = First To Open/Last To Close Reporting
 2 = Area 1 Codepad Connected To Data Terminal
 4 = Reset Sirens From Any Area Allowed
 8 = Master Codepad To Display AUX Indicator When Using Telephone Line 0

Location 445 Page 242
Partitioning Options 2
 1 = Lock Area 1 To Receiver 1 and Lock Area 2 To Receiver 2
 2 = User Code Allowed To Arm/Disarm Both Areas At same Time (Code + 0 + #)
 4 = Reserved
 8 = Reserved 0

Location 446 – 453 Page 243
Zone Allocations For Area 1 0 0 0 0 0 0 0 0 0

Location 454 – 461 Page 243
Zone Allocations For Area 2 0 0 0 0 0 0 0 0 0

Location 462 – 477 Page 245
User Code Allocations

Location 462 Areas For User #1 0	Location 463 Areas For User #2 0	Location 464 Areas For User #3 0	Location 465 Areas For User #4 0
Location 466 Areas For User #5 0	Location 467 Areas For User #6 0	Location 468 Areas For User #7 0	Location 469 Areas For User #8 0
Location 470 Areas For User #9 0	Location 471 Areas For User #10 0	Location 472 Areas For User #11 0	Location 473 Areas For User #12 0
Location 474 Areas For User #13 0	Location 475 Areas For User #14 0	Location 476 Areas For User #15 0	Location 477 Areas For User #16 0

Location 478 – 525 Page 127
Domestic Telephone Numbers

Location 526 Page 250
Reserved 0

Location 527 Page 250
RF Option
 1 = Sound Siren On RF Receiver Fail
 2 = Sound Siren On RF Receiver Tamper / Jamming
 4 = Unseal Zone That Fails Supervision (Only If Supervision Enabled)
 8 = Enable RF Jamming Monitoring 0

Location 528 – 535
RF Device Mapping (Devices 1 – 8)

Page 250

1	2	3	4	5	6	7	8
---	---	---	---	---	---	---	---

Location 536 – 543
RF Device Mapping (Devices 9 – 16)

Page 250

0	0	0	0	0	0	0	0
---	---	---	---	---	---	---	---

Location 801 – 808
RF Device Signal Strength (Devices 1 – 8 Read Only)

Page 251

0	0	0	0	0	0	0	0
---	---	---	---	---	---	---	---

Location 809 – 816
RF Device Signal Strength (Devices 9 – 16 Read Only)

Page 251

0	0	0	0	0	0	0	0
---	---	---	---	---	---	---	---

Location 900
Disable Factory Default

0 = Defaulting Enabled
15 = Defaulting Disabled

Page 118

0

Location 901 – 904
System Time

Page 222

Location 901	Hour Of The Day (Tens Digit)
Location 902	Hour Of The Day (Units Digit)
Location 903	Minute Of The Day (Tens Digit)
Location 904	Minute Of The Day (Units Digit)

0	0	0	0
---	---	---	---

Location 905 – 910
System Date

Page 223

Location 905	Day Of The Month (Tens Digit)
Location 906	Day Of The Month (Units Digit)
Location 907	Month Of The Year (Tens Digit)
Location 908	Month Of The Year (Units Digit)
Location 909	Year (Tens Digit)
Location 910	Year (Units Digit)

0	1	0	1	0	1
---	---	---	---	---	---

Index

2		B	
2 Wire Smoke Detector Interface	256	Basic Pager.....	134
24 Hour Zone.....	261	Basic Pager Reporting.....	134
4		Battery Testing.....	259
4 + 2 Reporting Format	133	Bell Test.....	94
A		Bypass Reports.....	185
AC Mains		C	
Fail In 1 Hour	229	Call Back Telephone Number	147
Ignore Fail Indication	229	Cellular Diallers	255
Report	193	Code Retries.....	195
Restore Report	193	Codepad	259
AC Mains Failure	54	Buzzer	200
Access Codes		Buzzer Tone Change	97
Installer Code.....	158	CP5 Eight Zone Area Addressable Codepad.....	255
User Code Priority Level	161	CP5 Master Partitioned	255
User Codes.....	159	Determine Area	97
Access Denied		DIP Switches.....	246
Code Retries	195	Codepad Duress	47, 190
Access Denied To Be Silent	228	Codepad Duress Report.....	190
Alarm Condition	259	Codepad Extinguish Mode.....	232
Alarm Link	124, 156	Codepad Fire	47, 191, 228
Direct Connect.....	123	Codepad Fire Report	191
Enable Alarm Link Call Back.....	124, 156	Codepad Fire To Be Silent.....	228
Enable Upload/Download.....	124, 156	Codepad Indicators	
External Modem Module.....	124	Area Display	36, 237
Initiate Modem Call.....	96	Area On/Off	35, 237
Remote Connect	122	Audible.....	30, 34, 37, 239
Remote Connect With Call Back Verification.....	123	AUX.....	36, 238
Remote Connect With Customer Control	122	AWAY	28, 31
Remote Connect Without Call Back Verification...	123	FAULT.....	29, 33, 37, 238
Terminate Session If Report Pending	124, 156	MAINS.....	29, 32, 37, 238
Alarm Link Software	254	OFF Indicator/Zone Sealed	33
Alarm Memory Reset On Disarm.....	232	ON Indicator/Zone In Alarm.....	33
Alarm Reporting	175	PARTIAL.....	36, 237
Answering Machine Bypass	148, 259	Programming Mode	33
Only When Armed.....	153	STAY	29, 32
Area Display Indicator.....	36, 237	System Disarmed	32
Area On/Off Indicator.....	35, 237	Zone	28, 31, 35, 236
Armed	259	Codepad Lockout Time.....	218
Arming		Codepad Medical	47, 191, 228
Both Areas At Same Time	76, 92	Codepad Medical Report.....	191
In AWAY Mode	40, 93	Codepad Medical To Be Silent	228
In STAY Mode 1	42, 93	Codepad Panic.....	47, 190, 228
In STAY Mode 2	45, 94	Codepad Panic Report.....	190
Single Button Operation	232	Codepad Panic To Be Silent.....	228
Via Telephone.....	100, 153	Codepad Reporting Options	192
Audible Indicators	30, 34, 37, 239	Codepads	
Auto Arm In STAY Mode 1	231	CP5 Eight Zone LED Codepad	28
Auto Arming Pre-Alert Timer	220	CP5 Eight Zone Master Partitioned.....	31
Auto Arming Time	220	CP5 Master Partitioned Codepad	236
Auto Disarming Time	221	Command 958 - Enable/Disable Zone Status.....	108
Automatic Stepping Of Locations	115	Command 959 - Test Programming Key	109
AUX Indicator	36, 238	Command 960 - Exit Installer's Programming Mode..	110
AWAY Indicator	28, 31	Command 961 - Reset Control Panel Back To Factory	
AWAY Mode	259	Default.....	110
Arming.....	40, 93	Command 962 - Copy Control Panel Memory To	
Disarming	41	Programming Key	111
AWAY or #	259	Command 963 - Copy From Programming Key To	
		Control Panel.....	112
		Command 964 - Erase Programming Key	113
		Command 965 - Set Up Domestic Dialling.....	114

Command 966 - Enable/Disable Automatic Stepping	115	Answering Machine Bypass Only When Armed...	153
Command 999 - Display Panel Type/Software Version	117	Bell 103 For FSK Format	153
Communciation Fail	54	Disable Dialler Reporting Functions	153
Component Overlay	263	Remote Arming Via Telephone	153
Connections Of Split EOL Using N/O Contacts	168	Dialler Options 2	
Connections Of Split EOL With Tamper Circuit	167	Delay Siren Until Transmission Complete	154
Consumer Options 1	231	Extend Time To Wait For Handshake	154
Auto Arm In STAY Mode 1	231	Open/Close Reports In STAY Mode	154
Enable STAY Indicator To Display Day Alarm Status	231	Open/Close Reports Only If Previous Alarm Has Occurred	154
Send Test Report After Siren Reset	231	Dialler Options 3	
Send Test Reports Only If Armed	231	Change Decadic Dialling To 60/40	155
Consumer Options 2	232	Modem Module Required For FSK	155
Alarm Memory Reset On Disarm	232	Set DTMF Dialling Pulses To 1 Digit/Second	155
Enable Codepad Extinguish Mode	232	Dialler Reporting Formats	130
Single Button Arming	232	Dialling Format	145
Single Button Disarming	232	Disable Factory Default	118
Consumer Options 3		Disarmed	259
Codepad Fault Alarm Beeps	233	Disarming	
Operation Of Siren & Strobe In STAY Mode	233	Automatic	221
Use Digit 3 For Duress Instead Of Digit 9	233	Both Areas At Same Time	76, 92
Contact ID Format	130	From AWAY Mode	41
Control Panel To Power Up Disarmed	230	From STAY Mode 1	44
Copy Control Panel Memory To Programming Key	111	From STAY Mode 2	46
Copy From Programming Key To Control Panel	112	Single Button Operation	232
D		Domestic Dialling	
Date and Time	53, 89, 223	Acknowledging Alarm Report	126
Day Alarm	164, 259	Changing Domestic Telephone Numbers	66, 81
Latching	164	Command 965	114
Operation	165	Disable	67, 69, 70, 72, 82, 84, 85, 87, 128
Resetting	164	Format	126
Status Indicator	231	Function	126
Turning On/Off	95	Setting Up & Programming	127
Decadic Dialling To 60/40	155	DTMF Dialling Pulses To 1 Digit/Sec	155
Defaulting The Control Panel	110, 119	Dual Reporting	259
Delay Alarm Reporting Time	217	Duress Alarm	47
Delay Siren Until Transmission Complete	154	E	
Delete		E2 Fault	53
RF Zones	64	EDM Smart Watch	227
Detectors	259	EDMSAT	72, 202, 254, 259
Dialler	259	Entry Guard Timer For STAY Mode	42, 45, 217
Dialler Information		Entry Time	259
Answering Machine Bypass	148	Entry Timer 1	216
Call Back Telephone Number	147	Entry Timer 2	216
Dialling Format	145	Entry Warning	259
Handshake Tone For Receiver 1	140	EOL Resistor Value	166
Handshake Tone For Receiver 2	143	Erase Programming Key	113
Primary Telephone Number For Receiver 1	139	Event Memory Recall Mode	75, 91
Primary Telephone Number For Receiver 2	142	Exit Installer's Programming Mode	110
Programing Telephone Numbers	138	Exit Time	217, 260
Ring Count	148	External Equipment	260
Secondary Telephone Number For Receiver 1	139	F	
Secondary Telephone Number For Receiver 2	142	Fault	
Subscriber ID Number For Receiver 1	141	AC Mains Failure	54
Subscriber ID Number For Receiver 2	144	Beeps	233
Telco Arming Sequence	146	Fault Analysis	51
Telco Disarming Sequence	147	Determine Fault Type	51
Telephone Line Fault Options	149	Fault Analysis Mode	
Transmission Format For Receiver 1	141	Determine Type	95
Transmission Format For Receiver 2	144	Exit	95
Dialler Options 1		Fault Descriptions	53
Allow Dialler Reporting Functions	153	Communciation Fail	54

Date and Time	53	Setting STAY Mode 2 Zones	71, 86
E2 Fault	53	Telephone Monitor Mode.....	73
Fuse Fail	53	Walk Test Mode.....	74
Horn Speaker	53	Installer's Programming Commands	
Low Battery	53	958 - Enable/Disable Zone Status	108
RF Low Battery	53	959 - Test Programming Key	109
RF Receiver Fail.....	53	960 - Exit Installer's Programming Mode	110
Sensor Watch.....	54	961 - Reset Control Panel Back To Factory Default	
System Fault	53	110
Tamper Fail.....	54	962 - Copy Panel Memory To Programming Key ..	111
Telephone Line Fail.....	53	963 - Copy From Programming Key To Panel	112
FAULT Indicator.....	29, 33, 37, 238	964 - Erase Programming Key	113
Features		965 - Set Up Domestic Dialling	114
Solution 844.....	19	966 - Automatic Stepping Of Locations.....	115
Solution 862.....	20	999 - Display Panel Type/Software Version Number	
Solution 880.....	21	117
Fire Alarm	47	Internal Crystal To Keep Time.....	230
Forced Arming.....	40, 43, 45, 179, 260	Introduction.....	18
FSK Format		Invalid Code.....	195, 218, 228
Ext Modem Module Required	155	Isolate In STAY Mode 1	179
Transmission.....	141, 144	Isolating Allowed.....	179
Use Bell 103	153	Isolating Zones.....	48
Fuse Fail	53	Code To Isolate	50
G		Standard Method	49
Glossary Of Terms.....	259	K	
H		Keyswitch Zone	172
Hand Held Dialler Tester.....	255	Options.....	177
Hand Held Programmer.....	105, 254	L	
Hand Held Radio Remote Control.....	260	Latching Outputs	
Hand Held Transmitters.....	254	Resetting.....	96
Handover	171	Lockout Dialler	175, 260
Delay.....	260	Lockout Siren.....	175, 260
Delay To Be Sequential	229	Lockout Telephone Line Fail Alarm	155
Handshake		Low Battery.....	53, 187
Extend Time To Wait	154	Report.....	194
Handshake Tone For Receiver 1.....	140	Restore Report.....	194
Handshake Tone For Receiver 2.....	143	M	
Hold Down Function		MAINS Indicator	29, 32, 37, 238
Arm In AWAY Mode.....	93	Master Code	260
Arm In STAY Mode 1	93	Master Code Function	
Arm In STAY Mode 2	94	Arm/Disarm Both Areas At Same Time	76
Bell Test.....	94	Changing & Deleting Remote Radio Codes.....	79
Codepad Buzzer Tone Change	97	Changing & Deleting User Codes	77
Fault Analysis Mode.....	95	Changing Domestic Telephone Numbers.....	81
Horn Speaker Test	94	Event Memory Recall	91
Initiate Modem Call.....	96	Setting Date and Time.....	89
Reset Latching Outputs.....	96	Turning Outputs ON/OFF	87
Send Test Report	97	Walk Test Mode	90
Strobe Test.....	94	Master Partitioned Codepad	
Turning Day Alarm On/Off.....	95	Area Display Indicators.....	36, 237
Horn Speaker	53	Area On/Off Indicators	35, 237
Monitor	227	Audible Indicators	37, 239
Test	94	AUX Indicator.....	36, 238
I		FAULT Indicator	37, 238
Installer Code.....	158	MAINS Indicator	37, 238
Installer Code Function		PARTIAL Indicator	36, 237
Change Telco Arm/Disarm Sequence.....	68	Zone Indicators.....	35, 236
Changing Domestic Phone Numbers	66	Medical Alarm	47
Event Memory Recall	75	Modem Call.....	96
Satellite Siren Service Mode.....	72	Modem Module	124
Set First Test Report	65	Monitoring Station	260

Index	309
N	
New Zealand Telepermit Notes.....	274
Night Arm Station.....	230, 255
O	
OFF Indicator/Zone Sealed.....	33
ON Indicator/Zone In Alarm.....	33
Open/Close Reports.....	189
In STAY Mode.....	154
Only If Previous Alarm Has Occurred.....	154
Reporting Options.....	189
Option Bits.....	107
Optional Equipment	
2 Channel Radio Interface.....	254
2 Wire Smoke Detector Interface.....	256
Alarm Link Software.....	254
Cellular Diallers.....	255
CP5 Eight Zone Area Addressable.....	255
CP5 Eight Zone LCD Codepad.....	255
CP5 Eight Zone LED Codepad.....	255
CP5 Master Partitioned Codepad.....	255
EDMSAT - Satellite Siren.....	254
Hand Held Dialler Tester.....	255
Hand Held Programmer.....	254
Hand Held Transmitters - 304 Mhz.....	254
Night Arm Station.....	255
Phone Controller.....	255
Programming Key.....	254
PS100 Power Supply Module.....	255
Radio Key/Keypress Interface.....	256
Solution Codepad Mimic Board.....	256
TF008 Plug Pack.....	256
Output 1.....	200
Output 2.....	200
Output Event Type.....	202
AC Fail.....	204
AC Mains 60 Hz or 50 Hz.....	209
Alarm When In AWAY Mode.....	206
Alarm When In STAY Mode.....	206
Any Areas Armed.....	209
Any Areas Disarmed.....	209
Area 1 Codepad Data Terminal.....	210
Area 1 Has Zone Unsealed.....	209
Area 1 In Alarm.....	209
Area 1 Is Armed.....	209
Area 1 Is Disarmed.....	209
Area 2 Codepad Data Terminal.....	210
Area 2 Has Zone Unsealed.....	209
Area 2 In Alarm.....	209
Area 2 Is Armed.....	209
Area 2 Is Disarmed.....	209
Armed In AWAY Mode.....	202
Armed In STAY Mode.....	202
Auto Arm Pre-Alert Time.....	202
Codepad Duress Alarm.....	205
Codepad Fire Alarm.....	205
Codepad Medical Alarm.....	205
Codepad Panic (Multi-Break).....	208
Codepad Panic Alarm.....	205
Codepad Tamper.....	205
Communications Failure.....	208
Communications Failure After 3 Unsuccessful Calls.....	208
Day Alarm Enabled.....	204
Day Alarm Latching.....	204
Day Alarm Resetting.....	203
Dialler Active.....	208
Dialler Disabled.....	208
EDMSAT - Satellite Siren.....	202
Entry Warning.....	203
Entry Warning + Day Alarm Resetting.....	203
Exit Warning.....	203
Exit Warning + Entry Warning.....	203
Exit Warning Finished.....	203
Exit Warning With All Zones Sealed Or Entry Warning.....	202
Fire Alarm Latching.....	206
Fire Alarm Resetting.....	206
Fire Alarm Verification.....	207
Fuse Fail.....	204
Global Chime.....	208
Horn Speaker.....	205
Horn Speaker Monitor Fail.....	204
Kiss-Off After Exit Time.....	203
Kiss-Off Received.....	204
Low Battery.....	204
Mimic System Fault.....	206
Mimic Zone 1.....	208
Mimic Zone 2.....	208
Mimic Zone 3.....	208
Mimic Zone 4.....	208
Mimic Zone 5.....	208
Mimic Zone 6.....	208
Mimic Zone 7.....	208
Mimic Zone 8.....	208
Radio Control Output 1.....	207
Radio Control Output 1 - Not In AWAY Mode.....	207
Radio Control Output 2.....	207
Radio Control Output 2 - Not In AWAY Mode.....	208
Remote Control 1.....	207
Remote Control 2.....	207
Remote Control 3.....	207
Ring Detect.....	208
Sensor Watch Alarm.....	205
Silent Alarm.....	206
Sirens Running.....	206
Speaker Beeps.....	205
Strobe Operating.....	206
System Armed.....	202
System Disarmed.....	202
Telephone Line Fail.....	204
Zone Not Sealed.....	208
Zone Not Sealed After Exit Time.....	209
Output Polarity	
Normally Low, Going Open.....	212
Normally Low, Latching Open.....	212
Normally Low, One Shot Open.....	212
Normally Low, One Shot Open With Alarm.....	212
Normally Low, One Shot Open With Reset.....	212
Normally Low, One Shot Open With Retrigger.....	212
Normally Low, Pulsing Open.....	212
Normally Open, Going Low.....	211
Normally Open, Latching Low.....	212
Normally Open, One Shot Low.....	211
Normally Open, One Shot Low With Alarm.....	212
Normally Open, One Shot Low With Reset.....	211
Normally Open, One Shot Low With Retrigger.....	211

Normally Open, Pulsing Low 211
 Output Not Used 211
 Outputs 200
 One Shot Polarities 214
 Polarity 211
 Pulsing Polarities 213
 Redirecting Output To Codepad Buzzer..... 201
 Timing 213
 Turning On/Off..... 87

P

Panic 260
 Panic Alarm 47
 PARTIAL Indicator 36, 237
 Partitioning
 Area Addressable Codepad Operations 240
 Codepad Operations..... 240
 Master Partitioned Codepad Operations 240
 Master Partitioned LED Codepad..... 236
 Programming 241
 Setting Up Area 1 Codepad 246
 Setting Up Area 2 Codepad 246
 Setting Up Master Partitioned Codepad 246
 User Code Allocations 245
 Zone Allocations..... 243
 Partitioning Options 1
 Display AUX Indicator When Using Telephone Line
 242
 First To Open/Last To Close Reporting..... 241
 Main Codepad To Display Data Only For Area 1 .. 241
 Resetting Of Sirens From Either Area 242
 Partitioning Options 2
 Enable "User Code + 0 + AWAY" To Arm/Disarm
 Both Areas 242
 Lock Area 1 To Receiver 1 & Lock Area 2 To
 Receiver 2 242
 Phone Controller..... 255, 260
 Plug Pack 256
 Point ID Codes..... 131
 Power Up Disarmed..... 230
 Primary Telephone Number For Receiver 1 139
 Primary Telephone Number For Receiver 2 142
 Programming 102
 Automatic Stepping Of Locations 115
 Codepad Indicators 103
 Entry/Exit Timers 216
 Installer's Programming Commands..... 107
 Option Bits..... 107, 152, 226
 Telephone Numbers..... 138
 Via Hand Held Programmer 105
 Via Programming Key 106
 Via Remote Codepad 103
 Programming Key..... 106, 254
 Copy From Programming Key To Panel 112
 Copy Panel Memory To Programming Key 111
 Erase 113
 Test 109
 Programming Sheets
 Solution 404..... 275
 Solution 406..... 285
 Solution 408..... 295
 PS100 Power Supply Module 255

Q

Quick Start 22

R

Radio Input Options 234
 Latching Keypress Input 234
 Momentary Keypress Input..... 234
 Radio Receiver 234
 Radio Key/Keypress Interface 230, 256
 Radio User Codes
 Transmitter Operations..... 56
 Receiver 1
 Handshake Tone..... 140
 Primary Telephone Number 139
 Secondary Telephone Number 139
 Subscriber ID Number 141
 Transmission Format..... 141
 Receiver 2
 Handshake Tone 143
 Primary Telephone Number 142
 Secondary Telephone Number 142
 Subscriber ID Number 144
 Transmission Format..... 144
 Relay Output 200
 Remote Arming Via Telephone 100, 153
 Remote Radio Transmitter Operations..... 56
 Add or Changing Transmitter Codes..... 58, 79
 Deleting Transmitter Codes 59, 80
 Horn Speaker Beeps 57
 Strobe Indications..... 57
 Remote Radio User Codes
 Adding Or Changing 58, 79
 Deleting..... 59, 80
 Reporting Format
 4 + 2 Reporting Format 133
 Basic Pager..... 134
 Contact ID Format..... 130
 Domestic Dialling 126
 Reset Control Panel Back To Factory Default 110
 RF
 Device Mapping (1 - 8) 250
 Device Mapping (9 - 16) 250
 Device Signal Strength (1 - 8)..... 251
 Dialler Reporting Options 188
 Jamming Monitoring 250
 Low Battery..... 187
 Receiver Trouble Report 188
 Receiver Trouble Restore Report 188
 Sound Siren On RF Receiver Fail 250
 Sound Siren On RF Receiver Tamper/Jamming 250
 Supervision Time 187
 Unseal Zone That Fails Supervision 250
 RF Low Battery 53
 RF Receiver Fail 53
 RF Transmitter Operations..... 56
 RF Zones
 Add..... 63
 Delete 64
 Ring Burst Time 150
 Ring Count 148
 S
 Satellite Siren 254, 259

Satellite Siren Service Mode	72	Internal Crystal To Keep Time	230
Sealed	260	System Status	
Secondary Telephone Number For Receiver 1	139	AC Mains Fail Report	193
Secondary Telephone Number For Receiver 2	142	AC Mains Fail Restore Report	193
Sensor Watch	54, 176, 260	Access Denied	195
Reports	186	Fuse Fail Report	192
Time	218	Fuse Fail Restore Report	192
Silent Alarm	176, 260	Low Battery Report	194
Siren & Strobe In STAY Mode	233	Low Battery Restore Report	194
Siren Run Time	219	Reporting Options	196
Siren Sound Rate	219	System Time	222
Smart Watch	227	T	
Software Version Number	273	Tamper Fail	54
Solution Codepad Mimic Board	256	Telco Arming Sequence	68, 146
<i>Specifications</i>	271, 273	Telco Disarming Sequence	147
STAY Indicator	29, 32	Telecom Connection Diagrams	265
STAY Indicator To Display Day Alarm Status	231	Telephone Anti-Jamming	268
STAY Mode 1	261	Telephone Arming	100, 153
Arming	42, 93	Telephone Line Fail	53
Disarming	44	Lockout Alarm	155
STAY Mode 2	261	Telephone Line Fault Options	149
Arming	45, 94	Telephone Monitor Mode	73
Disarming	46	Telephone Numbers	
Setting Zones	71, 86	Changing Domestic Phone Numbers	66
Strobe		Terminal Definitions and Descriptions	258
Indications For Radio Arm/Disarm	227	Test Reports	97
Strobe Output	200	After Siren Reset	231
Strobe Test	94	Dialler Options	197
Subscriber ID Number For Receiver 1	141	Only When Armed	231, 269
Subscriber ID Number For Receiver 2	144	Repeat Interval	197
Supervision Time	187	Reporting Time	197
Swinger Shutdown Count		Set First Test Report	65
For Dialler	182	TF008 Plug Pack	256
For Siren	181	Transmission Format For Receiver 1	141
System Date	223	Transmission Format For Receiver 2	144
System Disarmed Indicator	32	Transmitter Operations	56
System Operations	40	Trouble Reports	185
Arming In AWAY Mode	40	U	
Arming In STAY Mode 1	42	Unsealed	261
Arming In STAY Mode 2	45	User Code Function	
Disarming From AWAY Mode	41	Arm/Disarm Both Areas At Same Time	92
Disarming From STAY Mode 1	44	User Codes	159, 261
Disarming From STAY Mode 2	46	Adding Or Changing	77, 79
System Options 1	227	Allocations When Partitioning	245
Assign Button 4 On Transmitter To Arm STAY Mode		Deleting	78, 80
1	227	Priority Level	161
EDM Smart Lockout	227	W	
Monitoring Of Horn Speaker	227	Walk Test Mode	74, 90
Strobe Indications For Radio Arm/Disarm	227	Warranty Statement	272
System Options 2	228	Wireless Zones	
Access Denied To Be Silent	228	Add	63
Codepad Fire To Be Silent	228	Delete	64
Codepad Medical To Be Silent	228	Wiring Diagram	262
Codepad Panic To Be Silent	228	Z	
System Options 3	229	Zone	
AC Fail In 1 Hour	229	Allocations	243
Handover Delay To Be Sequential	229	Defaults	24, 170
Ignore AC Mains Fail Indication	229	Dialler Options	169, 180
Zone Pulse Count Handover	229	EOL Resistor Value	166
System Options 4	230	Indicators	28, 31, 35, 236
Arm/Disarm Tracking On Power Up	230		
Enable Control Panel To Power Up Disarmed	230		
Enable Radio Key/Keypad Interface or Night Arm			
Station	230		

Isolating - Code To Isolate.....	50	Zone Restore Report	179
Isolating - Standard.....	49	Zone Reporting Information	
Isolating Allowed.....	179	Dialler Options	180
Operating Information	169	Zone Report Code	180
Options 1.....	169, 175	Zone Restore Code.....	186
Options 2.....	169	Zone Status	
Programming	169	Bypass Reports.....	185
Pulse Count.....	169, 173	Reporting Options	186
Pulse Count Handover	173, 229	Sensor Watch Reports.....	186
Pulse Count Time	169, 174	Tamper Reports.....	184
Report Code.....	169	Trouble Reports.....	185
Reporting Information	169, 180	Walk Test Reports.....	184
Restore Code.....	186	Zone Types	
Restore Report	179	24 Hour Burglary Zone	172
Status Mode	108	24 Hour Fire Zone	172
Trouble	185	24 Hour Hold-Up Zone	172
Types	25, 169, 171	24 Hour Medical	172
Zone Bypass	185	24 Hour Panic Zone	172
Zone Options 1		24 Hour Tamper	172
Delay Alarm Reporting.....	175	Chime Zone	173
Lockout Siren & Dialler	175	Delay-1 Zone.....	171
Sensor Watch.....	176	Delay-2 Zone.....	171
Silent Alarm.....	176	Handover Zone.....	171
Zone Options 2		Instant Zone.....	171
Forced Arming.....	179	Keyswitch Zone	172
Isolate In STAY Mode 1.....	179	Zone Not Used	173
Zone Isolation Allowed	179	Zones.....	261



Electronics Design & Manufacturing Pty Limited

25 Huntingwood Drive
Huntingwood NSW 2148
Australia

A.C.N. 002 907 271

Phone: +612 9672 1777
Facsimile: +612 9672 1717
email: edm@edm.com.au
